

***ECE145a / 218a***  
***Resistive Feedback Amplifiers***

***Mark Rodwell***

***University of California, Santa Barbara***

rodwell@ece.ucsb.edu 805-893-3244, 805-893-3262 fax

# Resistive Feedback For Line Termination

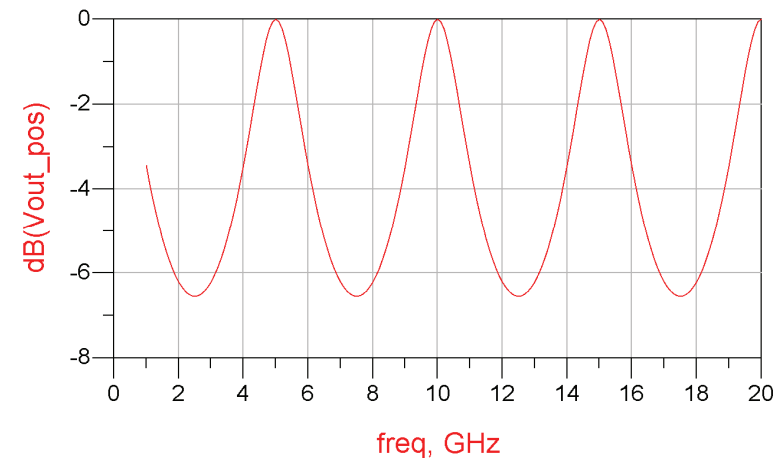
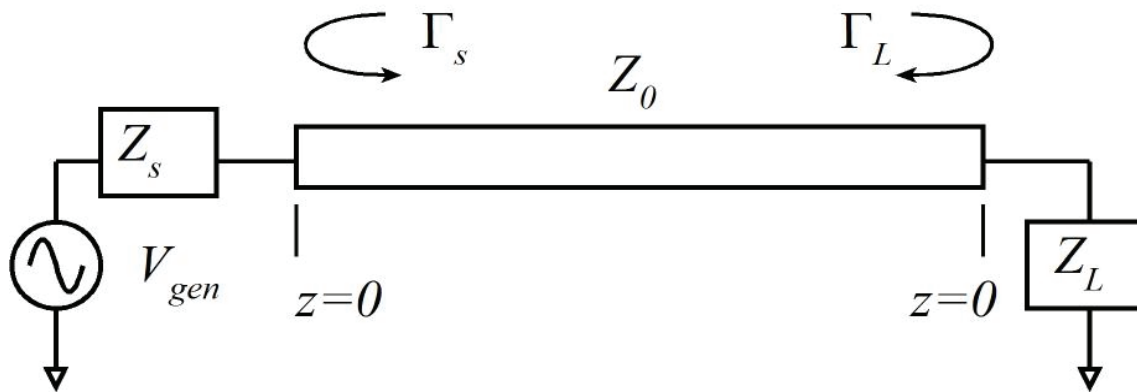

Recall : there are 2 different reasons for impedance - matching

- 1) Maximum power transfer
- 2) Avoiding gain ripple from standing waves on lines.

In resistive feedback amplifiers, feedback provides  $Z_{in} = Z_{out} = Z_o$  in order to eliminate line reflections.

These are \* not \* designed for maximum power transfer, hence we do not obtain the transistor maximum gain.

# World's Simplest Amplifier

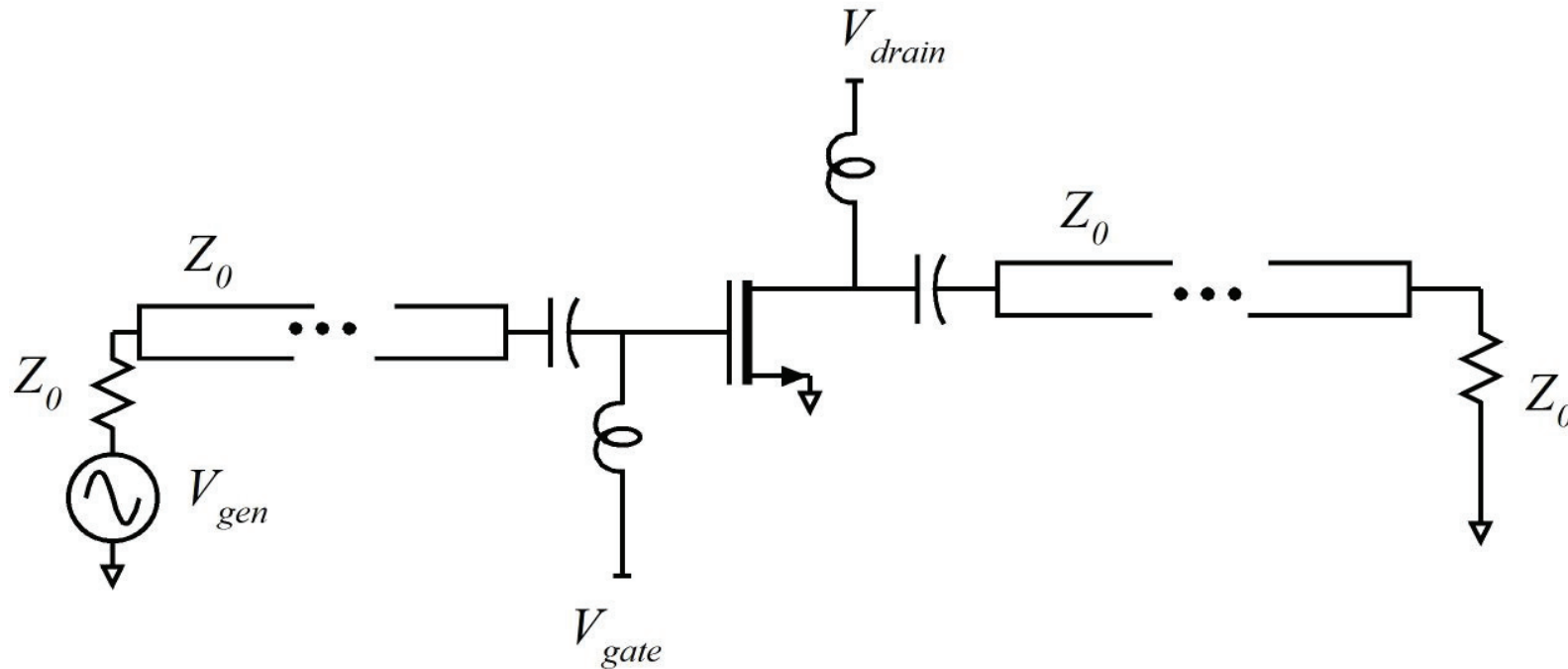

Amplifier consists of transistor and bias tees,  
connected to input and output transmission - lines.

Transmission - lines are external to amplifier;  
reference planes are at line ends.

# Analysis

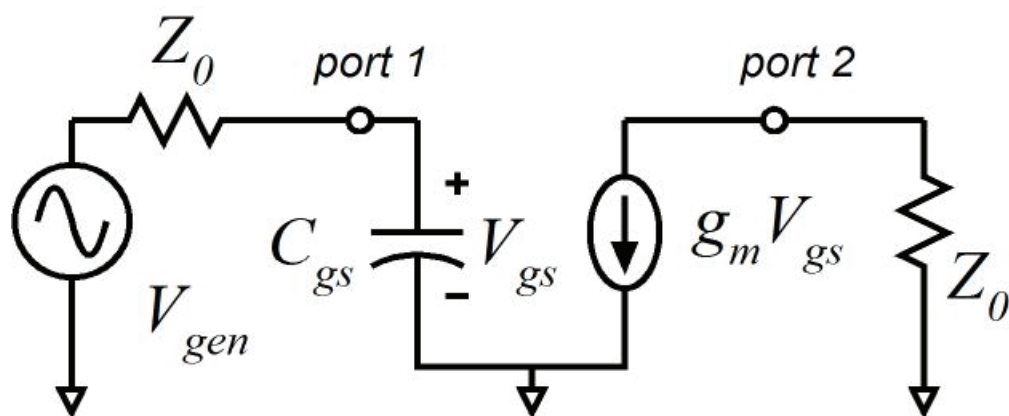
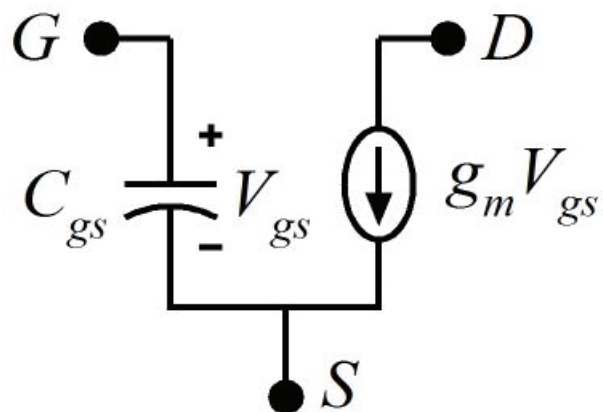
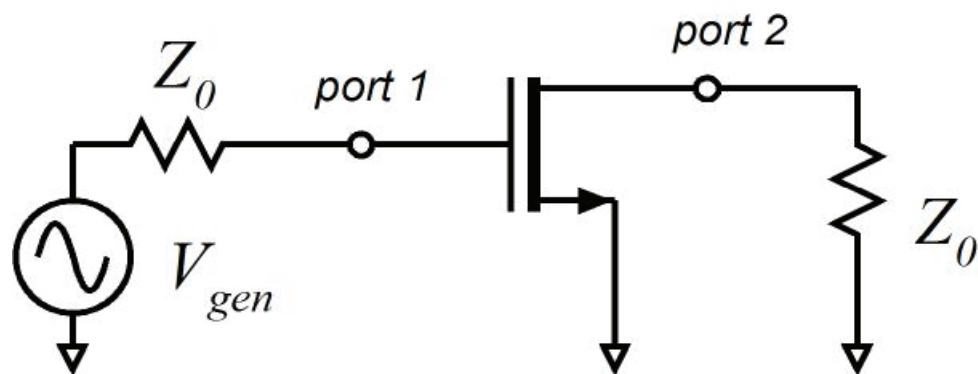

To find S - parameters,  
we compute gains and impedances  
with  $Z_{gen} = Z_{load} = Z_0$ .

Take the DC bias elements as implicit.

Use - for now - a highly simplified  
device model.

Circuit to analyze

# Analysis

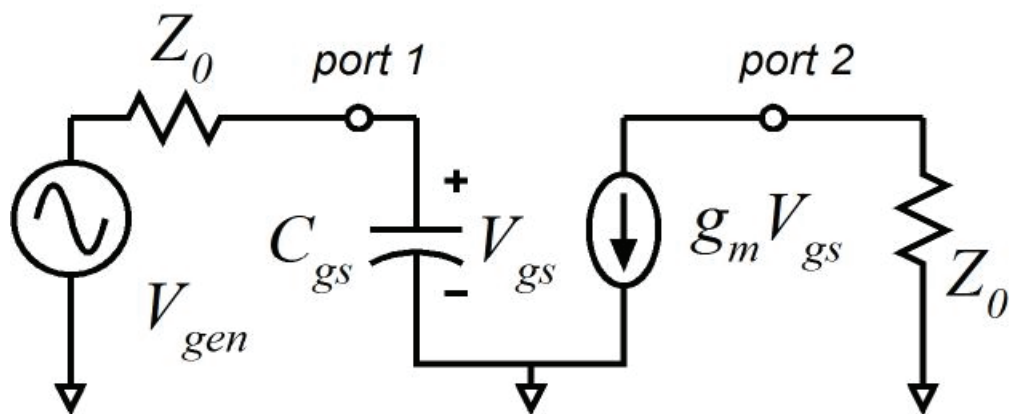

By inspection :

$$S_{21} = 2 \frac{V_{out}}{V_{gen}} \Big|_{Z_{gen}=Z_L=Z_0} = \frac{-2g_m Z_0}{1 + j\omega Z_0 C_{gs}}$$

$$Z_{in} = 1 / j\omega C_{gs} \rightarrow S_{11} = \frac{Z_{in} / Z_o - 1}{Z_{in} / Z_o + 1}$$

$$R_{out} = \infty \rightarrow S_{22} = \frac{Z_{out} / Z_o - 1}{Z_{out} / Z_o + 1}$$

What is wrong with this amplifier ?

Though gain is lower than  $G_{max}$  (no matching), it may meet our needs !

More serious problem : large  $S_{11}$ ,  $S_{22}$   $\rightarrow$  standing waves  $\rightarrow$  gain ripple.

# Standing Waves

Reflections at both line ends will cause gain/phase variations of the form:

$$\frac{1}{1 - e^{-2j\beta l} \Gamma_S \Gamma_L},$$

hence gain will vary with both cable length and with frequency.

We need to fix this.

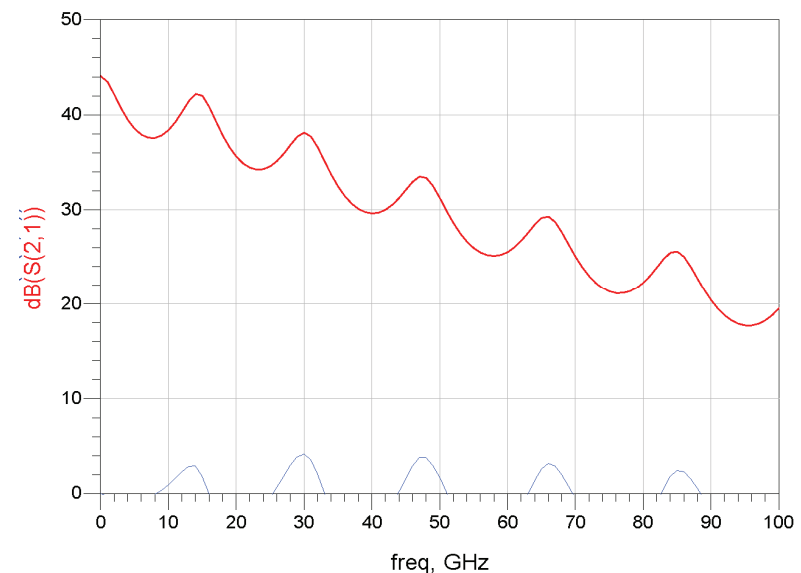
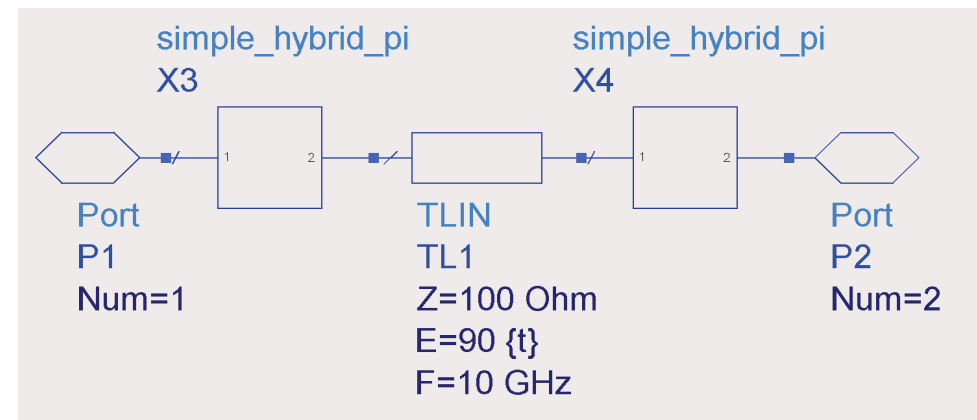
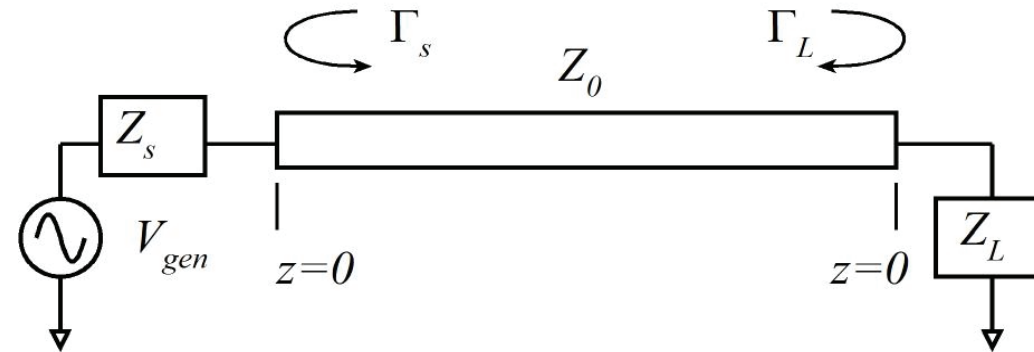

# Eliminating Standing Waves

So, while we can directly match two stages directly, thus...

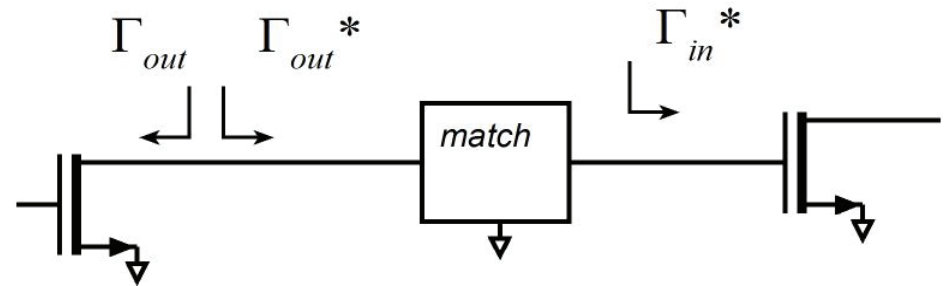

...this is only acceptable if line lengths are short and the connection permanent.

If lines are long, or the components modular, so that connections can be changed, we must match each device to  $Z_0$ .

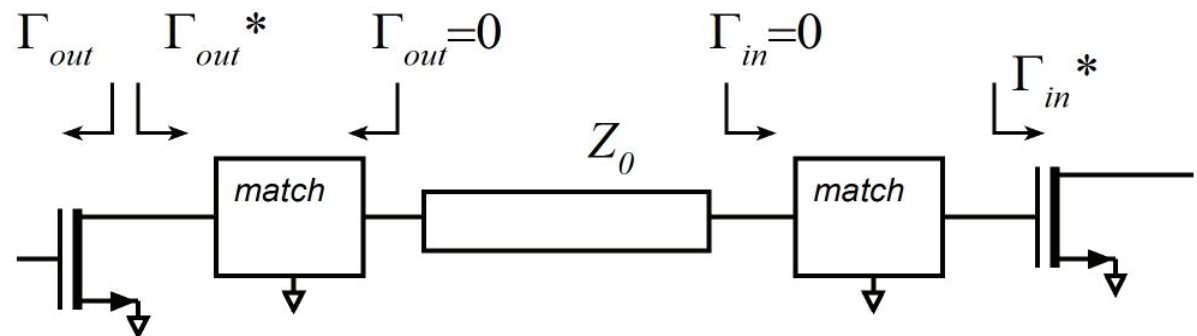

# Types of Impedance Matches

---

Reactive Impedance Matching (lossless):

Reflection coefficients  $\rightarrow 0$ .

No power reflected.

No signal power absorbed in matching networks.

$\rightarrow$  Circuit Gain = device maximum available gain (maybe)

Resistive Impedance Matching (lossy):

Reflection coefficients  $\rightarrow 0$ .

No power reflected.

Signal power absorbed in matching networks.

$\rightarrow$  Circuit Gain less than device maximum available gain



# World's Second Simplest Amplifier

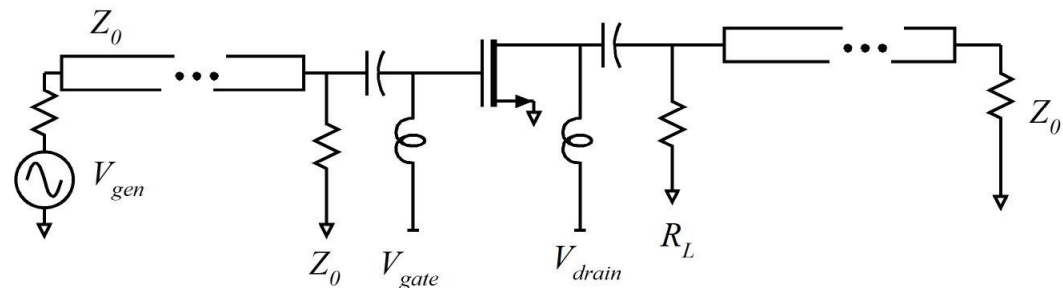

In the absence of transistor parasitics,  
lines are now terminated in  $Z_0$ .

Reflections are now (nearly) eliminated.

Power gain is wasted :  
signal dissipation in terminations

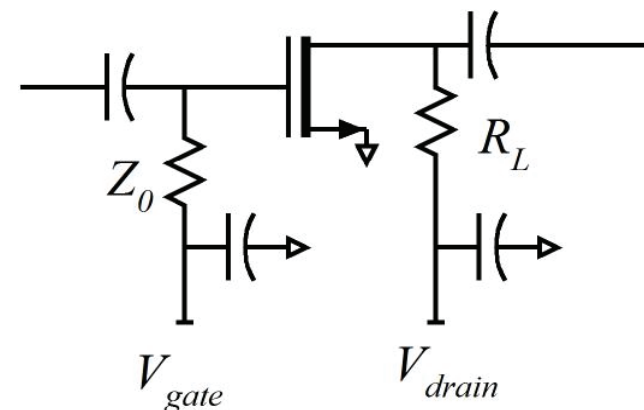

# Analysis

Circuit (bias implicit)

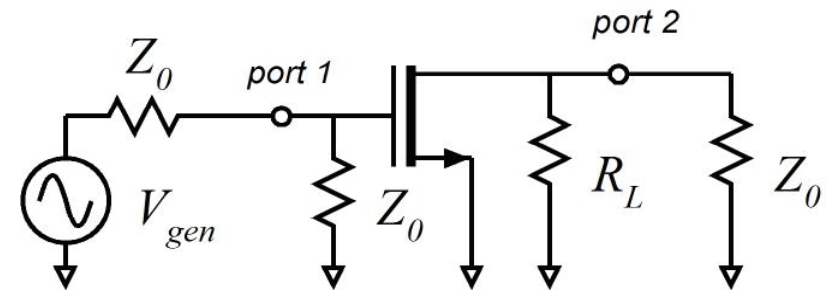

(over) - simplified device model

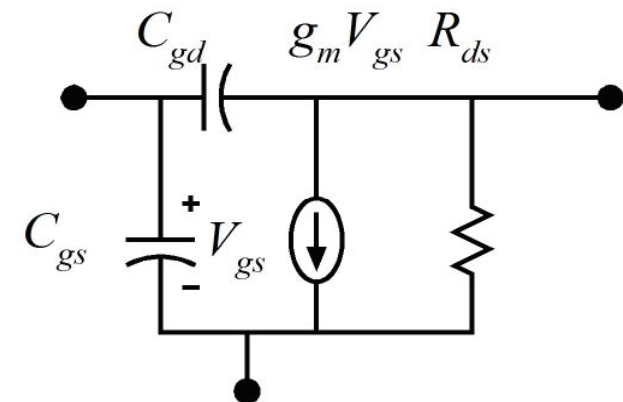

Circuit Model

We will pick  $R_{ds} \parallel R_L = Z_0$

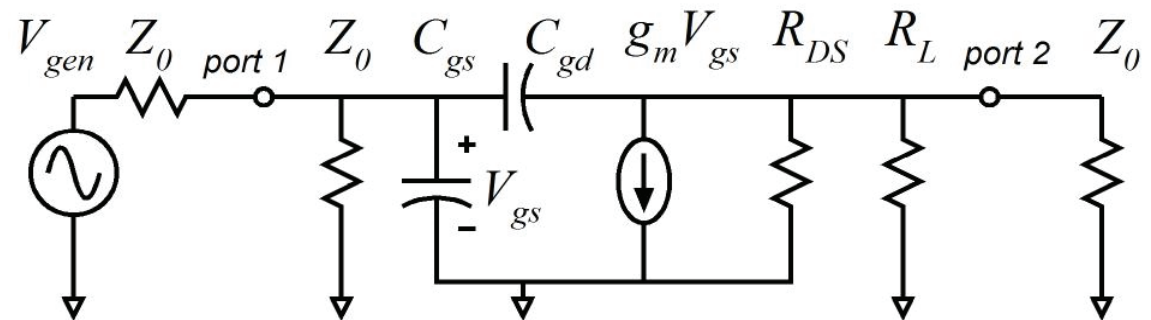

# Analysis

As always:

$$S_{21} = 2 \frac{V_{out}}{V_{gen}} \Big|_{Z_{gen}=Z_L=Z_0}$$

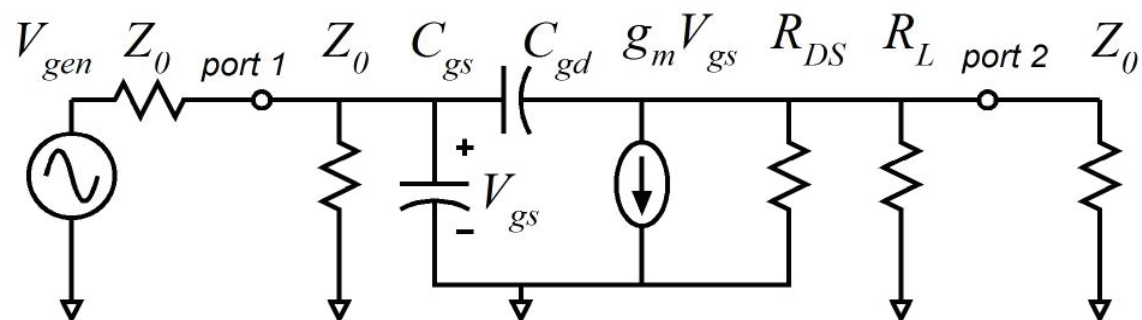

By nodal analysis or MOTC:

$$S_{21} = -(g_m Z_0 / 2) \frac{1 + b_1 s}{1 + a_1 s + a_2 s^2}$$

where  $a_1 = C_{gs} (Z_0 / 2) + C_{gd} [(Z_0 / 2)(1 + g_m Z_0 / 2) + (Z_0 / 2)]$

the terms  $a_2$  and  $b_1$  are relevant only at very high frequencies.

The Miller effect term should be obvious.

# Analysis

$$S_{21} \cong -(g_m Z_0 / 2) \frac{1}{1 + j\omega a_1} \text{ where } a_1 = C_{gs} (Z_0 / 2) + C_{gd} [(Z_0 / 2)(1 + g_m Z_0 / 2) + (Z_0 / 2)]$$

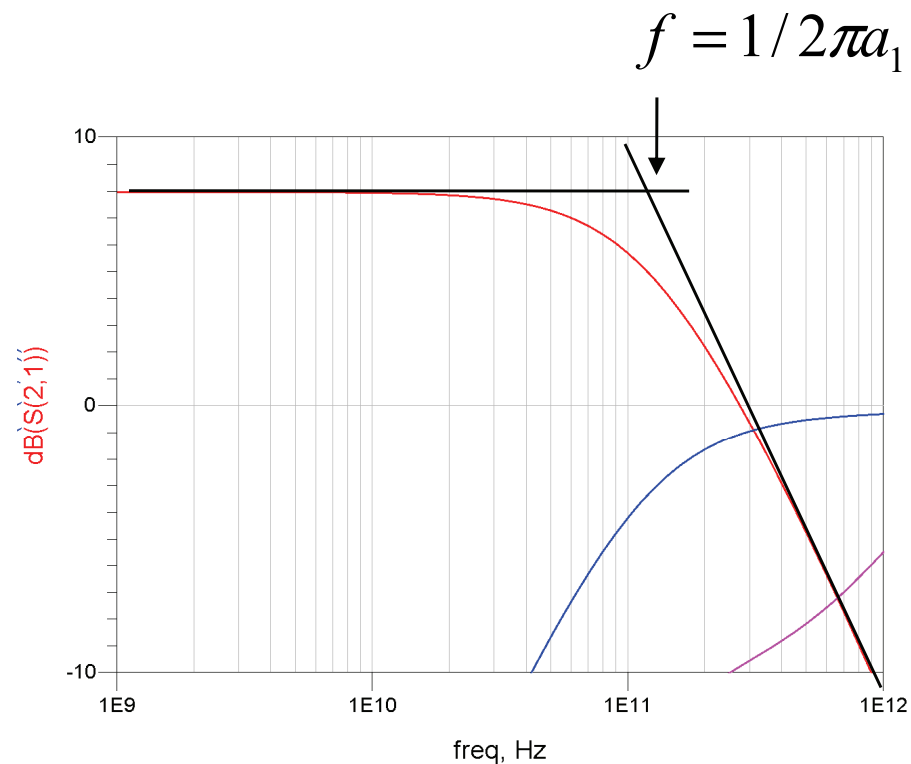
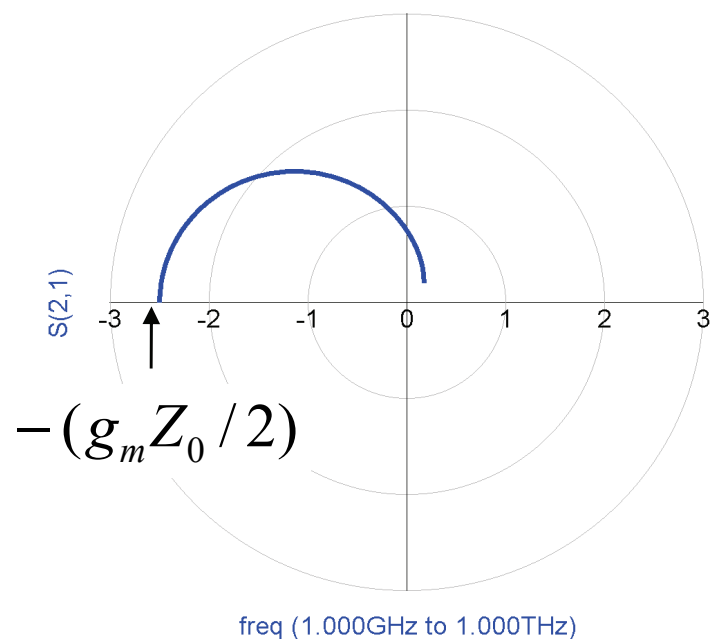

Note the standard Bode Plot behavior with -20 dB/decade slope and 3 dB corner.

Note that the  $S_{21}$  trajectory is a semicircle in the complex plane.

# Input Impedance

Using the Miller Approximation :

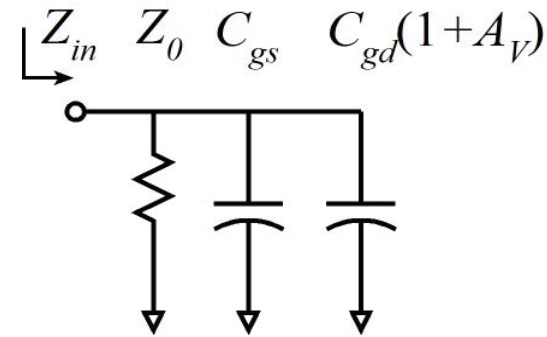

Note that this (almost) follows a constant - G circle on the Smith chart.

Note the single - pole behavior of  $S_{11}$ .

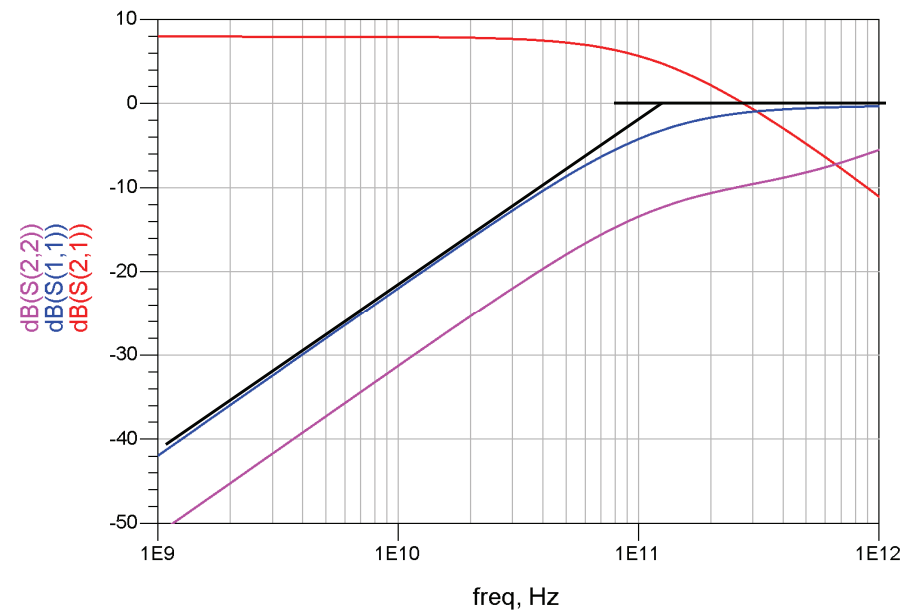
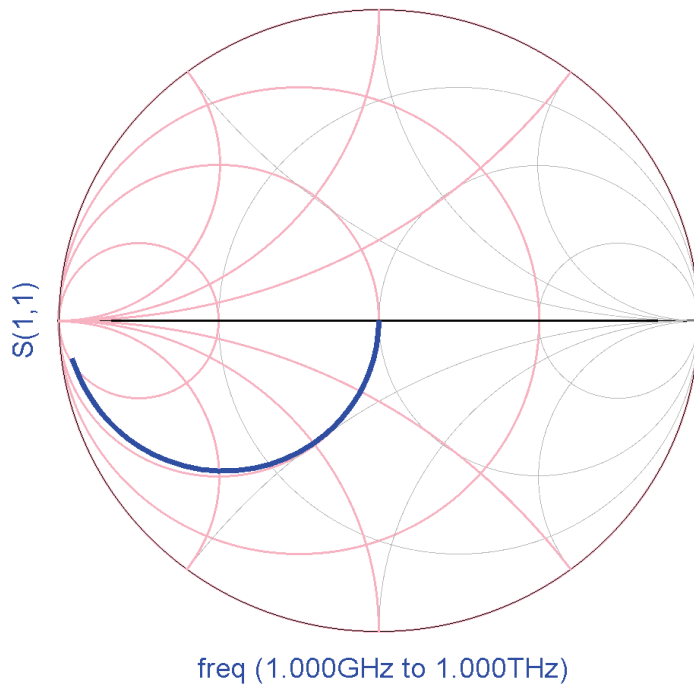

# Gain-Bandwidth Product

---

$$\|S_{21,baseband}\| \cong (g_m Z_0 / 2) \text{ and } 1/2\pi f_{high} \cong C_{gs} (Z_0 / 2) \text{ if } C_{gd} \rightarrow 0$$

$$\text{So, gain - BW product} = \|S_{21,baseband}\| f_{high} = g_m / 2\pi C_{gs} = f_\tau$$

A rough calculation only;

poorer bandwidth when other device parasitics are considered.

# Simple Resistive-Terminated Amplifier: General Form

This stage generalizes  
to use with any  $g_m$  block.

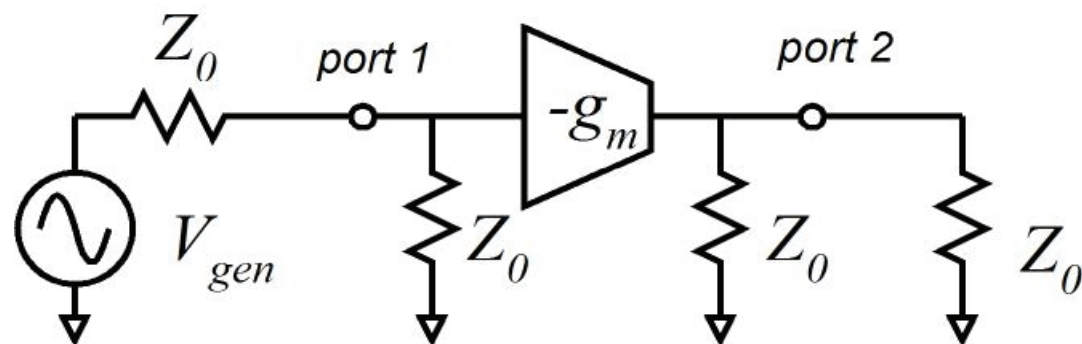

Recall : extrinsic transconductance for  
a transistor with emitter/source degeneration

$R_x$  is

$$g_{m,extrinsic} = (1/g_{m,transistor} + R_x)^{-1}$$

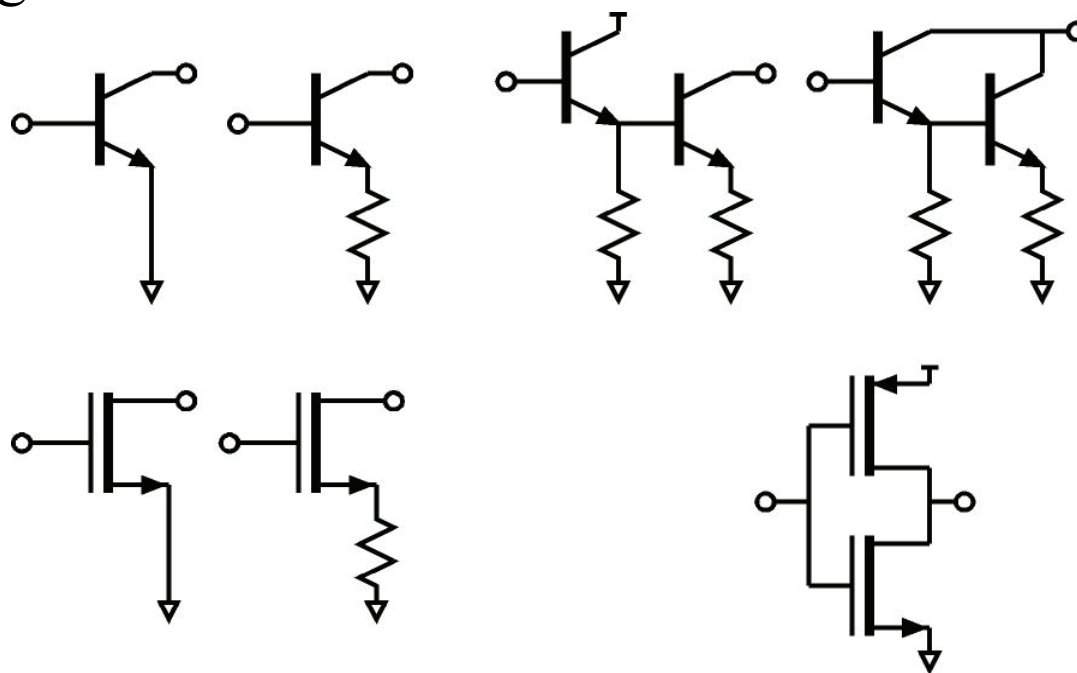

# Broadband Feedback Amplifier

Resistive Feedback used  
to provide input and output  
impedances of  $Z_0$

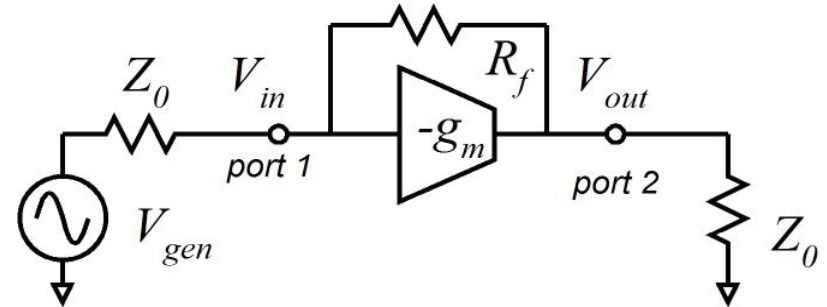

We want:  $V_{out} / V_{in} = -A_v$  and  $Z_{in} = Z_0$

We must find  $g_m, R_f$  necessary to obtain this.

If we are lucky, we will also get  $Z_{out} = Z_0$ .



# Finding $R_f$ :

Input current :  $I_{in} = V_{in} / Z_{in} = V_{in} / Z_0$

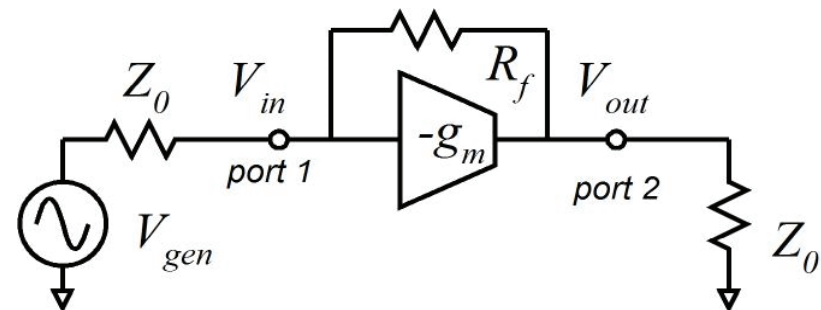

Current in  $R_f$  :

$$I_{R_f} = (V_{in} - V_{out}) / R_f = (V_{in} + A_v V_{in}) / R_f = V_{in} (1 + A_v) / R_f$$

But :  $I_{R_f} = I_{in}$

$$V_{in} / Z_0 = V_{in} (1 + A_v) / R_f$$

$$\rightarrow R_f = Z_0 (1 + A_v)$$

# Finding $g_m$ :

Current in  $R_f$ :

$$I_{R_f} = V_{in} / R_{in} = V_{in} / Z_0$$

Current in load  $R_f$ :

$$I_{out} = V_{out} / Z_0 = -V_{in} A_v / Z_0$$

$g_m$  block output current:

$$I_{g_m} = -g_m V_{in} = I_{out} - I_{R_f} = -V_{in} A_v / Z_0 - V_{in} / Z_0 = -V_{in} (1 + A_v) / Z_0$$

$$\rightarrow g_m = (1 + A_v) / Z_0$$

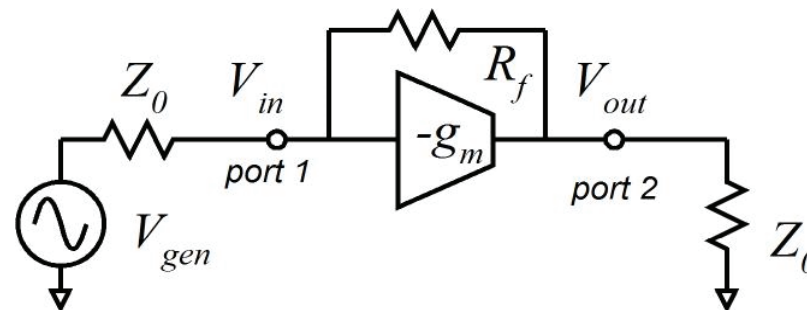

# Finding $Z_{out}$ (harder):

$$V_{in} = V_{test} Z_0 / (Z_0 + R_f)$$

$$\begin{aligned} I_{test} &= \text{current in } R_f + \text{current in } g_m \\ &= V_{in} / Z_0 - g_m V_{in} \end{aligned}$$

$$G_{out} = \frac{1}{R_{out}} = \frac{I_{test}}{V_{test}} = \frac{Z_0}{Z_0 + R_f} \left( \frac{1}{Z_0} - g_m \right)$$

$$G_{out} = \frac{Z_0}{Z_0 + Z_0(1 + A_v)} \left( \frac{1}{Z_0} + \frac{1 + A_v}{Z_0} \right)$$

$$G_{out} = \frac{1}{2 + A_v} \cdot \frac{1}{Z_0} (2 + A_v)$$

$$G_{out} = \frac{1}{Z_0}!!!!$$

Output is impedance - matched

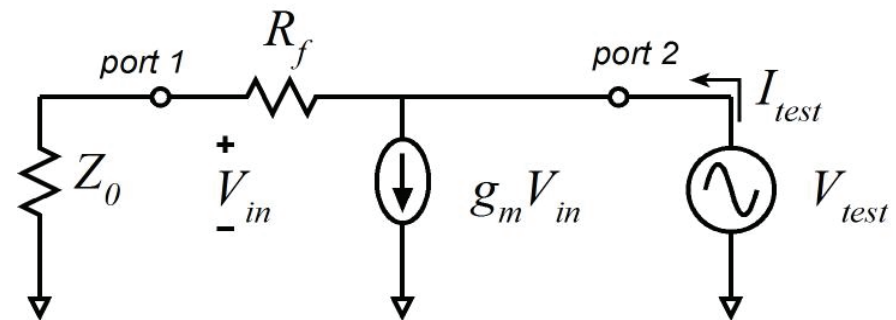

# Broadband Feedback Amplifier: Summary

We want:  $V_{out} / V_{in} = -A_v$  ,  $Z_{in} = Z_0 = Z_{out}$

This is obtained by setting:

$$g_m = \frac{1 + A_v}{Z_0} \text{ and}$$

$$R_f = (1 + A_v)Z_0$$

Though, note that  $Z_{in} = Z_0$  only if  $Z_L = Z_0$

and  $Z_{out} = Z_0$  only if  $Z_{gen} = Z_0$

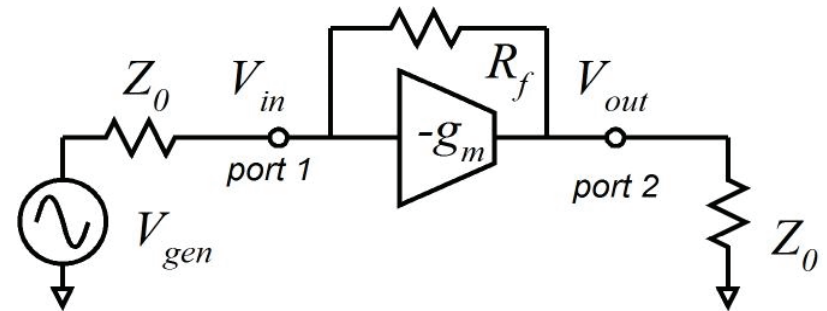

# Broadband Feedback Amplifier: Why do it ?

Why do this...

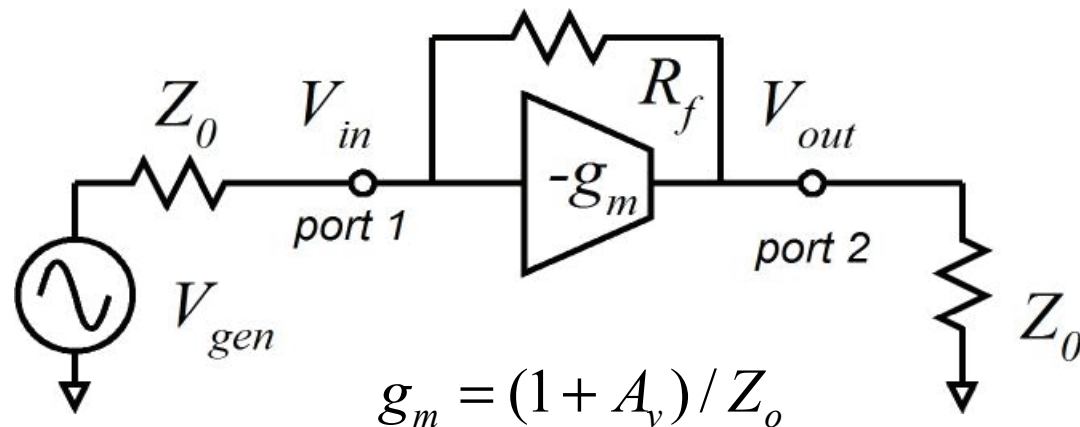

...instead of this ?

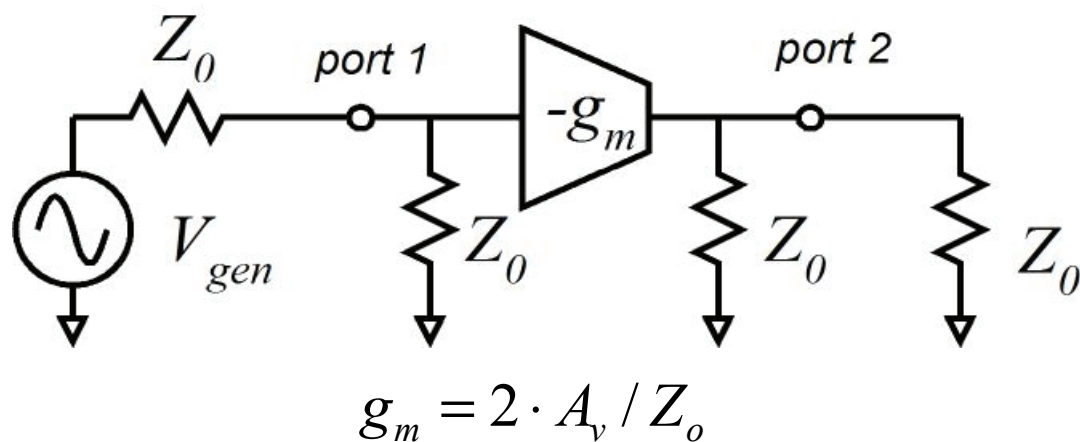

Answer : more bandwidth, less noise (noise for a later discussion).

# Capacitance as the Price for Transconductance

Highly simplified

device model:

$$f_{\tau} = g_m / 2\pi C_{in}$$

$$\rightarrow C_{in} = g_m / 2\pi f_{\tau}$$

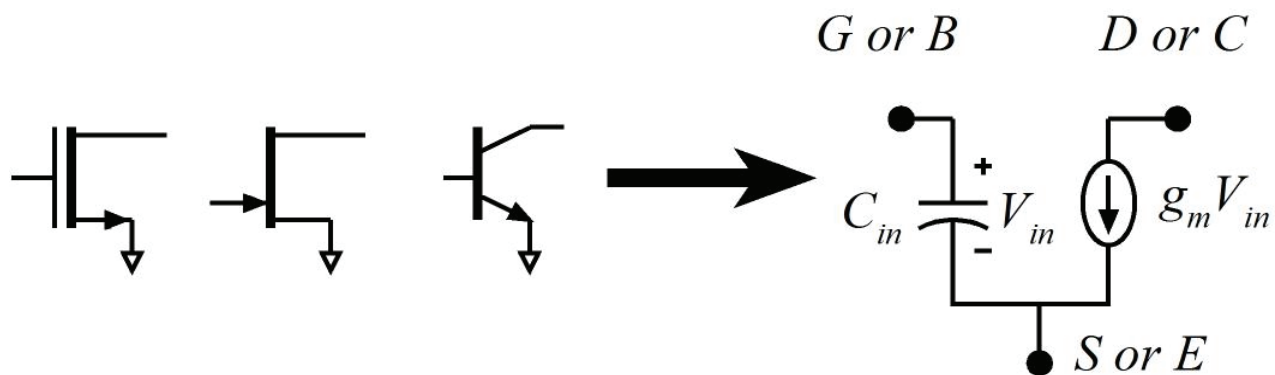

The device input capacitance  $C_{in}$  is proportional its transconductance  $g_m$ .

The feedback amplifier requires less  $g_m \rightarrow$  less device  $C_{in}$ .

# Capacitance as the Price for Transconductance

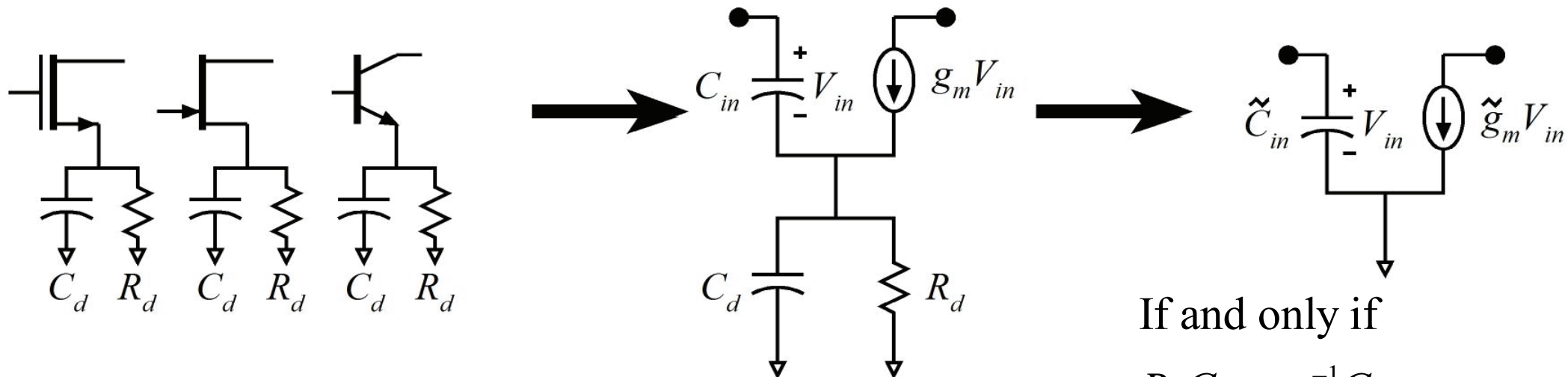

If and only if  
 $R_d C_d = g_m^{-1} C_{in}$

then

$$\tilde{C}_{in} = C_{in} / (1 + g_m R_d)$$

$$\tilde{g}_m = g_m / (1 + g_m R_d)$$

$$\rightarrow \tilde{C}_{in} = \tilde{g}_m / 2\pi f_\tau$$

Even with resistive degeneration,  
 input capacitance is proportional to transconductance.

# Broadband Feedback Amplifier: Bandwidth Analysis

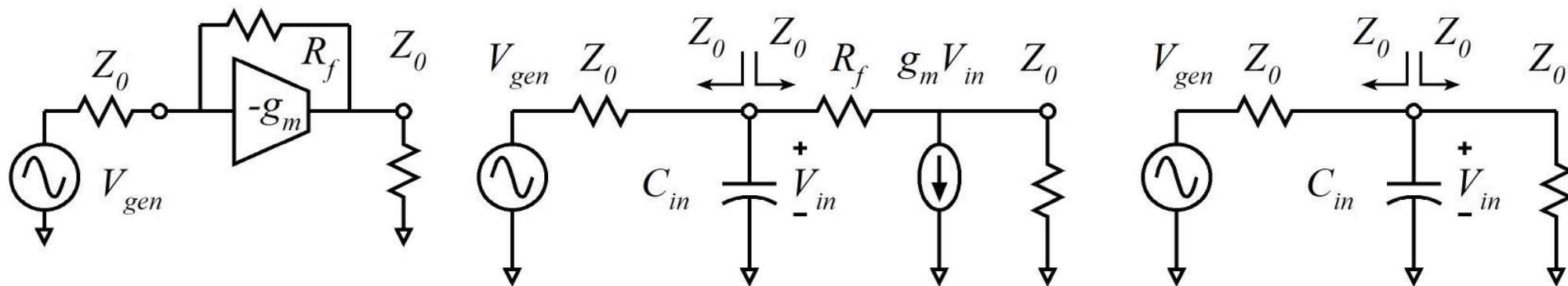

$$C_{in} = g_m / 2\pi f_\tau \text{ but } g_m = (1 + A_v) / Z_o \text{ so } C_{in} = (1 + A_v) / 2\pi f_\tau Z_o$$

$$\text{but } f_{3dB} = 1 / 2\pi a_1 \text{ where } a_1 = C_{in} (Z_o \parallel Z_o) = C_{in} Z_o / 2$$

$$\text{so } f_{3dB} = f_\tau \frac{2}{1 + A_v}$$

Less  $g_m$  required  $\rightarrow$  less  $C_{in}$   $\rightarrow$  more bandwidth



# Compare to Simple Resistive Amplifier

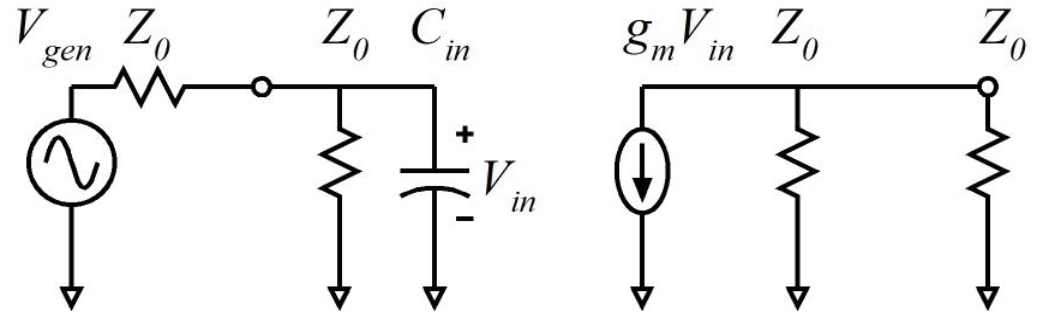
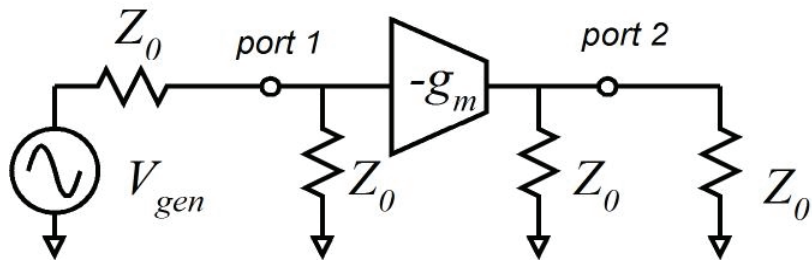

$$C_{in} = g_m / 2\pi f_\tau \text{ but } g_m = 2 \cdot A_v / Z_0 \text{ so } C_{in} = 2 \cdot A_v / 2\pi f_\tau Z_0$$

$$\text{but } f_{3dB} = 1 / 2\pi a_1 \text{ where } a_1 = C_{in} (Z_0 \parallel Z_0) = C_{in} Z_0 / 2$$

$$\text{so } f_{3dB} = \frac{f_\tau}{A_v}$$

More  $g_m$  required  $\rightarrow$  More  $C_{in}$   $\rightarrow$  less bandwidth

# Bandwidth Analysis with $C_{gd}$ or $C_{cb}$

Slightly better device model:  
include feedback capacitance

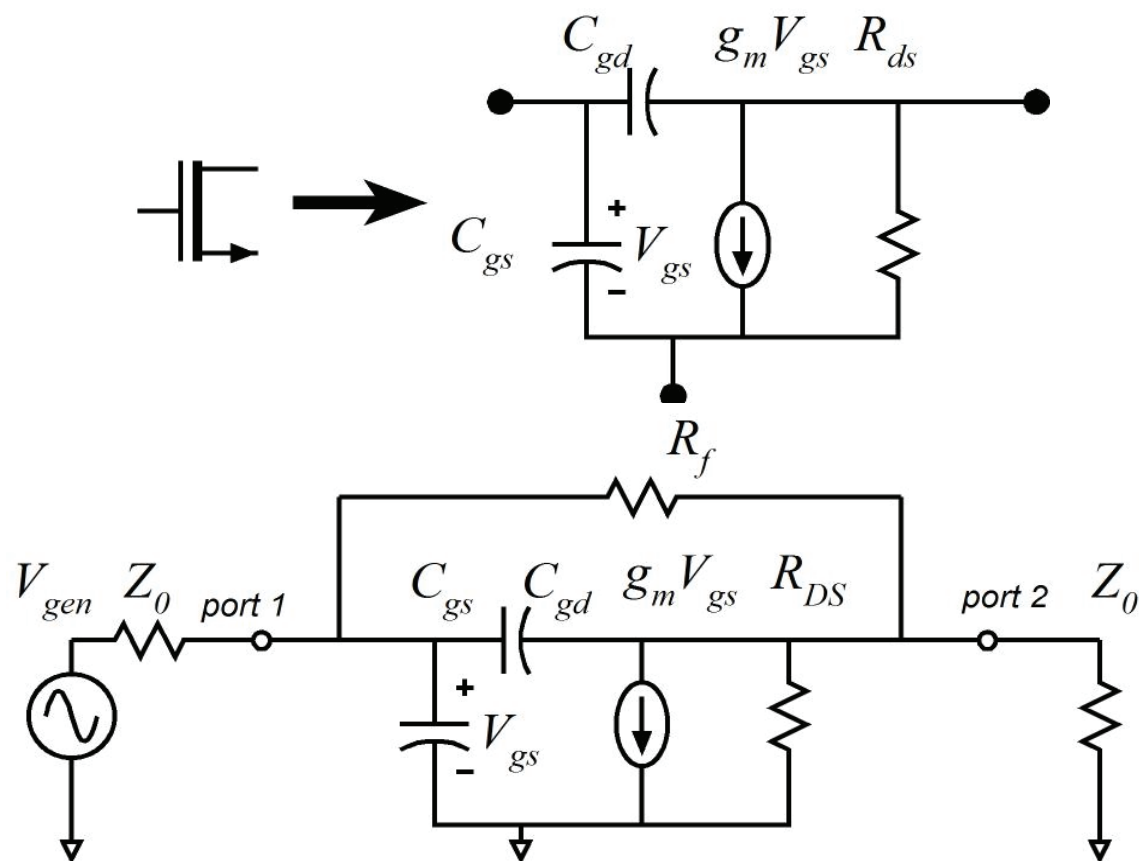

Straightforward to show by MOTC (analog notes)

$$\begin{aligned}
 a_1 &\cong C_{gs} (Z_0 / 2) + C_{gd} \left( R_f \parallel \{ Z_0 (1 + g_m Z_0) + Z_0 \} \right) \\
 &= C_{gs} (Z_0 / 2) + C_{gd} \left( \{ Z_0 (1 + A_v) \} \parallel \{ Z_0 (1 + 1 + A_v) + Z_0 \} \right) \\
 &= C_{gs} (Z_0 / 2) + C_{gd} Z_0 \frac{(1 + A_v)(3 + A_v)}{2(2 + A_v)}
 \end{aligned}$$