

A Green Internet

Rodney S. Tucker

ARC Special Research Centre for
Ultra-Broadband Information Networks (CUBIN)
University of Melbourne

r.tucker@ee.unimelb.edu.au



Energy Consumption and Data

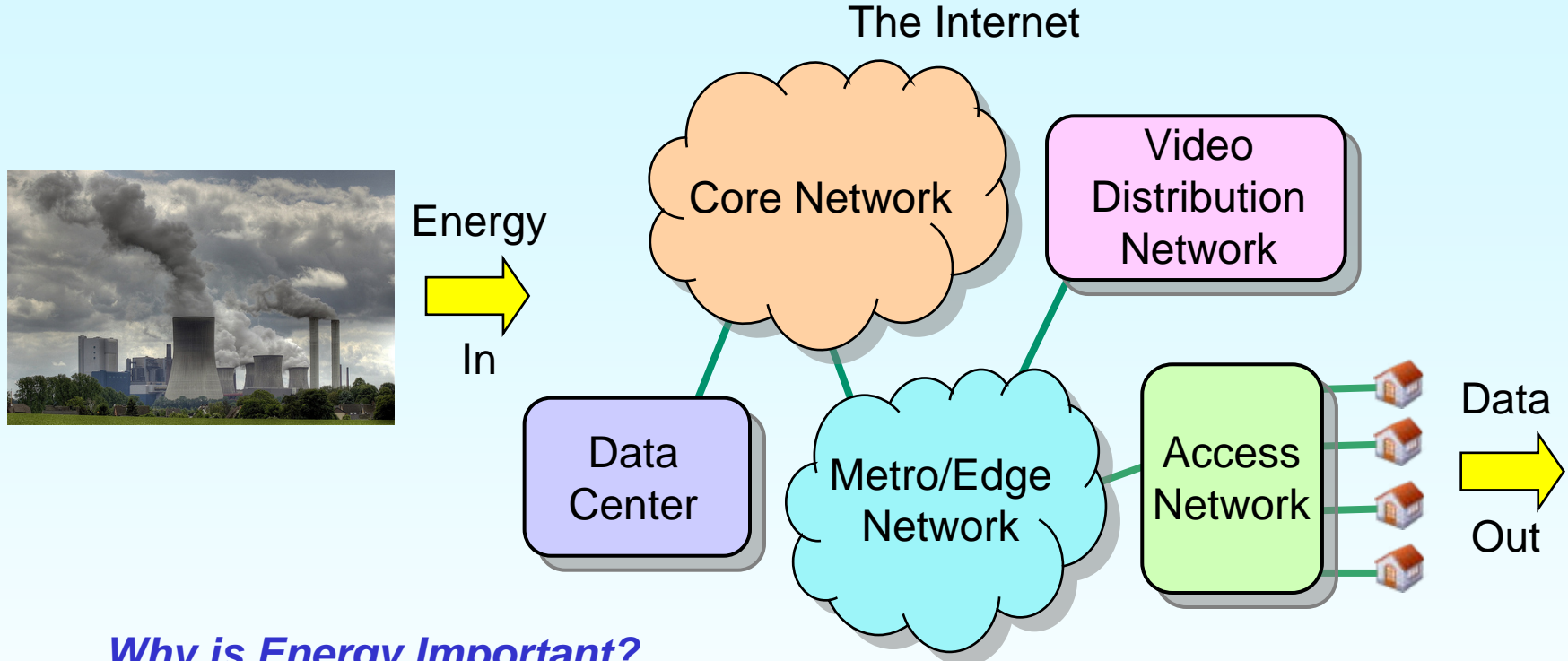

Why is Energy Important?

- OPEX
- Greenhouse Impact
- Energy-limited capacity bottlenecks (“hot spots”)
- Enabling energy efficiencies in other sectors

Putting Things into Context

Information and Communication Technologies (ICT)

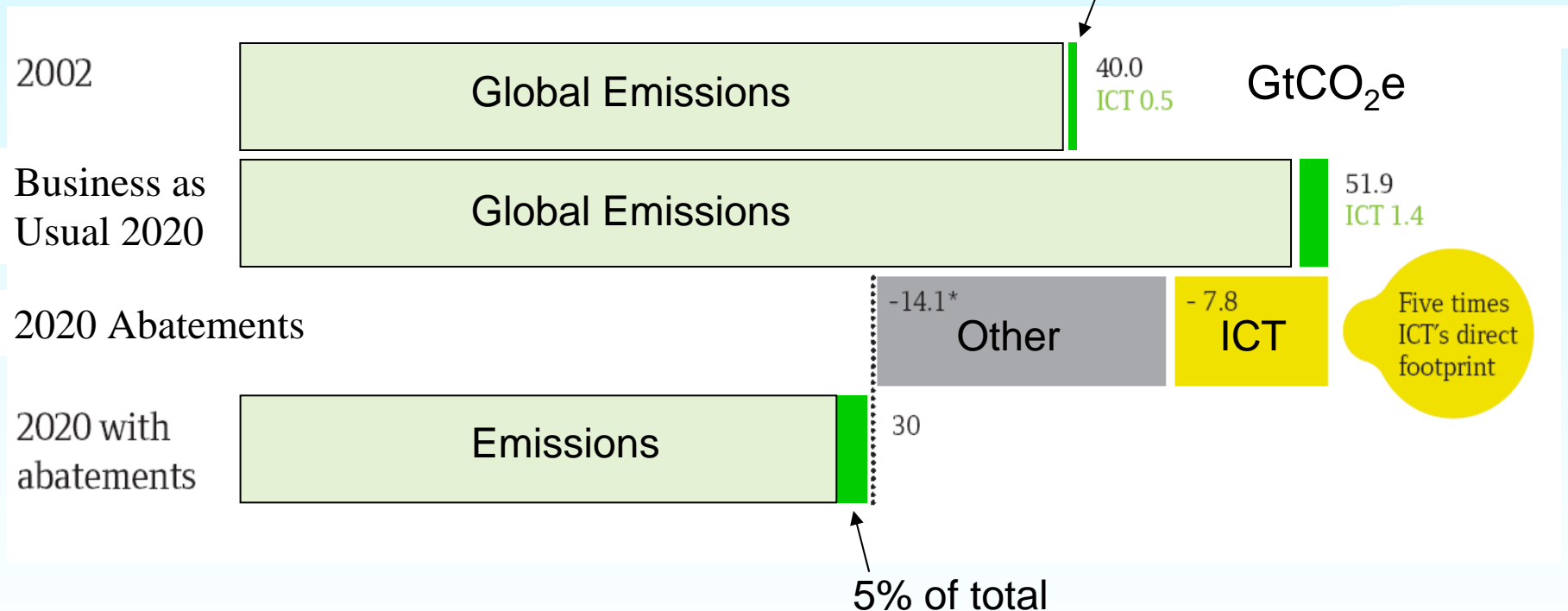

“SMART 2020: Enabling the low carbon economy in the information age,”
GeSI, 2008 www.gesi.org



Summary

- Estimating energy consumption of the Internet
- Where does the energy go
 - Core, metro, access network?
- What will happen as traffic grows over time?
- Saving energy through travel replacement
- Can photonic technologies help to build a Green Internet?

Caveat: “Making predictions is difficult – especially about the future.”



Network Energy Model

Tier 1 Network

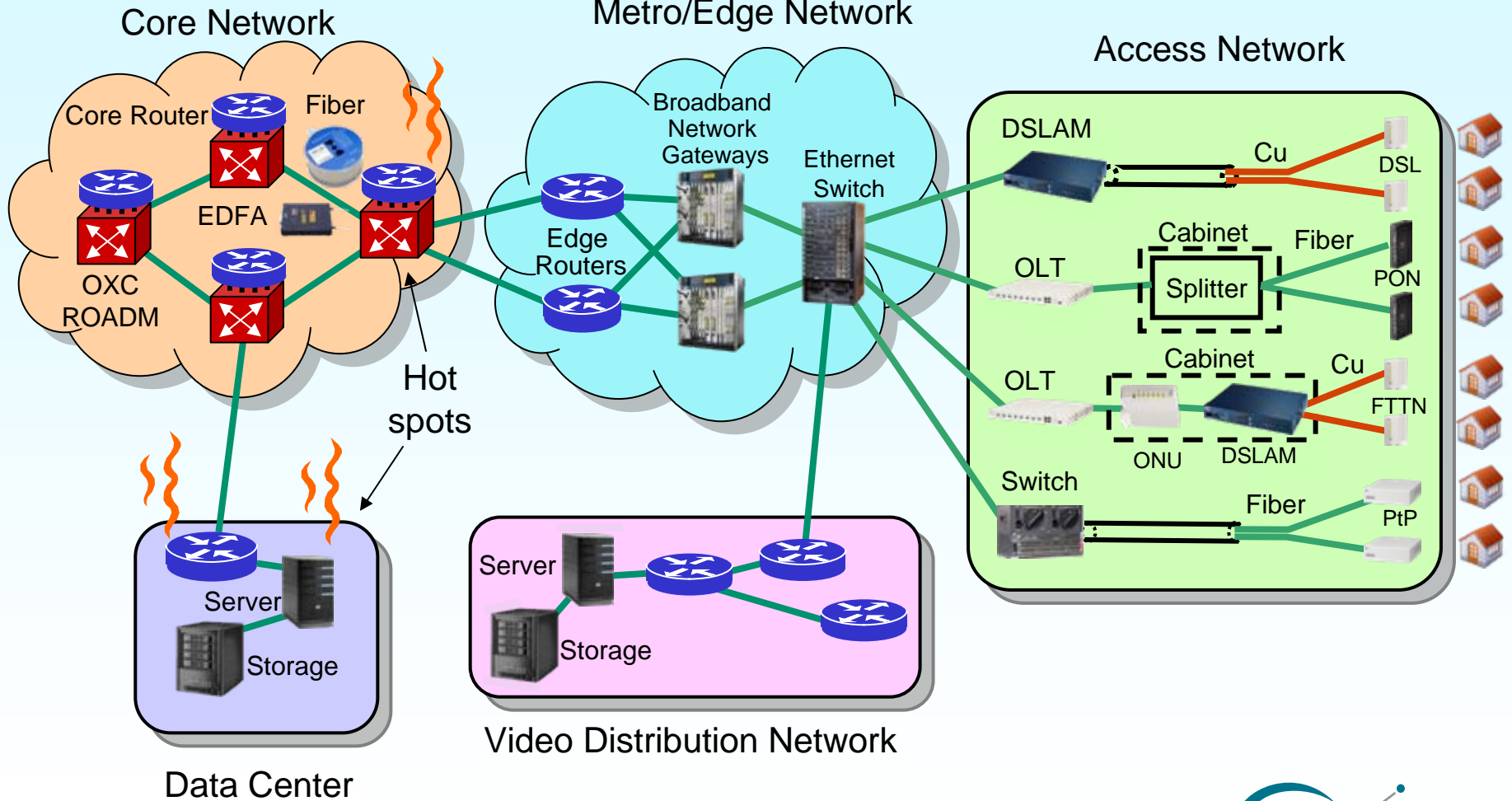

Estimating Energy Consumption

- Choose an access data rate (capacity per user)
- Carry out paper design of network
- Calculate the power consumed by the network *per user*
- Repeat for all access rates

Oversubscription

$$M = \frac{\text{Peak access rate sold to user}}{\text{Average access rate}}$$

~ 2.5 Mb/s in 2008

$M = 25$

~ 0.1 Mb/s in 2008



Power Consumption of IP Network

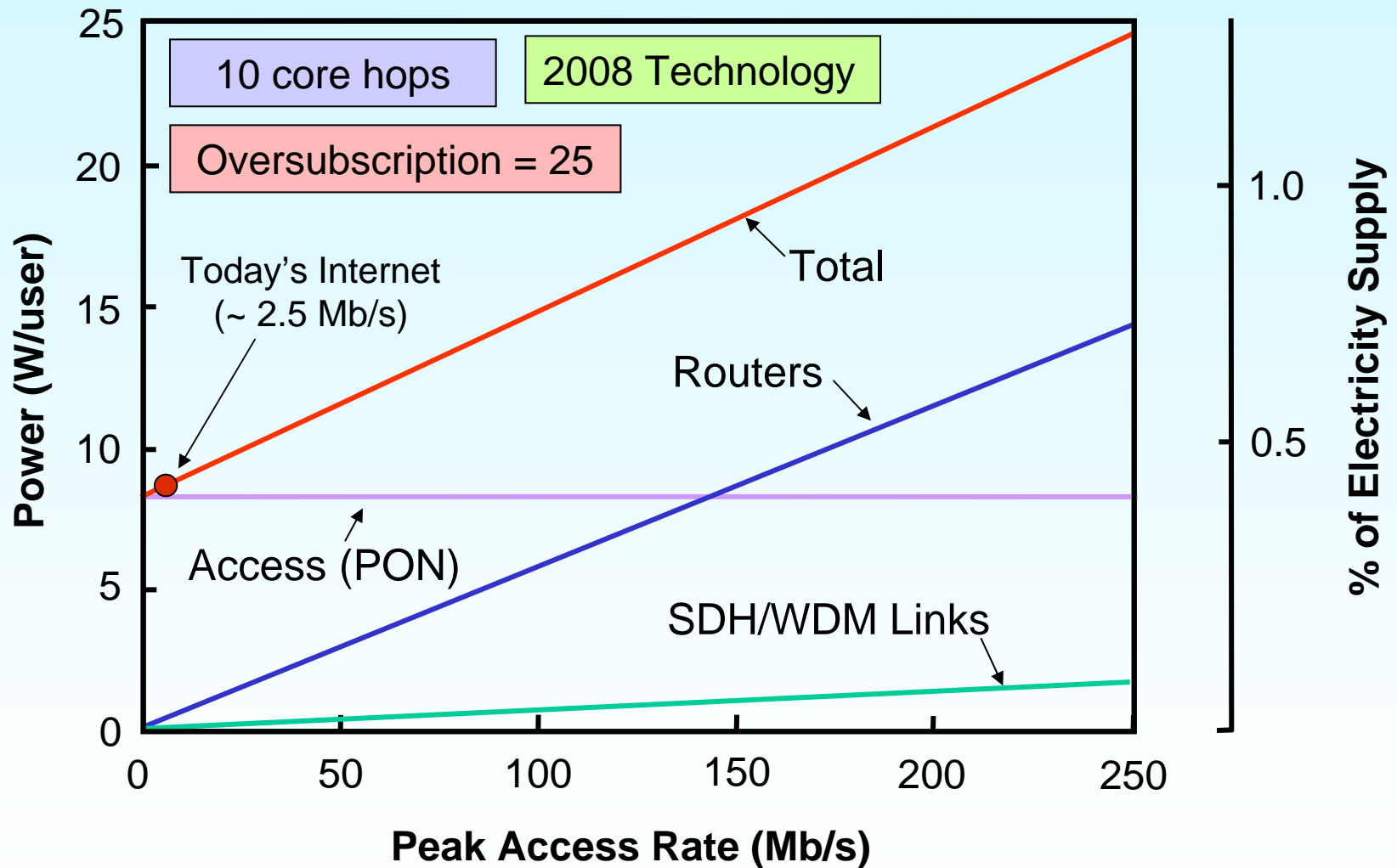

Ultra-Broadband Access

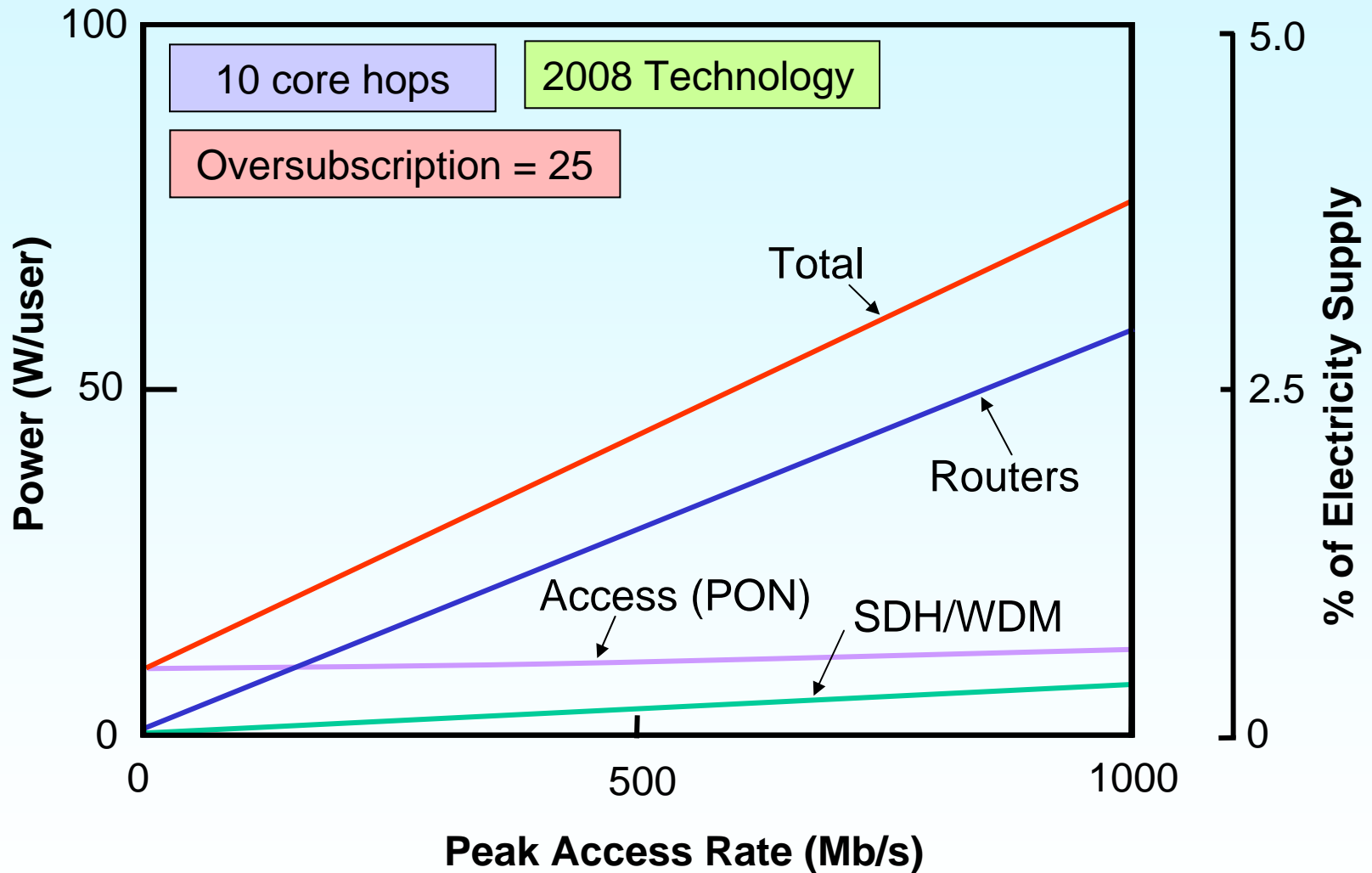

Power Consumption in Access Networks

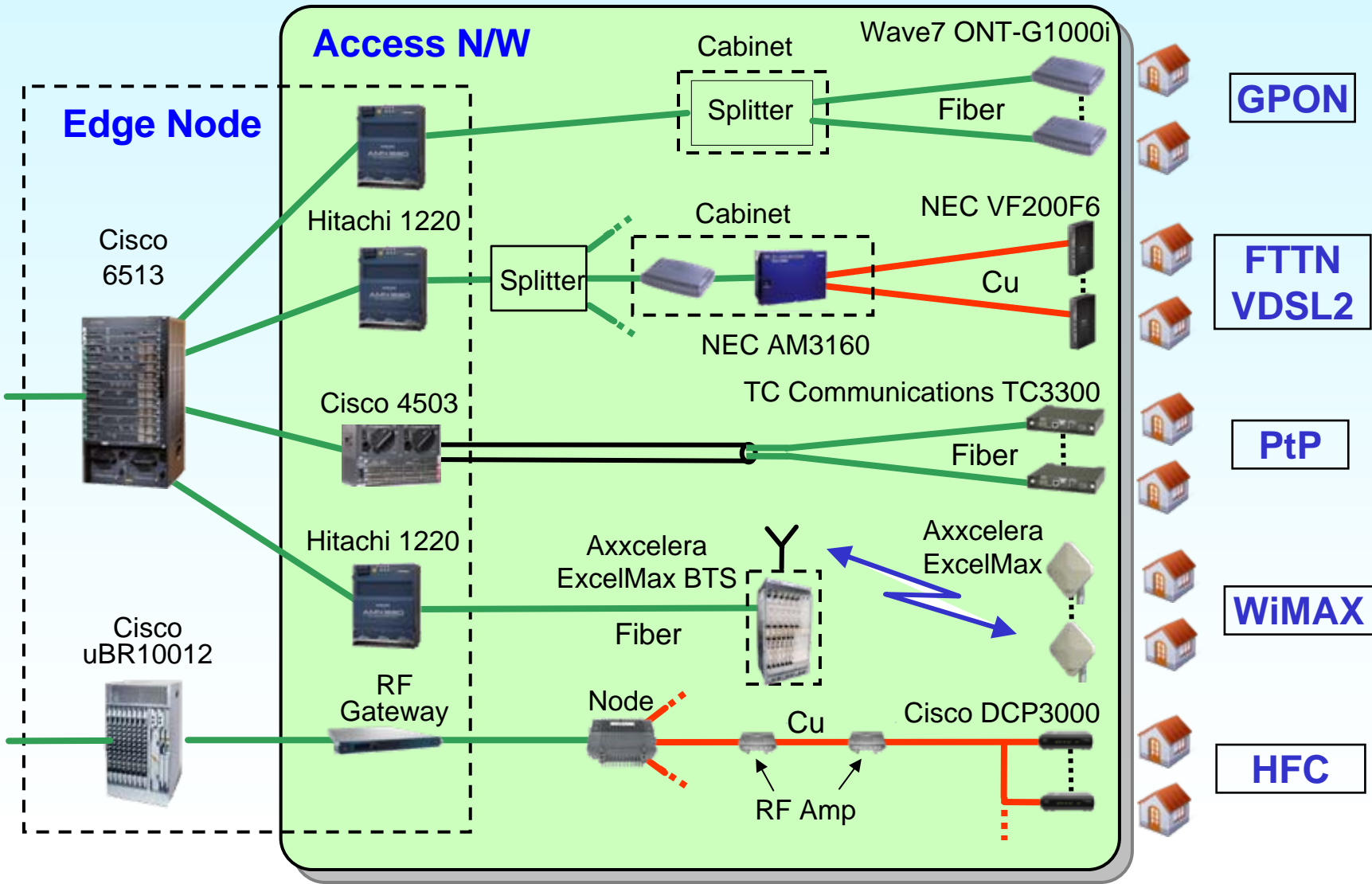

Power Consumption in Access Networks

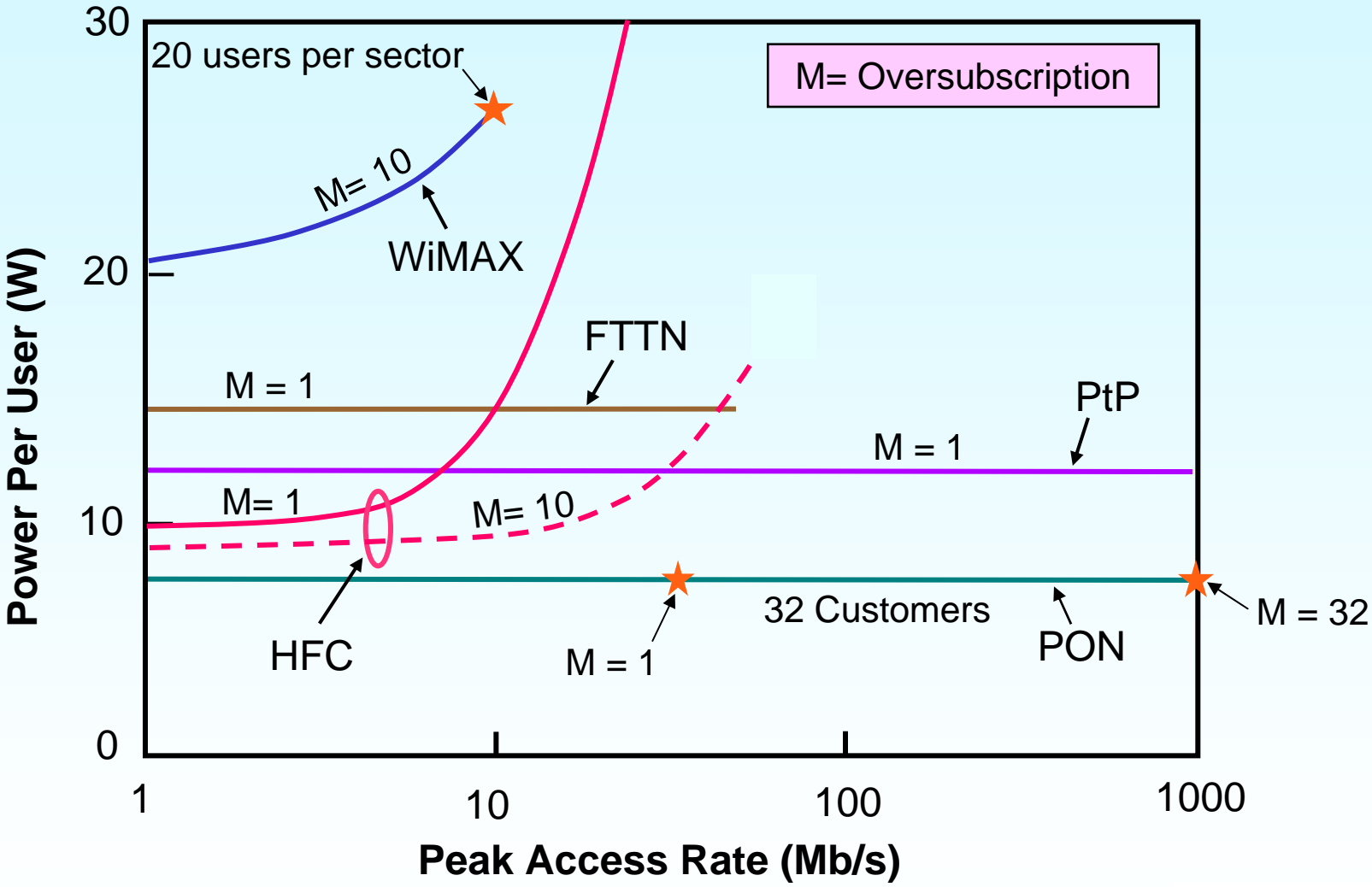

PON FTTH is "greenest"

Low-Power States in User Modems



EUROPEAN COMMISSION
DIRECTORATE -GENERAL JRC
JOINT RESEARCH CENTRE
Institute for the Environment and Sustainability
Renewable Energies Unit

Code of Conduct on Energy Consumption of Broadband Equipment

Draft Version 3

Issue 15 – 17 July 2008

“With implementation of this Code of Conduct the (network) electricity consumption could be limited to 25 TWh per year. This is equivalent to 5.5 Millions tons of oil equivalent (TOE) and to total saving of about € 7.5 Billions per year.”

Extract:

	Off-State (W)	Low-Power State (W)	On-State (W)
ADSL-CPE	0.3	3.5	4.0
VDSL2-CPE	0.3	4.5	6.0
GPON ONU	0.3	5.0	9.0
PtP ONU	0.3	3.0	5.0



Home Networks

Energy consumption

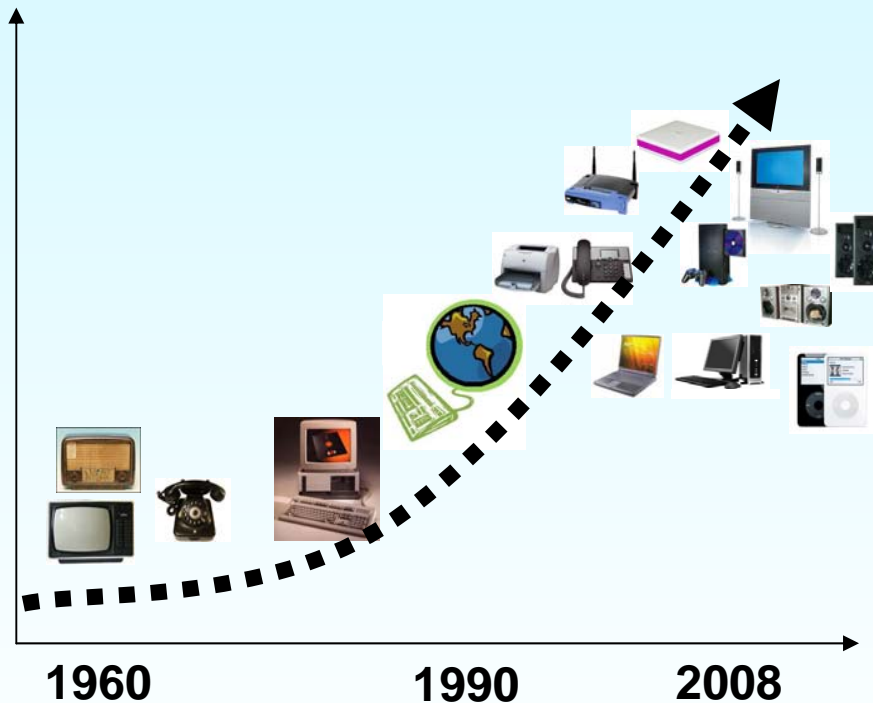

- Dramatic growth of internet due to “multimedia” traffic
 - Any kind of video (on demand, time-shifted, faster than real time)
 - Broadband Internet
 - Audio
 - Voice
- Broadband services require home network equipment
- Size of home networks increases with increasing number of devices
- Home equipment often not used efficiently

Network Energy Consumption per Bit

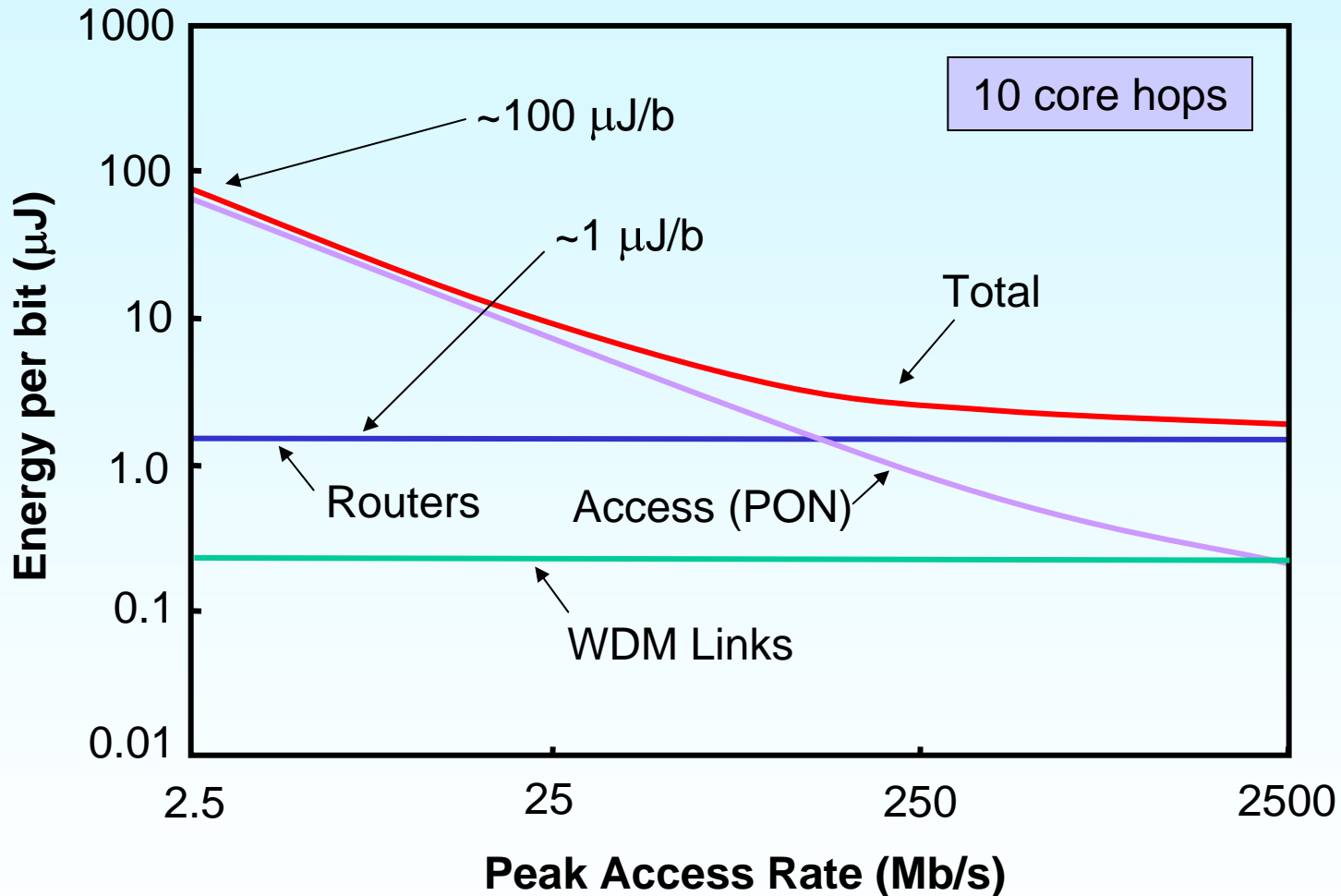

Energy per Bit in Network Devices

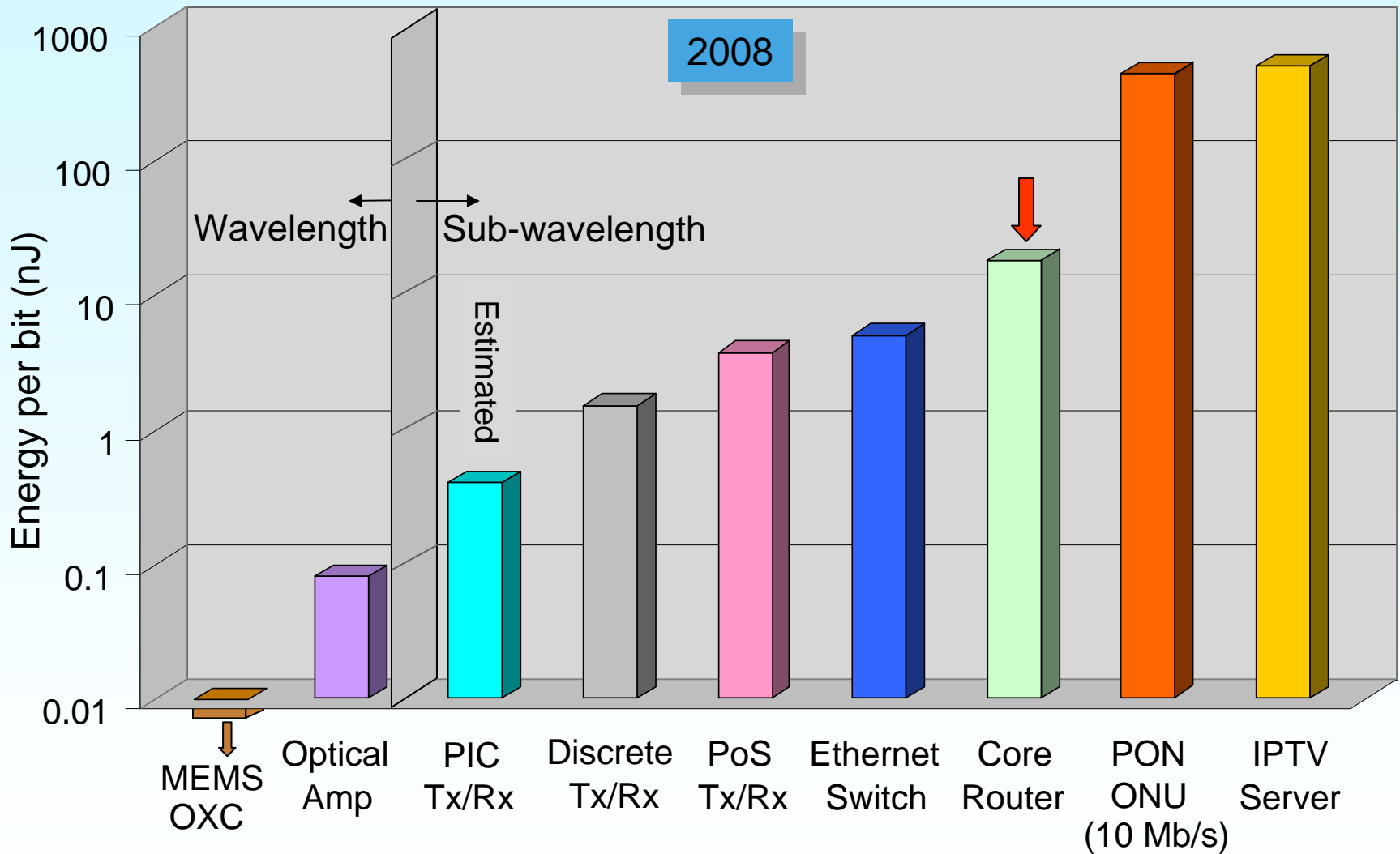

Router Capacity Growth

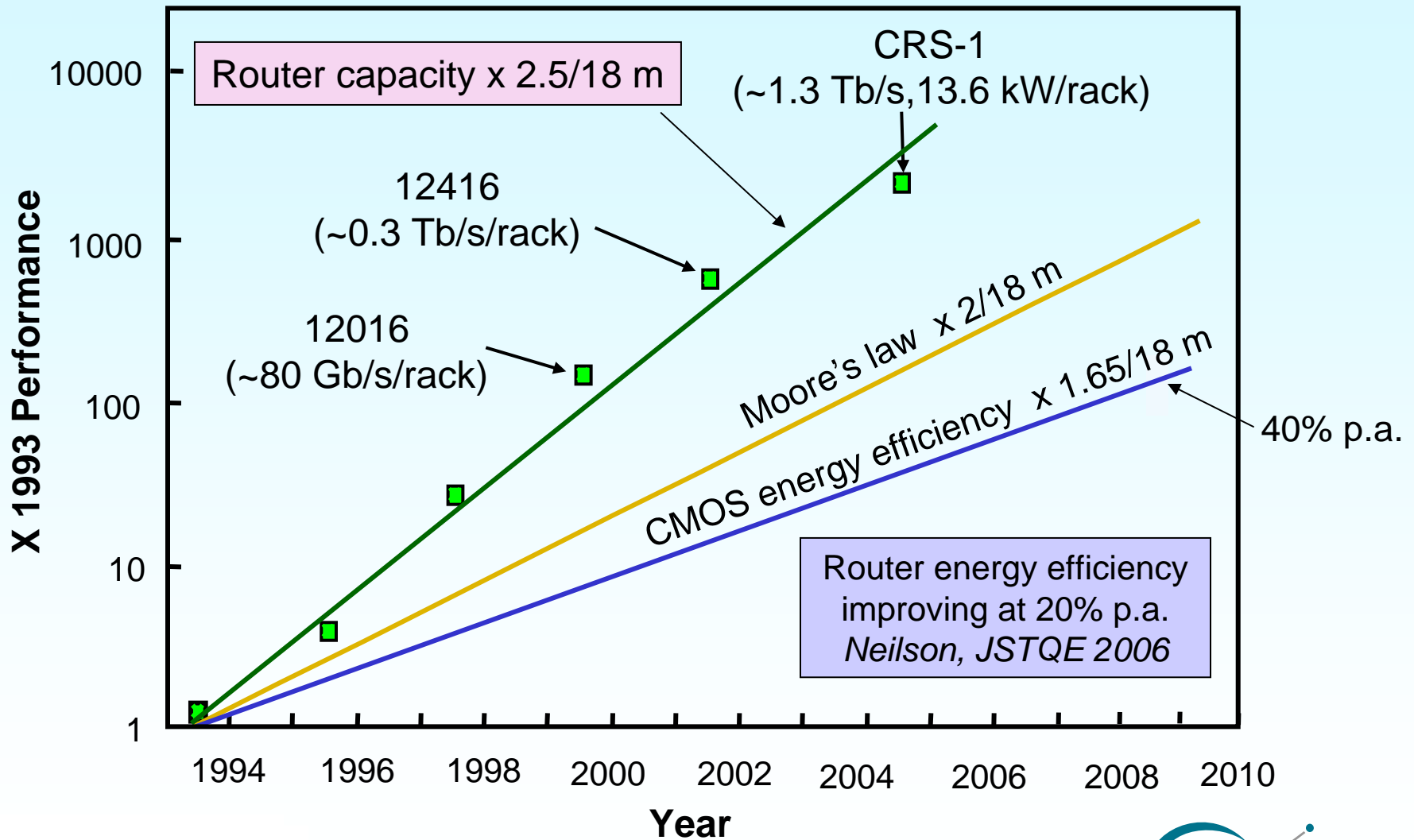

Based on G. Epps, CISCO, 2006



Effect of Efficiency Gains?

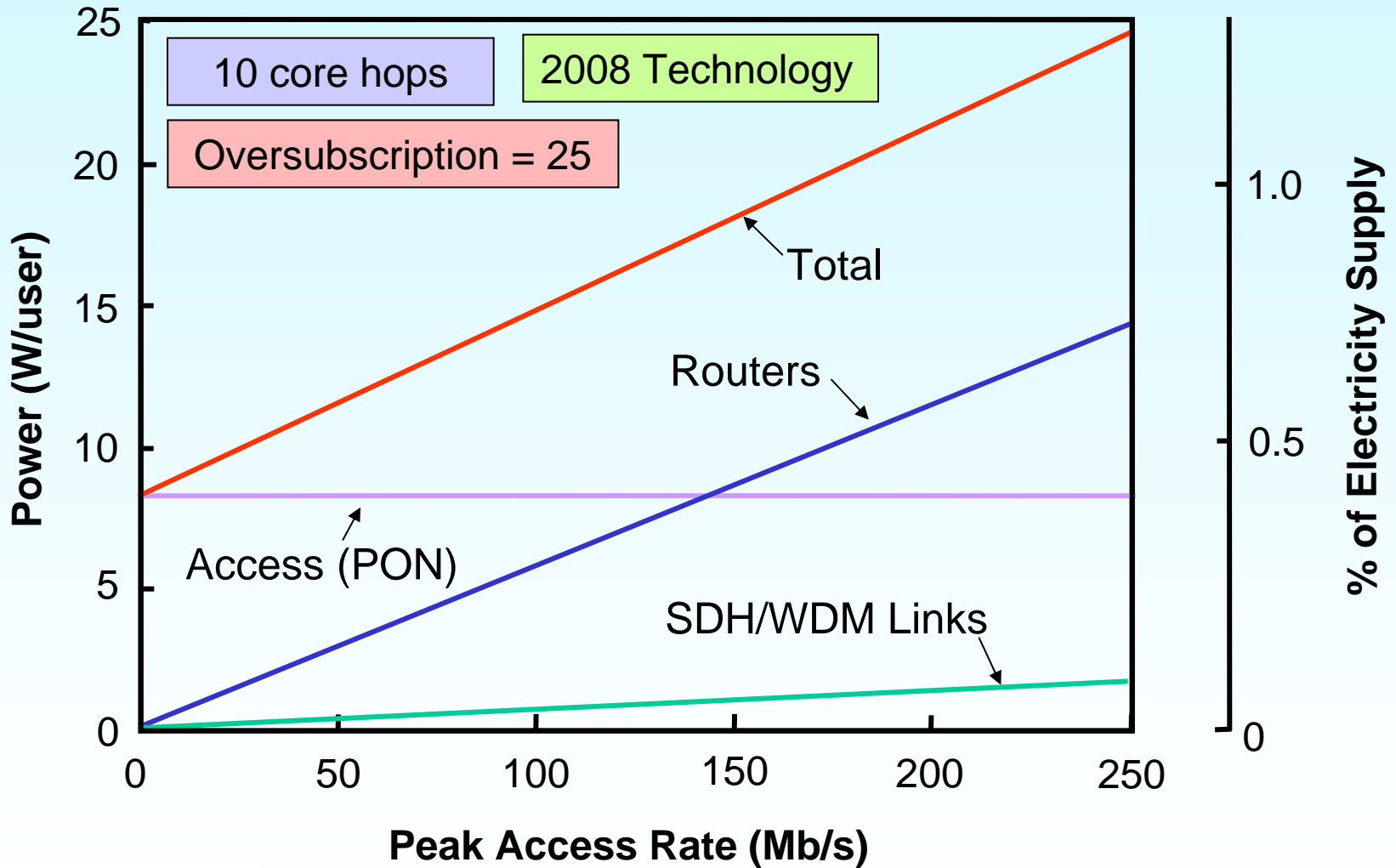

Improvements in Technology Efficiency

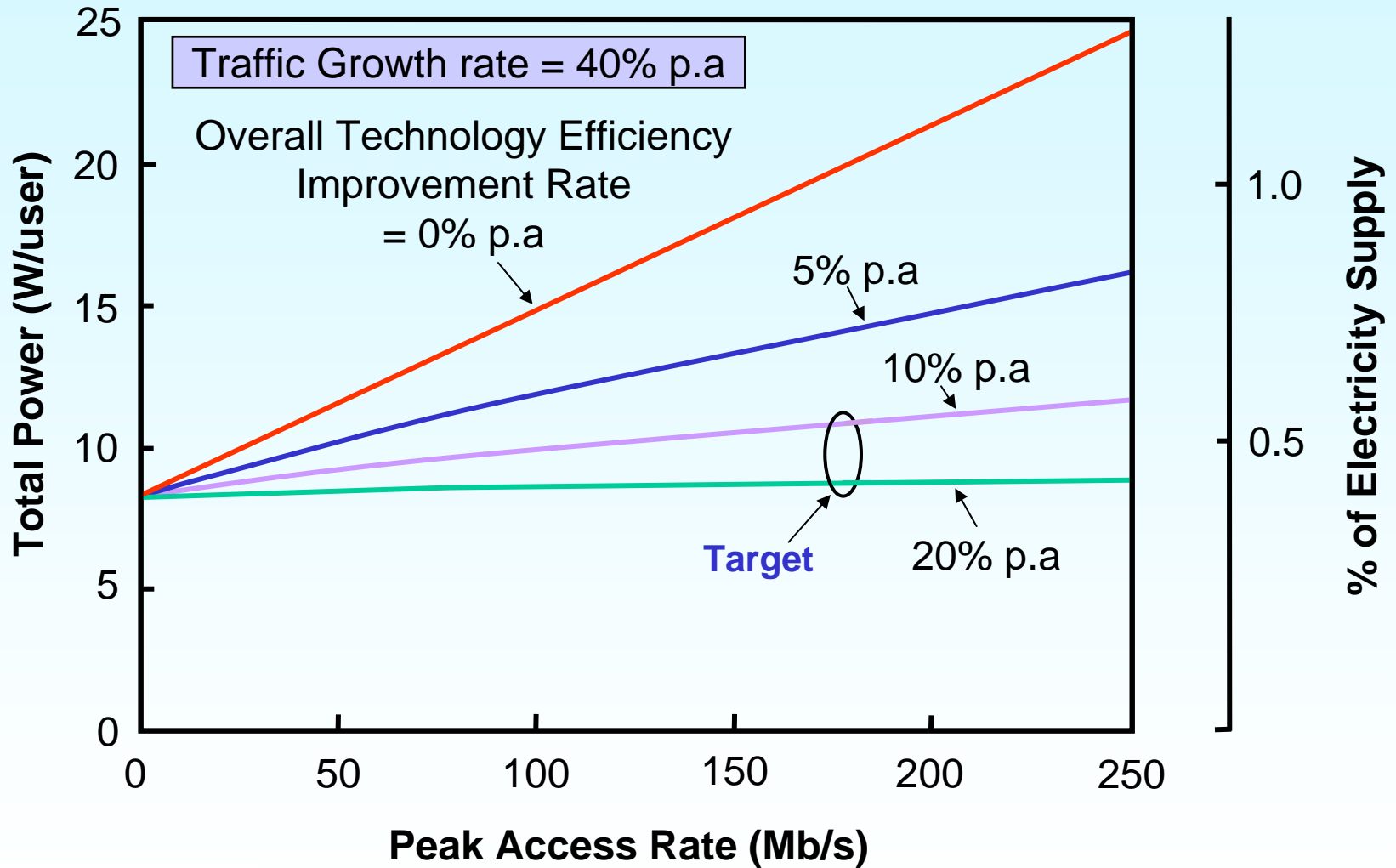

Some Observations

- Optical transport (WDM) consumes relatively little energy
 < 5% of energy > 25% of CAPEX
- Access network dominates consumption at low rates
 - Standby/Sleep mode is key to reducing energy consumption
 - Energy efficiency may be a key driver for FTTH deployment
- Network routers dominate consumption at higher rates
- The “energy bottleneck” will replace the so-called “bandwidth bottleneck”
- Electronics is excellent for switching and signal processing
- Photonics is excellent for transmission



Towards Energy-Efficient Networks

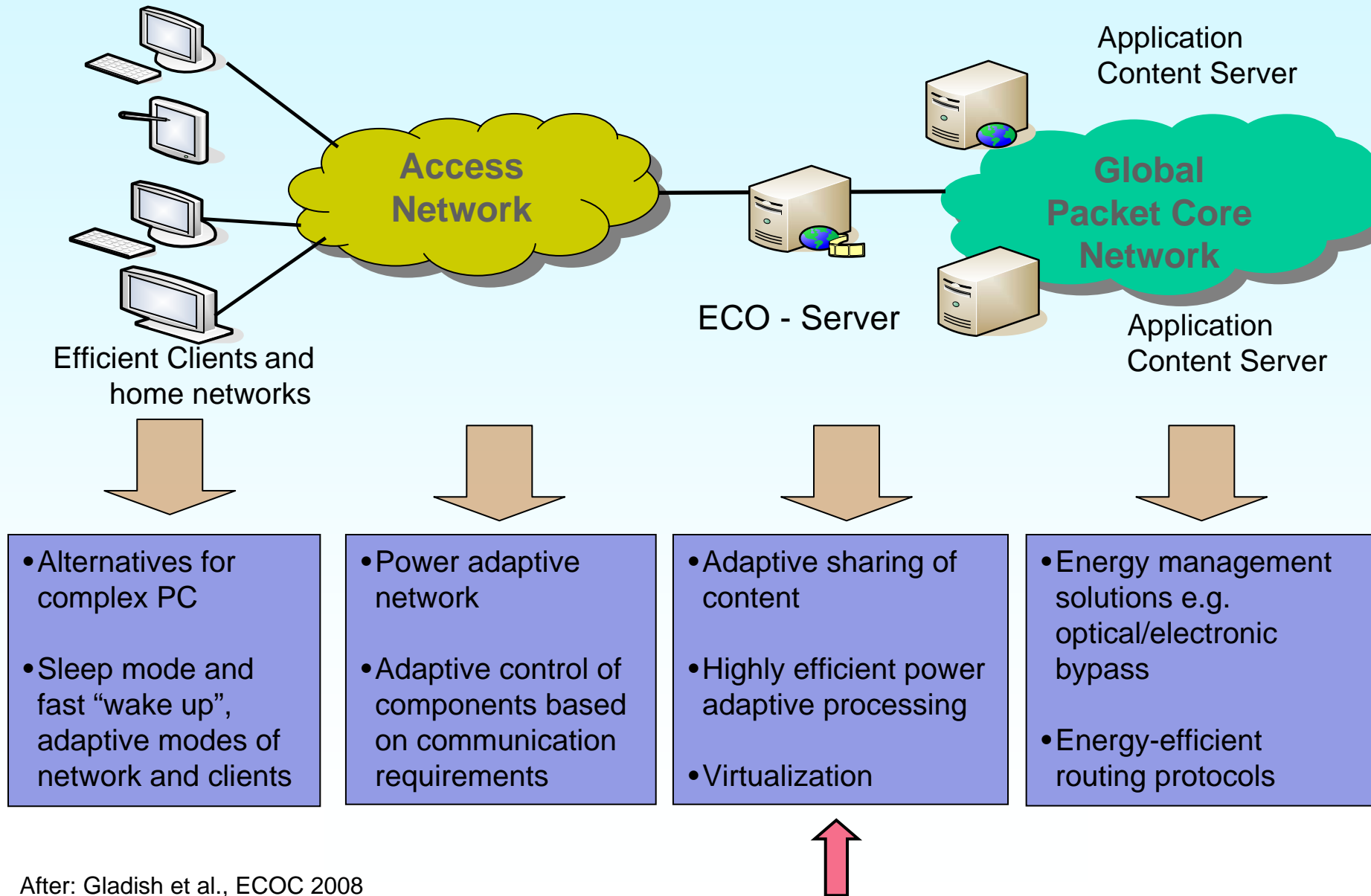

Data Centers

- Data center electricity consumption is ~1% of the global total¹
- Energy consumption of data centers worldwide doubled between 2000 and 2006 ²
- Incremental US demand for data centre energy between now and 2010 is the equivalent of 10 new power plants²



1 MW Data Center

¹Koomey, 2008

²Revolutionizing Data Centre Efficiency—Key Analyses”
McKinsey & Company, April 2008.



Energy Consumption in a Data Center

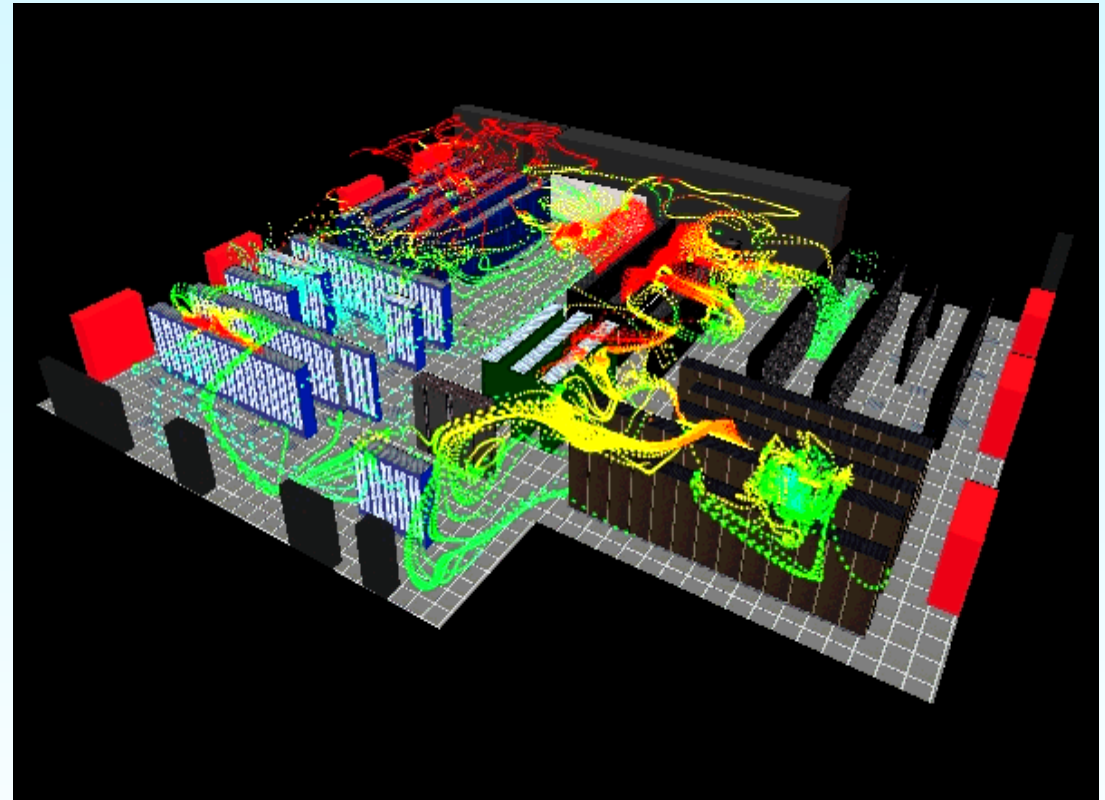
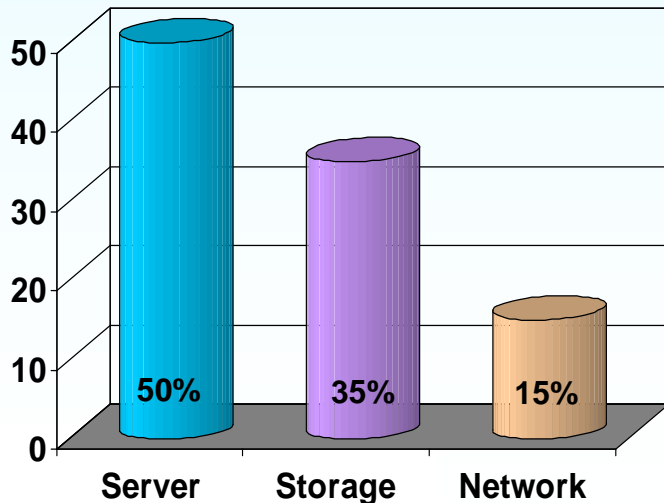
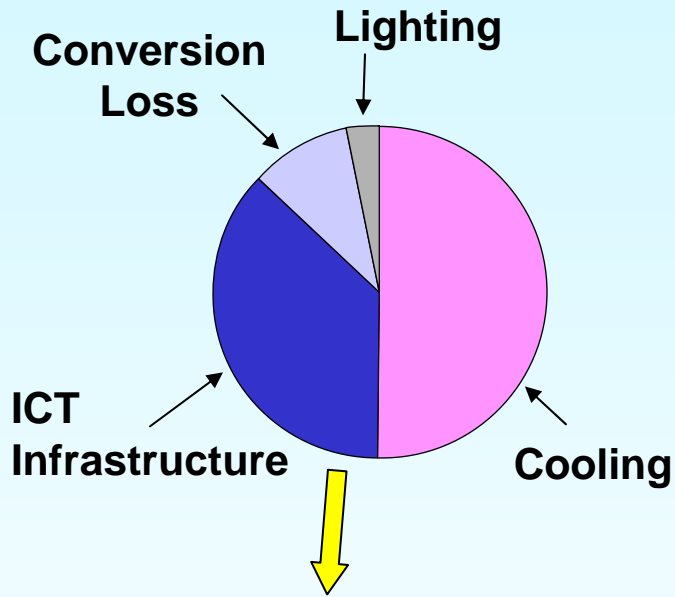

Each watt consumed by IT infrastructure carries a “burden factor” of 1.8 to 2.5 for power consumption associated with cooling, conversion/distribution and lighting

Sources: EYP Mission Critical Facilities, Cisco IT, Network World, Customer Interviews, APC



Using the Internet for Travel Replacement

Video Conferencing



Travel Replacement - Greenhouse Impact (CO₂)

Air Travel

Home



Melbourne



~5,000 kg/person return

LEOS Meeting



Newport Beach

Video Conferencing



2 X 1 Gb/s for 24 hours
= 20 TB



~100 kg/person



Teleportation in place of Video Conferencing?

How much information does the brain hold?

Brain Scans: Southern California Brain Research Institute (SCBRI)

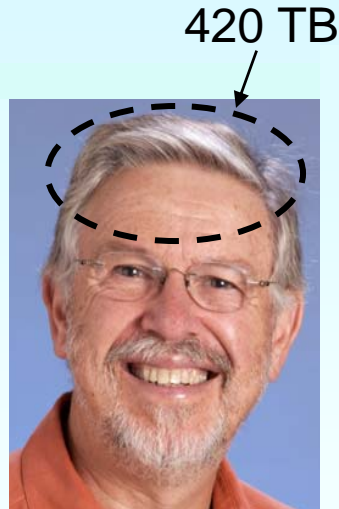

Rod Tucker



John Marsh

Average LEOS member: $(420 + 580)/2 \sim 500$ TB

2,000 kg/person return

(50 MW/person for 5 seconds to teleport in each direction)



Embarrassing Moments in Sci Fi

Teleportation

Beam me up,
Scotty



Sorry, Captain.
The power company has a
new energy-efficiency program.
Please use Skype.

Travel Replacement



Air Travel:

5,000 kg/person return



Melbourne



Teleportation:

2,000 kg/person return



Newport Beach



Video Conferencing:

100 kg/person



Rod's Telecommute Calculator

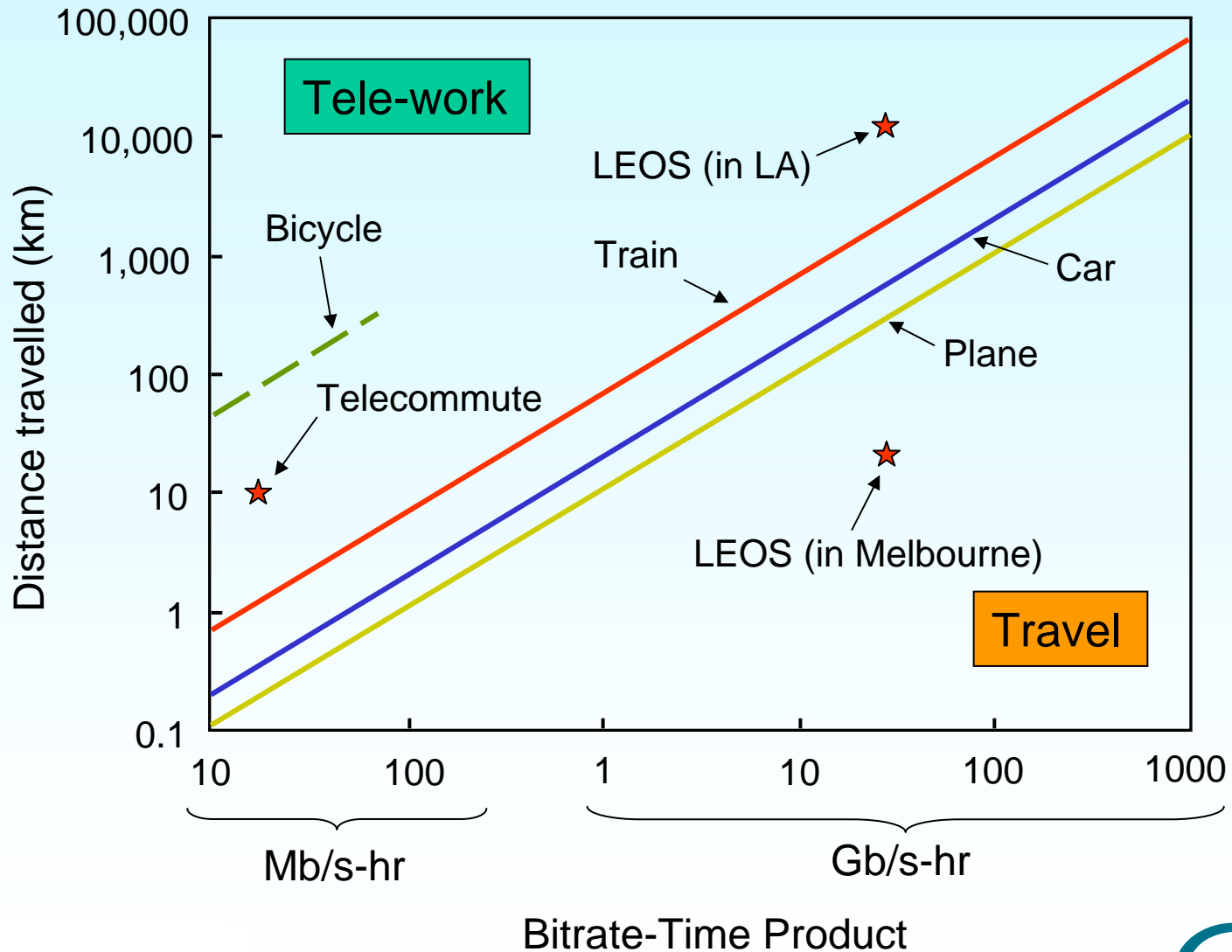

Green Photonics

Low Energy

- PON Access networks
 - GPON, EPON
 - WDM PON
- Optical circuit switching
- Optical bypass
 - low-energy cross connects
 - ROADMs
- Photonic integration
- Optical interconnects
 - Low power Tx/Rx
- Low-energy nanophotonics

Not so Low Energy

- Non-PON Access networks
 - Wireless
 - HFC
 - FTTN
- Sub-wavelength optical switching
 - Optical packet switching
 - Optical burst switching
- Nonlinear optics for logic & DSP



Every bit Counts

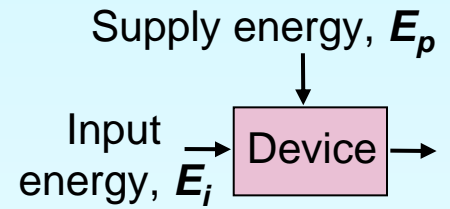
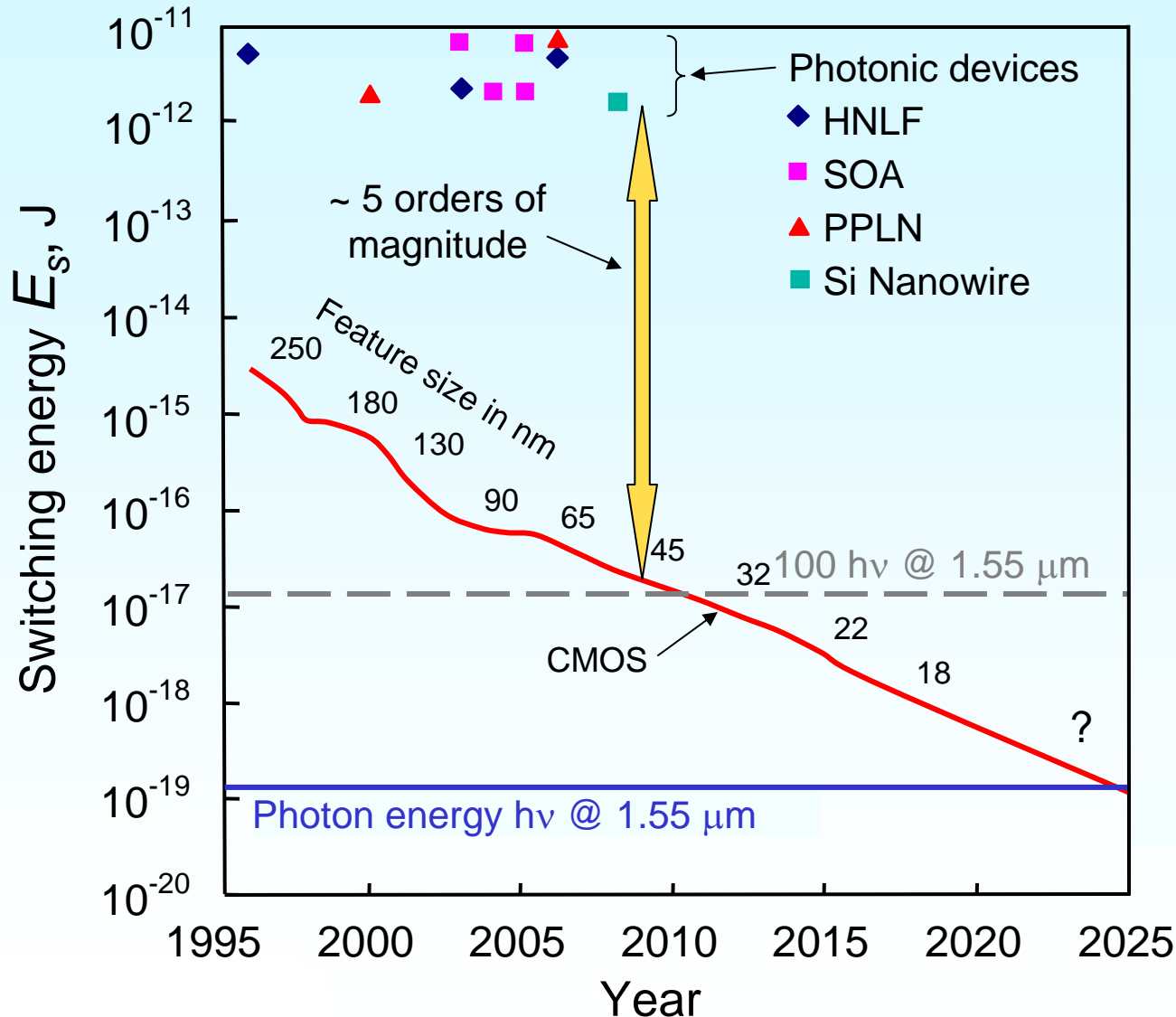

Switching energy

$$E_s = E_i + E_p$$

“If you are thinking of competing with CMOS, don’t”:
Tingye Li, ~1998

I was Wrong

IEEE PHOTONICS TECHNOLOGY LETTERS, VOL. 11, NO. 8, AUGUST 1999

All-Optical Wavelength Translation Over 80 nm at 2.5 Gb/s Using Four-Wave Mixing in a Semiconductor Optical Amplifier

Trefor J. Morgan, *Student Member, IEEE*, Rodney S. Tucker, *Fellow, IEEE*, and Jonathan P. R. Lacey, *Member, IEEE*

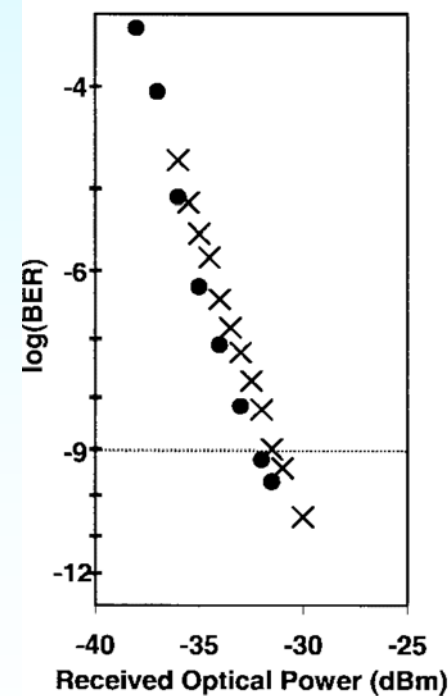
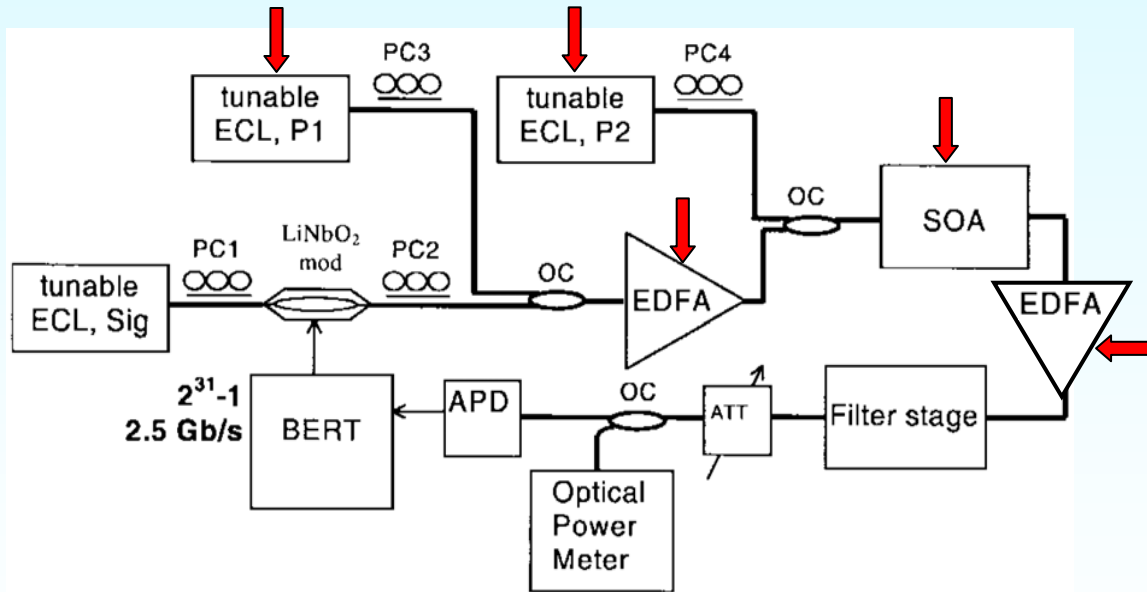

Major flaw: no mention of energy consumption

Energy per bit > 10 nJ/bit

Some International Achievements

- BT has reduced carbon emissions by 60% since 1996
 - Management compensation linked to reductions in energy consumption
- NTT has a major focus on reducing energy consumption
 - “Total Power Revolution” saved 124 million kWh in 2007
- Other initiatives: GeSI, Green Grid, WattWatt, FTTH Council Europe, EU codes of conduct, CBI Task Force etc.



Groups and Organizations



NIPP
Network Interface, Power, and Protection Committee

<http://www.atis.org/0050/>



GeSI
GLOBAL e-SUSTAINABILITY
INITIATIVE

<http://www.gesi.org/>



ITU and
Climate
Change

<http://www.itu.int/climate>



the green grid™
get connected to efficient IT

<http://www.thegreengrid.org/home>

wattwatt
generated by bright sparks

<http://wattwatt.com/>

[ICTandclimatechange.com](http://ictandclimatechange.com)

<http://ictandclimatechange.com/>



Workshops and Conferences

- **ITU Symposium on ICTs and Climate Change, London, 16-17 June, 2008:**
<http://www.itu.int/ITU-T/worksem/climatechange/index.html>
- **Network Solutions to Reduce the Energy Footprint of ICT, ECOC, Brussels, 21-25 September, 2008:**
<http://www.ecoc2008.org/programme.asp#greenict>
- **Symposium on Sustainability of the Internet and ICT, University of Melbourne, November 25-26, 2008:**
http://www.ee.unimelb.edu.au/green_internet/
- **Workshop on Energy Footprint of ICT: Forecast and Network Solutions, OFC 2009**



Summary – The Way Forward

- Energy consumption of the Internet is small, but growing
- Internet energy consumption dominated by
 - Access network today
 - Core network in the future
- A multi-disciplinary approach is required to build a green Internet:
 - Improved efficiency in electronic and photonic devices
 - Low-energy switching techniques
 - Improved architectures
 - New protocols
- Photonics can play a key role
 - **Think Energy**

