

1614W 1310 nm DFB Laser Module

The 1614W 1310 nm wideband wireless DFB laser modules are designed for analog applications requiring an operational bandwidth between 5 MHz and 2700 MHz. The highly linear, OC-48 pinout compatible devices feature up to 25 mW of output power with superior performance over an enhanced operating range of -40 °C to 85 °C.

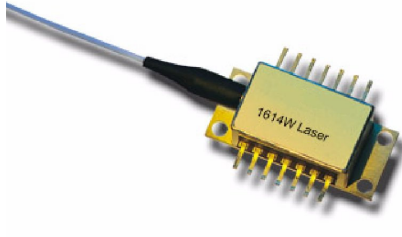

Applications

- Wideband wireless systems
- Satellite signal transmission via fiber
- Narrow transmitter housings
- Networks with limited fiber

Features

- OC-48 pinout
- *Telcordia Technologies*[™] 468 compliant
- Wide temperature range—stable even in harsh environments

Performance Highlights

	Min	Typical	Max	Units
Wavelength	1300	-	1320	nm
Optical Output Power (two versions)	2	-	-	mW
	8	<25	-	mW
Temperature Range	-40	-	+85	°C
Frequency Range	5	-	2700	MHz
Input Third Order Intercept	32	-	-	dBm
1 dB Compression Point	18	-	-	dBm

See following pages for complete specifications and conditions.

Absolute Maximum Ratings

Stresses in excess of the absolute maximum ratings can cause permanent damage to the device. These are absolute stress ratings only. Functional operation of the device is not implied at these or any other conditions in excess of those given in the operational sections of the data sheet. Exposure to absolute maximum ratings for extended periods can adversely affect device reliability.

Parameter	Symbol	Condition	Min	Max	Units
Operating Case Temperature	T_C	continuous	-40	+85	°C
Storage Temperature	T_{STG}	-	-40	+85	°C
Laser Forward dc Current	-	-	-	150	mA
Reverse Voltage Photodiode	V_{RPD}	60 seconds	-	10	V
Laser Reverse Voltage, dc	-	continuous	-	1	V
ESD	-	HBM: R = 1500 Ohm, C = 100 pF	-500	500	V
TEC Current	I_{TEC}	continuous	-1.9	1.9	A

Electrical/Optical Characteristics

Laser Temperature (T_L) = 25°C, $I_F = I_{OP}$, Beginning of Life (BOL)

Parameter	Symbol	Condition	Min	Typ	Max	Unit
Wavelength	λ_{OP}		1300	-	1320	nm
Optical Output Power	P_O	1614xxxx-02 version 1614xxxx-08 version	2 8	- -	- -	mW mW
Optical Isolation	ISO	-	30	-	-	dB
Sidemode Suppression Ratio	SMSR	-	30	-	-	dB
Threshold Current	I_{TH}	-	-	-	30	mA
Operating Current	I_{OP}	-	-	-	120	mA
Monitor PD Responsivity	r_{PD}	$V_{RM} = 5V$	10	-	200	$\mu A/mW$
Thermistor Resistance	R_{TH}	$T_{OP} = 25^\circ C$	9.5	10	10.5	KOhm
Thermistor Temp. Coefficient	TC_{TH}	$T_{OP} = 25^\circ C$	-	-4.4	-	%/°C
TEC Current	I_{TEC}	$-40 < T_C < +85^\circ C$; $I_F = 100mA$	-1.5	-	1.6	A
Fiber Length	-	May include splice	1.0	1.5	-	m
Fiber Buffer	-	-	-	900	-	μm
Fiber Core / Cladding	-	-	-	9/125	-	μm

RF Characteristics

Laser Temperature (T_L) = 25°C, $I_F = I_{OP}$, Beginning of Life (BOL)

Parameter	Symbol	Condition	Min	Typ	Max	Units
Frequency Range	F	-	5	-	2700	MHz
Frequency Response	S21	Any 500 MHz 5-2700 MHz	- -	2 4	- -	dB, p-p dB, p-p
Input Third Order Intercept	IIP3	-	32	-	-	dBm
1 dB Compression point	-	-	18	-	-	dBm
Nominal Input Impedance	Z_{IN}	-	-	25	-	Ohms
Return Loss – Tested w/ resistive match 50 Ω to 25 Ω pad	S11	-	16	-	-	dB

In order to prevent reflection-induced distortion, the laser must be connected to an optical cable having a return loss of at least 55 dB for discrete reflections and 30 dB for distributed reflections.

Electrical Schematics

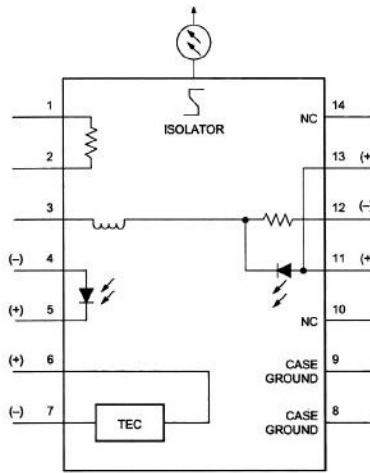

Figure 1. 1614 W Laser Schematic

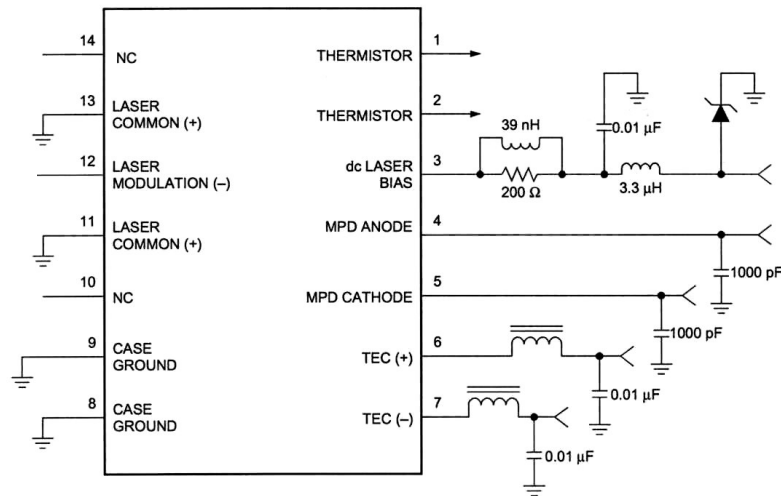
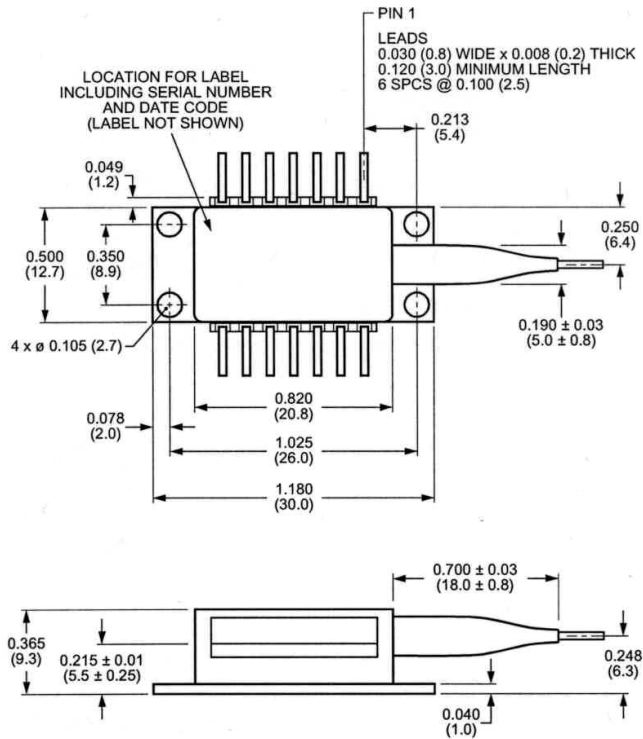

Figure 2. 1614W Circuit Schematic

Outline Diagram

Dimensions are in inches and (millimeters)



Pin Information

Pin No.	Description
1	Thermistor
2	Thermistor
3	Dc Laser Bias (-)
4	MPD Anode (-)
5	MPD Cathode (+)
6	Thermal Electric Cooler (+)
7	Thermal Electric Cooler (-)
8	Case Ground
9	Case Ground
10	NC
11	Laser Common (+)
12	Laser Modulation (-)
13	Laser Common (+)
14	NC

Laser Safety

Class IIIb Laser Product

FDA/CDRH Class IIIb laser product. All versions are Class IIIb laser products per CDHR 1040 Laser Safety Requirements. All versions are class 3B laser products per IEC® 60825-1:1993. The device has been classified with the FDA under accession number 220191.

This product complies with 21 CFR 1040.10 and 1040.11.

Single-mode fiber pigtail

Wavelength = 1310nm

Maximum power = 50 mW

Because of size constraints, laser safety labeling (including an FDA class IIIb label) is not affixed to the module but attached to the outside of the shipping carton.

Product is not shipped with power supply.

Caution: Use of controls, adjustments and procedures other than those specified herein may result in hazardous laser radiation exposure.

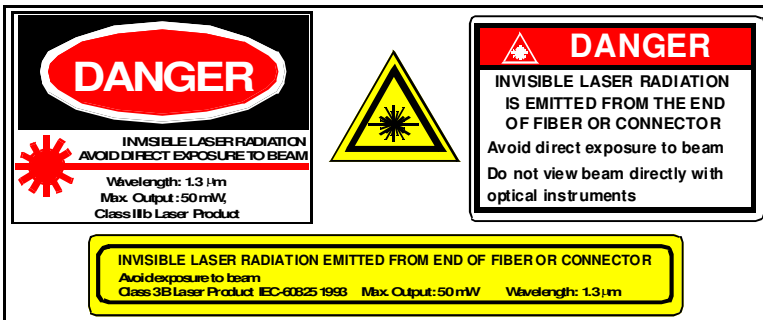

Ordering Information

Contact Ortel for ordering information at 626-293-3400.

Ordering Code Definitions

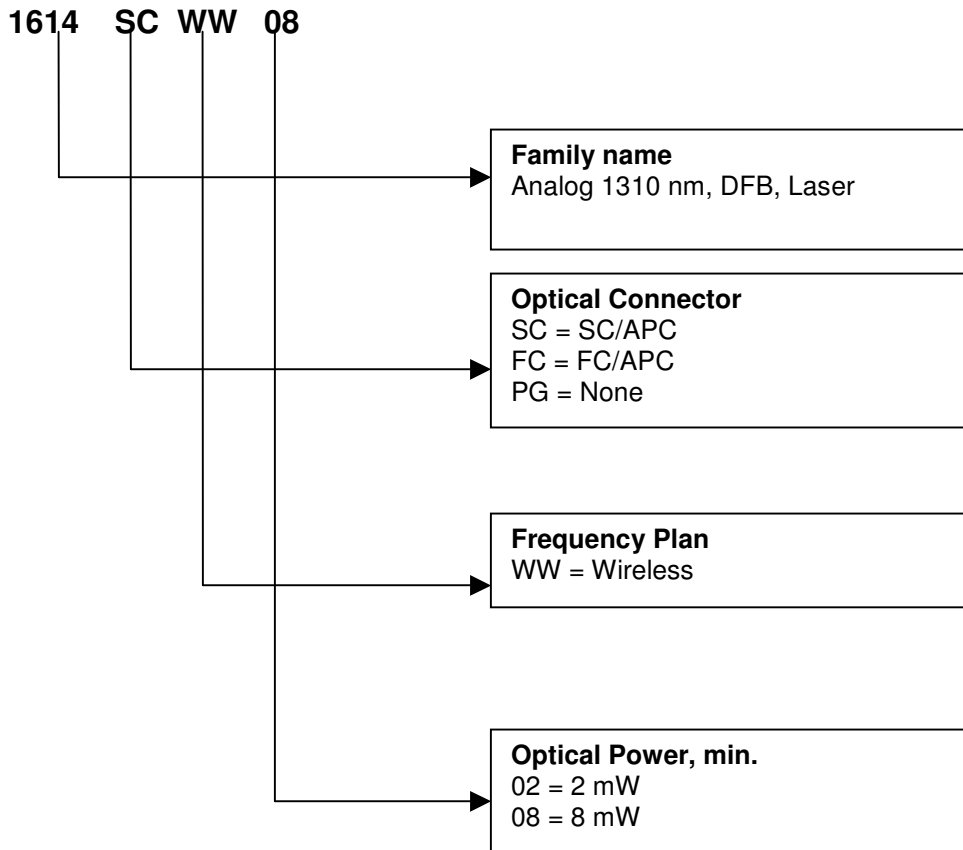

Information contained herein is deemed to be reliable and accurate as of issue date. EMCORE reserves the right to change the design or specifications of the product at any time without notice. Ortel, the Ortel logo, EMCORE, and the EMCORE logo are trademarks of EMCORE Corporation.



Ortel, a division of EMCORE

2015 West Chestnut Street
Alhambra, California 91803-1542
Tel: 626-293-3400
Fax: 626-293-3428
www.emcore.com

