

**UNIVERSITY OF CALIFORNIA, SANTA BARBARA**  
**Department of Electrical and Computer Engineering**

**ECE 2A & 2B**  
**Laboratory Equipment Information**

**Table of Contents**

Digital Multi-Meter (DMM) .....	1
Features .....	1
Using the DMM .....	1
DC Power Supply .....	2
Features .....	2
Using the DC Power Supply .....	3
Supplying a positive DC voltage .....	3
Supplying a negative DC voltage .....	3
Function Generator .....	4
Features .....	4
Using the Function Generator .....	5
Oscilloscope .....	6
Viewing One Signal .....	6
Viewing Two Signals .....	6
Reading the Display .....	7
Vertical Controls .....	8
Horizontal controls .....	9
Taking Measurements .....	9
Measuring a signal .....	10
Using Cursors .....	10
Measuring Voltage .....	10
Measuring Rise Time .....	11
Measuring Phase Difference .....	11
Analyzing a Noisy Signal .....	12
Coupling .....	12
Breadboard .....	13

## Digital Multi-Meter (DMM)

Used measure DC voltage, current and resistance

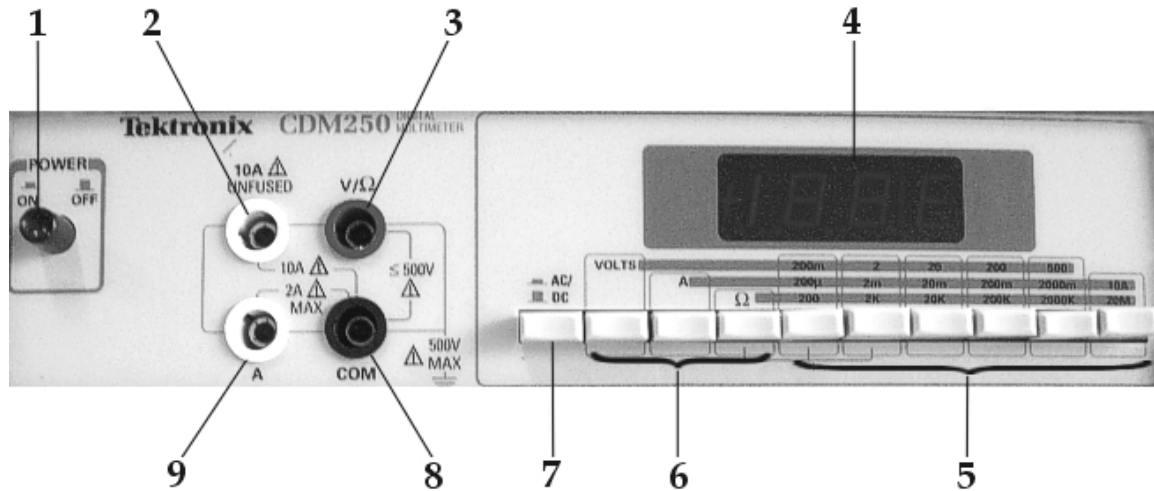

Figure 1. Front Panel of the Digital Multi-Meter

### Features

1. POWER button
2. 10A UNFUSED jack. The red lead plugs in here to measure high current over 2A but below 10A.
3. V- $\Omega$  jack. The red lead plugs in here to measure both voltage and resistance.
4. LED display. Displays the value measured by the DMM.
5. RANGE buttons. These buttons allow you to select the highest value of voltage, current, or resistance you're measuring (see "Using the DMM," below).
6. FUNCTION buttons. Push only one of these buttons to select the type of measurement you're making. *Volts* should be depressed to measure voltage, *A* for current, and  $\Omega$  for resistance.
7. AC/DC button. Depress this button only when you want to measure AC. (In this lab, we typically use the DMM to measure DC only.)
8. COM jack. The black lead plugs in here for all measurement purposes.
9. 2A jack. The red lead plugs in here to measure low levels of current under 2A.

### Using the DMM

Before using the DMM, be sure to plug your leads into the proper input (2, 3, 8 and 9 in the Figure above) and select the appropriate function button (6). Among the most important features of the DMM are the range buttons. They vary the precision of your measurement by moving the placement of the decimal point displayed on the LED. The numbers above each the range buttons represents the largest possible value for that particular setting. If the range is set too low for your measurement, the LED displays a "1" and you must change the range to a higher maximum range value. For example, if you are measuring voltage and have the range set to the 20 V button, the highest possible

voltage you can measure is 20 V. If the voltage you are trying to measure is actually 20.4 V, the LED will display a 1 and you should to increase your range to 200V.

### DC Power Supply

The DC power supply can provide a constant voltage and/or constant current source to your circuit. It consists of two identical, independently adjustable DC power supplies that can vary the voltage from 0 to 30V and the current from 0 to 2A.

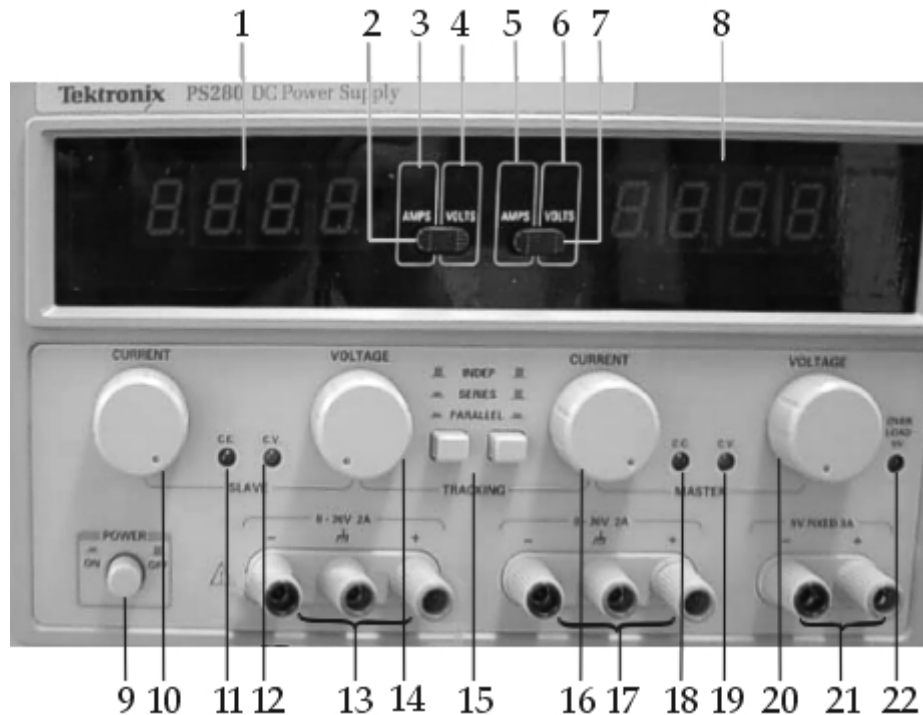

Figure 2. Front Panel of the DC Power Supply

### Features

1. LED display for left power supply. (8. LED display for right supply.)
2. AMPS/VOLTS switch for left power supply. (7. AMPS/VOLTS switch for right supply.)
3. AMPS indicator light for left power supply. (5. AMPS indicator light for right supply.)
4. VOLTS indicator light for left power supply. (6. VOLTS indicator light for right supply.)
9. POWER button.
10. CURRENT knob, used to set the maximum current for left power supply. (16. CURRENT knob for right supply.)
11. Constant current (C.C.) indicator for left power supply. (18. C.C. indicator for right supply.)
12. Constant voltage (C.V.) indicator for left power supply. (19. C.V. Indicator for right supply.)

13. OUTPUT terminals for left power supply. (17. OUTPUT terminals for right supply.)
14. VOLTAGE knob, used to set the voltage level for left power supply. (20. VOLTAGE knob for right supply.)
15. TRACKING buttons used to establish when right and left supplies are in parallel, series, or independent.
21. 5V FIXED output terminals.
22. OVERLOAD indicator light for fixed output terminal.

### Using the DC Power Supply

#### *Supplying a positive DC voltage*

1. Set the AMPS/VOLTS switch to VOLTS (2, in the Figure above).
2. Use the voltage knob (14) to set the voltage to the desired value. (If the voltage doesn't seem to go high enough, make sure the current knob (10) is turned on. The current should be set to the lowest possible value to achieve the desired voltage. This avoids potentially damaging devices and components that have current limitations.)
3. Connect the supply to your circuit, using two of the three output terminals (13). The red terminal on the right is the positive output-- connect this to your circuit as your input voltage. The black terminal on the left is the negative output-- connect this lead to your circuit ground (this makes it the reference). The green terminal in the middle is earth ground, and can be disregarded in this lab.

#### *Supplying a negative DC voltage*

1. Set the AMPS/VOLTS switch to VOLTS
2. Use the voltage knob (14) to set the voltage to the desired positive value (for example, to supply  $-15\text{V}$ , turn the knob to 15). If you're having problems adjusting the voltage, make sure the current knob is turned on.
3. Connect the red positive output to your circuit ground (this sets it to  $0\text{V}$  reference). The black negative output will now be  $-15\text{V}$ .

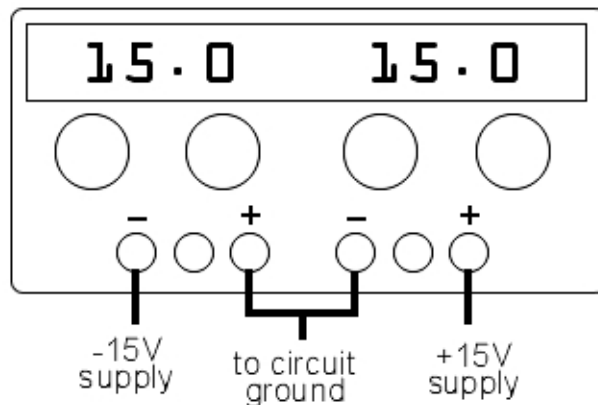

**Figure 3. Supplying +15V and -15V for Op-amps**

## Function Generator

The function generator is a device used to produce AC signals in the form of low-distortion sine waves, square waves, triangle waves, TTL sync signals, positive and negative pulses, and ramp waveforms. The amplitude and frequency of the signals are user controlled. The amplitude can be varied from 0-20 VPP and the frequency from 0.1 Hz to 11 MHz.

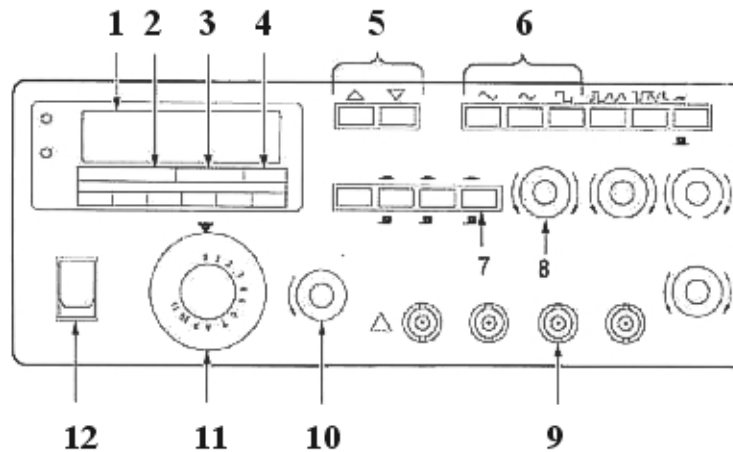

Figure 4. Front Panel of the Function Generator

### Features

1. **FREQUENCY DISPLAY** is a five-digit display that shows the frequency counter values. The decimal point is automatically placed depending on the settings and resolution.
2. **MULTIPLIER LEDs** indicate the frequency multiplication factor of the function generator outputs. The 10-1M LED indicates a multiplication factor of 10 to  $10^5$ .
3. **FREQUENCY RANGE LEDs** indicate the range (either MHz or kHz) of the reading shown on the Frequency Display. For example, if the Frequency Dial is set to 9, the 10-1 M LED is lit, the kHz LED is lit, the counter readout shows 0.090, then the output frequency is 0.090 kHz = 90 Hz.
4. **SEC LED** indicates when the Frequency Display is in period mode. This means the Frequency Display does not show frequency in Hz, but shows the period in seconds. For example, if the Frequency Dial is set to 4, the Multiplier LED is lit, the Sec LED is lit, the frequency display shows a value of 0.25, and the generator's output has a period of 0.25 s (or a frequency of 4 Hz).
5. **MULTIPLIER BUTTONS** set the frequency range. The left button raises the range by a power of ten and the right button lowers the range by a power of ten. For example, if the Frequency Dial is set to 4.7 and the output is set to kHz, when you press the left multiplier button, the output frequency will jump from  $4.7 \times 10^3$  Hz (4.7 kHz) to  $4.7 \times 10^4$  Hz (47 kHz).
6. **FUNCTION BUTTONS** select the type of waveform generated: sine, triangle, or square wave.
7. **MAIN BUTTON** toggles between two voltage ranges: 0-2 VPP and 0-20 VPP. For small signals, the button should be set in the position for the range of 0-2 VPP

- so you can get the most accuracy.
8. AMPLITUDE KNOB adjusts the amplitude of the signal within the range specified by the Main Button.
  9. MAIN OUT BNC. This connector is where you attach the lead for your signal output.
  10. FREQ FINE ADJ KNOB. This knob allows for small adjustments in the set frequency.
  11. FREQUENCY KNOB. This knob sets the numerical value of the frequency. Used with the Multiplier Button and the Fine Frequency Knob, this knob allows you to set the exact desired frequency.
  12. POWER SWITCH. This switch turns the instrument on and off.

### Using the Function Generator

1. Press the appropriate Function Button (**6**, in the Figure above) for your desired type of waveform.
2. Set the frequency using the Frequency Knobs (**11** and **10**) to set the value and the Multiplier Buttons (**5**) to set the proper magnitude.
3. Check that the Main Button (**7**) is set to the proper output range.
4. Connect a cable from the function generator's Main Out (**9**) to the CH1 input of the Oscilloscope.
5. Use the oscilloscope's **Measure** feature to measure the peak-to-peak voltage of the signal. (See *Taking Measurements* section of the *Oscilloscope* information.)
6. Adjust the Amplitude Knob (**8**) on the Function Generator until you reach the desired voltage amplitude.

## Oscilloscope

The oscilloscope is a device used to visually display and measure AC signals. The screen displays a digital waveform representation of the signal with voltage on the vertical axis and time on the horizontal axis. The oscilloscope can automatically scale the display grid based on the amplitude and frequency of your signal, and can easily measure Peak-to-Peak or RMS voltages, as well as frequency and period of a signal. It can also analyze two signals simultaneously on CH1 and CH2, which is handy for comparing the input and output signals from an AC circuit.

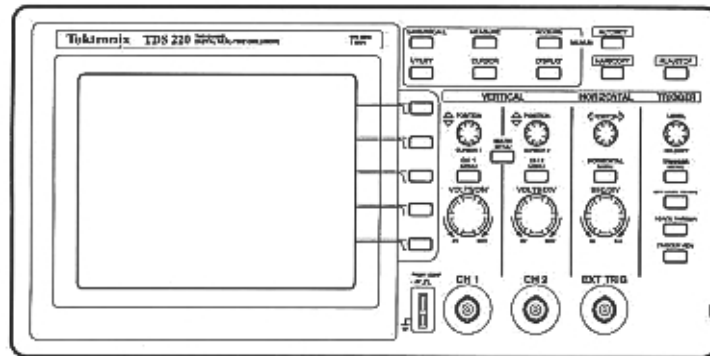

Figure 5. Front Panel of the Oscilloscope

### Viewing One Signal

Connect a probe from the signal source to the **CH1** input to the oscilloscope. Push the **AUTOSET** button, located to the right of the Menu Panel. This automatically adjusts the vertical and horizontal display settings to fit the incoming signal on the screen. It is the easiest way to quickly view a signal. However, it may be necessary to manually adjust the Vertical and Horizontal display controls to get “the whole picture” or to “zoom-in” on an area of interest. See below sections on *Vertical Controls* and *Horizontal Controls* on how to make the appropriate adjustments. Also, see below section on *Taking Measurements* to characterize your signal quantitatively.

### Viewing Two Signals

Connect a probe from one signal source to **CH1** and the other signal to **CH2**. Press **AUTOSET**. If both signals are not automatically displayed, press the **CH1 MENU** button and **CH2 MENU** button and then press **AUTOSET** again. To visually compare the two signals, you may need to adjust the Vertical Controls, such as the Vertical Position of each waveform and the vertical scale (Volts/Div) of each. Note that although they may appear the same size on the screen, the Volts/Div scale may be different for the two signals. See below sections on *Vertical Controls* and *Horizontal Controls* on how to make the appropriate adjustments. Also, see below section on *Taking Measurements* to characterize the signals quantitatively.

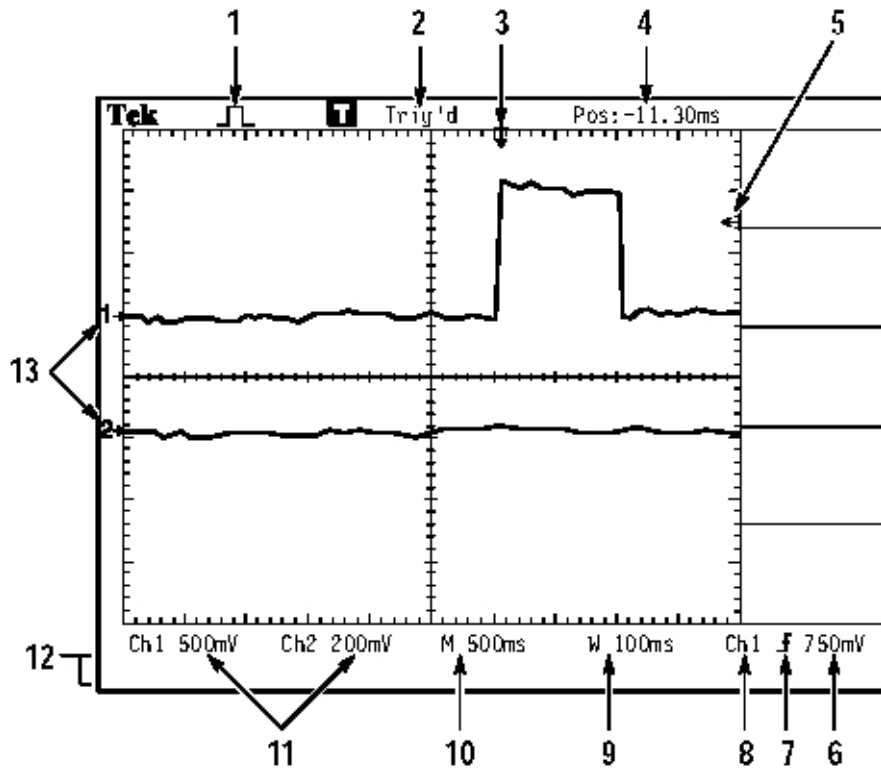

Figure 6. Oscilloscope Display

### Reading the Display

Figure 6 above shows the Oscilloscope screen with two signals. Most of the following display details are unimportant in this lab course, but pay attention to #11 and #13.

1. Icon display shows acquisition mode (Sample, Peak detect, or Average).
2. Trigger status (Armed, Ready, Triggered, Auto, Scan, Stop)
3. Marker shows horizontal trigger position. This is adjusted by the Horizontal Position control.
4. Readout shows the time difference between the center graticule and horizontal trigger position. Center screen equals zero.
5. Marker shows trigger level.
6. Readout shows numeric value of the trigger level.
7. Icon shows selected trigger type (Rising edge, Falling edge, Video Line or Field Sync)
8. Readout shows trigger source used for triggering.
9. Readout shows window time base setting if it is in use.
10. Readout shows main time base setting.
11. Readouts show the vertical scale factors of the channels. (Volts/Division)
12. Display area shows on-line messages momentarily.
13. On-screen markers show the ground reference points of the displayed waveforms. No marker indicates the channel is not displayed. The ground reference can be changed with the Vertical Position Control.



## Vertical Controls

These controls allow you to manually move the signal up and down on the display as well as change the Volts/Division scale of the display (that is, how much of the waveform is displayed vertically).

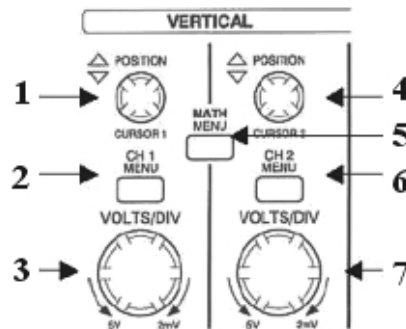

Figure 7. Vertical Controls

1. POSITION/CURSOR 1 KNOB. This knob moves the signal from CH1 up and down on the display. It is helpful to adjust the vertical position when viewing two signals simultaneously.
2. CH1 MENU BUTTON. This button shows the menu for CH1. It also serves as a display switch so that the signal on CH1 can be turned on or off on the screen. The two features you might use from this menu are the PROBE and INVERT options. The PROBE option acts as a multiplier of the incoming signal. For example, if the VOLT/DIV knob for CH1 is set to 2 V/DIV and the probe is set to 1X, the voltage shown on the display is 2 V/DIV. However, if the Probe option is set to 10X, the display will show 20 V/DIV, even if your signal really is 2 V/DIV. The Invert option inverts the signal.
3. VOLTS/DIV KNOB. This knob adjusts the volts per division on the display for CH1.
4. POSITION/CURSOR 2 KNOB. This knob moves the signal from CH2 up and down on the display.
5. MATH MENU BUTTON. This button displays the math menu of the oscilloscope. The (CH1 + CH2) function adds the signals of CH1 and CH2 and displays the result on the screen. (If CH2 is inverted, the two signals will be subtracted.)
6. CH2 MENU BUTTON. This button shows the menu for CH2. It also serves as a display switch so that the signal on CH2 can be turned on or off on the screen. The features of the menu are the same as for CH1.
7. VOLTS/DIV KNOB. This knob adjusts the volts per division on the display for CH2.

### Horizontal controls

These controls allow you to manually move the signal on the display from side to side as well as change the seconds per division (how much of the waveform is displayed horizontally).

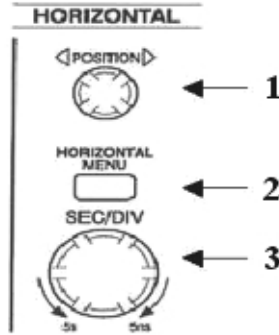

Figure 8. Horizontal Controls

1. POSITION 1 KNOB. This knob moves the signal to the right and left on the display.
2. HORIZONTAL MENU. Displays the menu for the horizontal display. You typically won't need to use this feature.
3. SEC/DIV KNOB. This knob allows you to change the scaling of the seconds per division on the x-axis of the display screen.

### Taking Measurements

The Measure button is located in the Menu panel (shown in Figure 8), which is located near the upper right corner of the display screen.

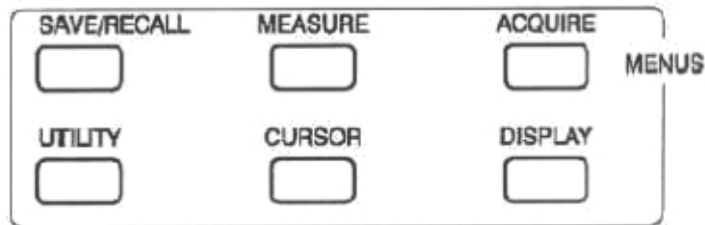

Figure 9. Menu Panel

When the measure button is pressed, a measurement menu and display appears on the right side of the screen, as shown in Figure 9.

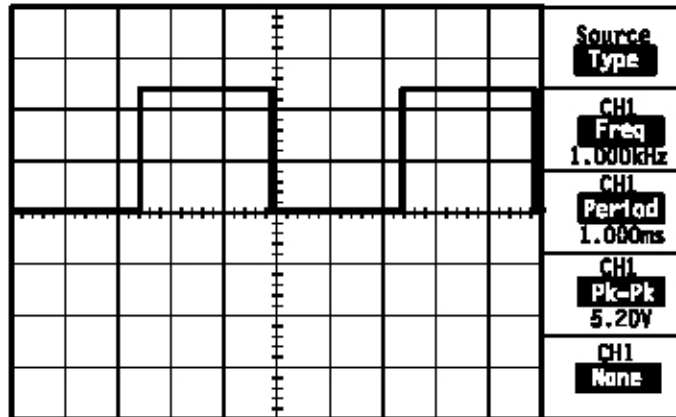

Figure 10. Measure Function Menu

### Measuring a signal

1. Press the **Measure** menu button. Press the top button next to the “Source/Type” until Source is highlighted.
2. Select the desired input channel to measure in the boxes below. While Source is highlighted, you can select CH1 or CH2 by pressing the button directly to the right of each measurement box.
3. Press the “Source/Type” button to highlight Type.
4. Change the type of measurement to display in the boxes below by pressing the button directly to the right of each. While Type is highlighted, you can select from the following measurements:
  - a. **Cyc RMS** – Displays true RMS measurement of one completed cycle of the waveform
  - b. **Mean** – Displays the arithmetic MEAN voltage over the entire record
  - c. **Period** – Displays the time for one cycle
  - d. **Pk-Pk** – Displays the peak-to-peak voltage, absolute difference between the maximum and minimum peaks of the entire waveform
  - e. **Freq** – Displays the frequency of the waveform

### Using Cursors

The cursor function is useful for manually measuring voltage amplitudes, or time difference between two points.

### Measuring Voltage

1. Press the **Cursor** button to display the Cursor Menu.
2. For the Type, select **Voltage**.
3. For the **Source**, select the channel of the waveform you’d like to measure.
4. Use the **CH1 Position/Cursor 1** knob to move the cursor to the point you’d like to measure.
5. Use the **CH2 Position/Cursor 2** knob to move the second cursor to the desired location.
6. The Delta value shows the difference between the two cursors.

### Measuring Rise Time

1. Adjust the **Sec/Div** knob to “zoom-in” on the rising edge of the waveform.
2. Adjust the **Volts/Div** knob to set the waveform amplitude to five divisions, peak to peak, as shown in Figure 10 below.
3. Use the Vertical **Position** knob to center the waveform with the centerline.
4. Press the **Cursor** button to display the Cursor Menu.
5. For the Type, select **Time**.
6. For the **Source**, select the channel of the waveform you’d like to measure.
7. Use the **CH1 Position/Cursor 1** knob to move the cursor to the point where the waveform crosses the second division line below the centerline. This is the 10% point of the waveform.
8. Use the **CH2 Position/Cursor 2** knob to move the second cursor to where the waveform crosses the second division line above the centerline. This is the 90% point of the waveform.
9. The Delta readout in the cursor menu is the rise time.

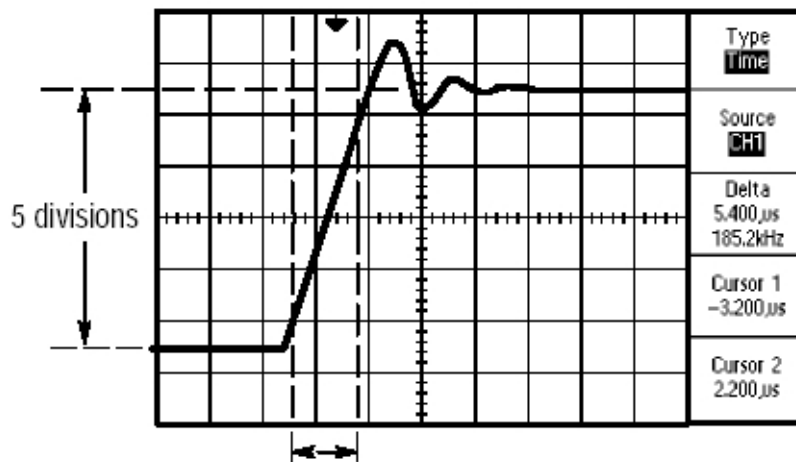
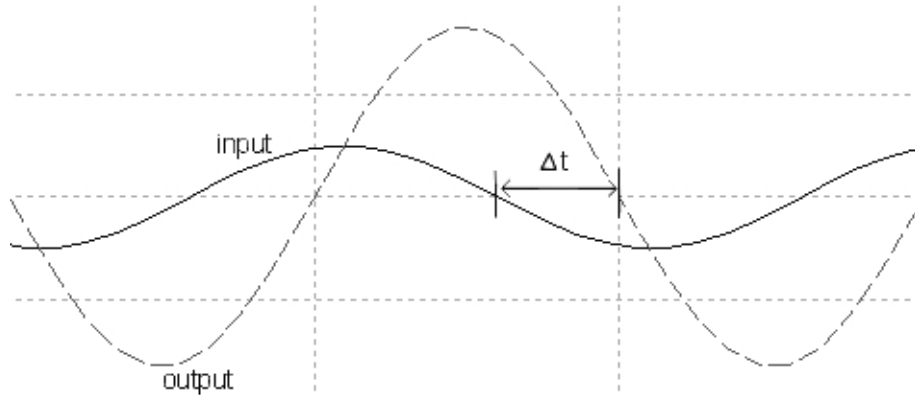

Figure 11. Measuring Rise Time

### Measuring Phase Difference

The phase difference is the time lag between the input and the output. See Figure 11, below.

1. Use the Vertical **Position** knobs for CH1 and CH2 to center both waveforms with the centerline of the scope display.
2. Press the **Cursor** button to display the Cursor Menu.
3. For the Type, select **Time**.
4. Use the **CH1 Position/Cursor 1** knob to move the cursor to the point where the input waveform crosses the centerline.
5. Use the **CH2 Position/Cursor 2** knob to move the second cursor to where the output waveform crosses the centerline.
6. The Delta readout in the cursor menu is the time difference,  $\Delta t$ . Calculate the phase difference =  $\Delta t * \text{frequency} * 180^\circ$



**Figure 12. Measuring Phase Difference**

### **Analyzing a Noisy Signal**

If a signal looks noisy on the display screen, try pressing the **Run/Stop** button, located near Autoset. This takes a snapshot of the digital signal displayed on the screen to allow for easier analyzing and measuring on the signal. Instead, you can try pressing the **Acquire** button, located in the menu panel, to open the Acquire menu. Then select **Average** to reduce the random noise in the signal for easier analysis.

### **Coupling**

Trigger coupling determines what part of the signal passes on to the trigger circuit. Coupling types include DC, AC, Noise Rejection, High Frequency Rejection, and Low Frequency Rejection. In this class, we will only use DC and AC coupling.

**DC.** DC coupling passes both AC and DC components.

**AC.** AC coupling blocks DC components.

## Breadboard

You will be using your breadboard to build and connect circuits. Many components can be directly plugged into the holes and jumper wires can be used to form interconnections between them. The holes in the vertical column to the right of the red line are connected (shorted) together, as are those in the column to the left of the blue line. (In Figure 12 below, these columns are also designated by + and – symbols.) On some breadboards, these two columns may not have the colored lines but still function in a similar manner, and are typically used for connecting power and ground rails. For the rest of the board, the holes are connected across horizontal rows. In the Figure below, the five holes in the top row (Row #1, Column a, b, c, d and e) are shorted. This means that if we apply a voltage or signal to one hole (say b1), the rest of the holes in the row (a1, c1, d1, e1) will have the same voltage. It is a general rule that where there is a gap on the face of the board, the holes are not connected. For example, in the Figure, a-e are connected together and, separately, f-j are connected together.

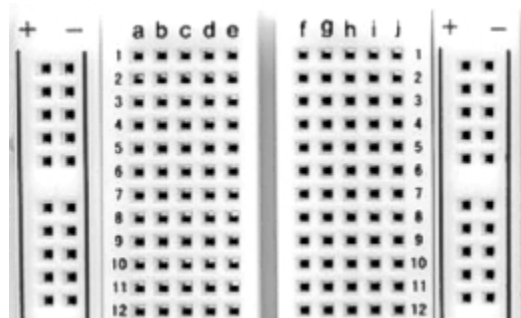

Figure 13. Breadboard Layout