

Op Amp Booster Designs

National Semiconductor
Application Note 272
September 1981



Op Amp Booster Designs

Although modern integrated circuit operational amplifiers ease linear circuit design, IC processing limits amplifier output power. Many applications, however, require substantially greater output voltage swing or current (or both) than IC amplifiers can deliver. In these situations an output "booster," or post amplifier, is required to achieve the needed voltage or current gain. Normally, this stage is placed within the feedback loop of the operational amplifier so that the low drift and stable gain characteristics of the amplifier are retained. Because the booster is a gain stage with its own inherent AC characteristics, the issues of phase shift, oscillation, and frequency response cannot be ignored if the booster and amplifier are to work well together. The design of booster stages which achieve power gain while maintaining good dynamic performance is a difficult challenge. The circuitry for boosters will change with the application's requirements, which can be very diverse. A typical current gain stage is shown in *Figure 1*.

200 mA CURRENT BOOSTER

The circuit of *Figure 1* boosts the LF356 unity gain inverter amplifier's output current to a ± 200 mA level while maintaining a full ± 12 V output swing. The LM334 current sources are used to bias complementary emitter-followers. The 200Ω resistors and D1-D4 diodes associated with the LM334s provide temperature compensation for the current sources, while the 20Ω resistor sets the current value at 3.5 mA. Q1 provides drive for positive LF356 output swings, while Q2 sinks current for negative amplifier outputs. Cross-over distortion is avoided by the D2-D3 diodes which compensate the V_{BE} s of Q1 and Q2. For best results, D2 and D3 would be thermally coupled to the TO-5 type heat sinks used for Q1 and Q2. Amplifier feedback is taken from the booster output and returned to the LF356 summing junction. D5 and D6 achieve short circuit protection for the output by shunting drive from Q1 or Q2 when output current exceeds

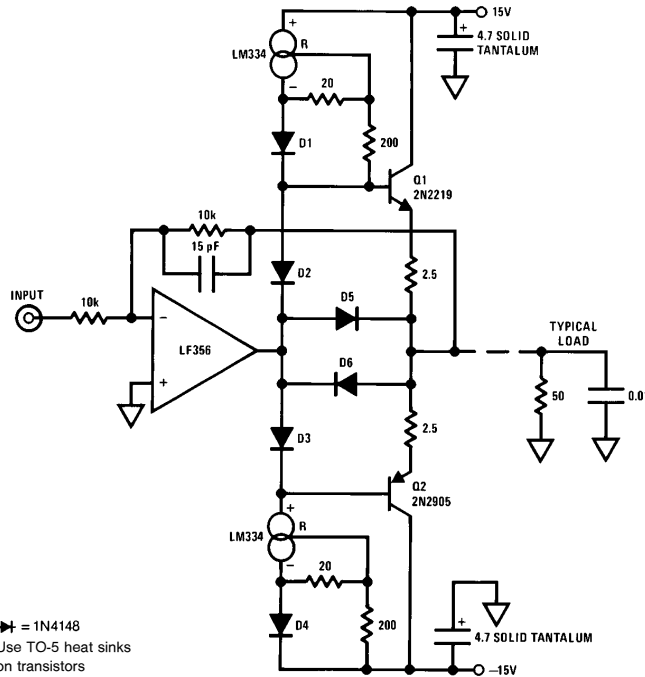

\rightarrow = 1N4148
 Use TO-5 heat sinks on transistors
 All capacitor values in μ F unless otherwise noted

FIGURE 1

TL/H/5630-1

AN-272

about 275 mA. This value is derived from the output 2.5Ω resistors value divided by the 0.7V drop across the diodes. The 15 pF-10k feedback values provide a roll-off above 2 MHz. *Figure 2* shows the circuit at work driving a 100 kHz 20 Vp-p sine wave into a 50Ω load paralleled by 10,000 pF/ Trace A is the input, while Trace B is the output. Despite the heavy load, response is clean below and quick with overall circuit distortion 0.05% (Trace C).

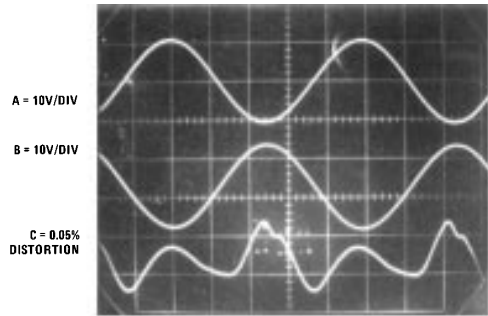
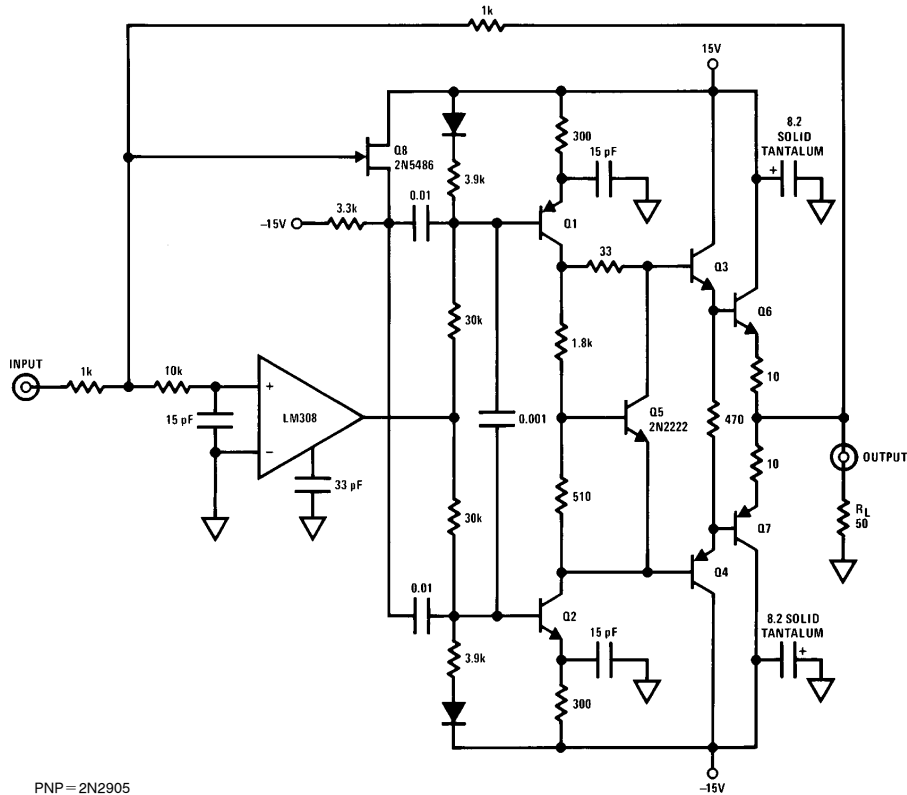

FIGURE 2

ULTRA HIGH SPEED FED-FORWARD CURRENT BOOSTER

The schematic of *Figure 3* features the same output specifications as the previous current booster, but provides much greater speed. The speed of the booster in *Figure 1* is limited by the response of the op amp which drives it. Because that booster resides in the op amp's feedback loop, it cannot go any faster than the op amp, even though it has inherently greater bandwidth. In *Figure 3* we employ a feed-forward network which allows AC signals to bypass the LM308 op amp and directly drive a very high bandwidth current boost stage. At DC and low frequencies the LM308 provides the signal path to the booster. In this fashion, a very high speed, high current output is achieved without sacrificing the DC stability of the op amp. The output stage is made up of the Q1 and Q2 current sources which bias complementary emitter-followers, Q3-Q6 and Q4-Q7. Because the stage inverts, feedback is returned to the non-inverting input of the LM308. The actual summing junction for the circuit is the meeting point of the 1k resistors and the 10k unit at the LM308. The 10k-15 pF combination prevents the LM308 from seeing high frequency inputs. Instead, these inputs are source-followed by the Q8 FET and fed directly to the output stage via the two 0.01 μF capacitors. The LM308, therefore, is used to maintain loop stability only at DC and low frequencies. Although this arrangement is substantially more complex than *Figure 1*, the result is a breathtaking



PNP = 2N2905
NPN = 2N2219 unless noted
TO-5 heat sinks for Q6-Q7

FIGURE 3

TL/H/5630-3

increase in speed. This boosted amplifier features a slew rate of 750V per microsecond, a full power bandwidth over 6 MHz and a 3 dB point beyond 11 MHz while retaining a $\pm 12V$, 200 mA output. *Figure 4* shows the amplifier-booster at work. Trace A is the input, while Trace B is the output. The booster drives a 10V pulse into 50 Ω , with rise and fall times inside 15 ns and clean settling characteristics.

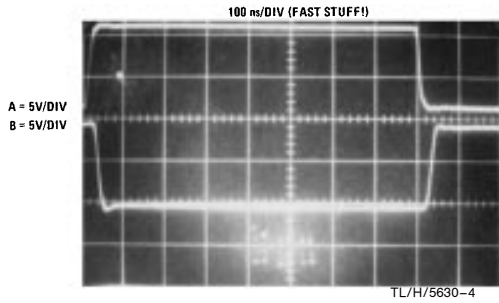

FIGURE 4

VOLTAGE-CURRENT BOOSTER

In many applications it is desirable to obtain voltage gain from a booster stage. Most monolithic amplifiers will only swing $\pm 12V$, although some types, such as the LM143, can swing $\pm 35V$. The circuit of *Figure 5* shows a simple way to effectively double the voltage swing across a load by stacking or "bridging" amplifier outputs. In the circuit shown, LF0002 current amplifiers are included in each LF412 output to provide current drive capability. Because one amplifier inverts and the other does not, the load sees 24V across

it for $\pm 12V$ swings from each amplifier. With the LH0002 current buffers, 24V can be placed across a 250 Ω load. Although this circuit is simple and no high voltage supplies are needed, it requires that the load float with respect to ground.

$\pm 120V$ SWING BOOSTER

In *Figure 6* the load does not have to float from ground to be driven at high voltage. This booster will drive a 2000 Ω load to $\pm 100V$ with good speed. In this circuit, voltage gain is

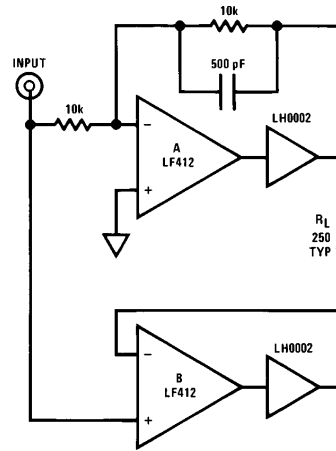

FIGURE 5

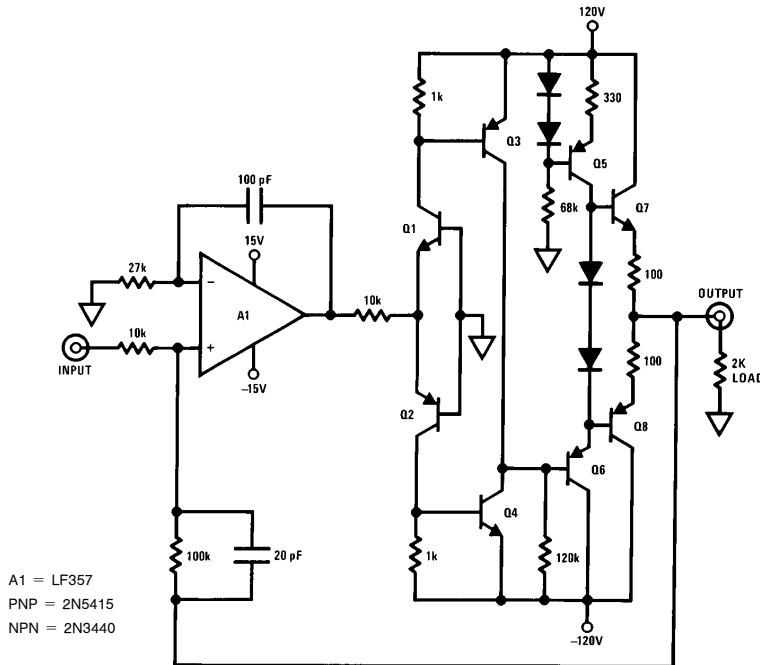

FIGURE 6

obtained from the complementary common base stage, Q1-Q2. Q3 and Q4 provide additional gain to the Q7-Q8 complementary emitter-follower output stage. Q5 and Q6 provide bias, and crossover distortion is minimized by the diodes in Q5's collector line. For $\pm 10V$ input signals, A1 must operate at a minimum gain of 10 to achieve a $\pm 100V$ swing at the output. In this case, 10k-100k feedback values are used for a gain of ten, and the 20 pF capacitor provides loop roll-off. Because the booster contains an inverting stage (Q3-Q4), overall feedback is returned to A1's positive input. Local AC feedback at A1's negative input provides circuit dynamic stability. With its ± 50 mA output, this booster yields currents as well as voltage gain. In many applications, such as CRT deflection plate driving, this current capability is not required. If this is the case, Q5 through Q8 and their associated components can be eliminated and the output and feedback taken directly from the Q3-Q4 collector line. Under these conditions, resistive output loading should not exceed 1 M Ω or significant crossover distortion will appear. Since deflection plates are a pure capacitive load, this is usually not a problem. Figure 7 shows the boosted amplifier driving a $\pm 100V$ square wave into a 2000 Ω load at 30 kHz.

HIGH CURRENT BOOSTER

High current loads are well served by the booster circuit of Figure 8. While this circuit does provide voltage gain, its ability to drive 3A of current into an 8 Ω load at 25V peak

makes it useful as a current booster. In this circuit, the LM391-80 driver chip and its associated power transistors are placed inside the LF411's feedback loop. The 5 pF capacitor at pin 3 of the LM391-80 sets the booster bandwidth well past 250 kHz. The 100k-10k feedback resistors set a gain of ten, and the 100 pF feedback capacitor rolls off the loop gain at 100 kHz to insure stability for the amplifier-booster combination. The 2.7 Ω -0.1 μ F damper network and the 4 μ H inductor prevent oscillations. The zero signal current of the output stage is set with the 10k potentiometer (pins 6-7 at the LM391) while a DVM is monitored for 10 mV across the 0.22 Ω output resistors.

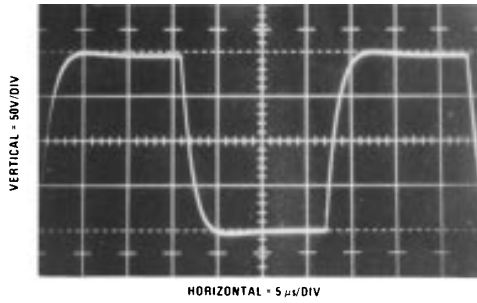

FIGURE 7

TL/H/5630-6

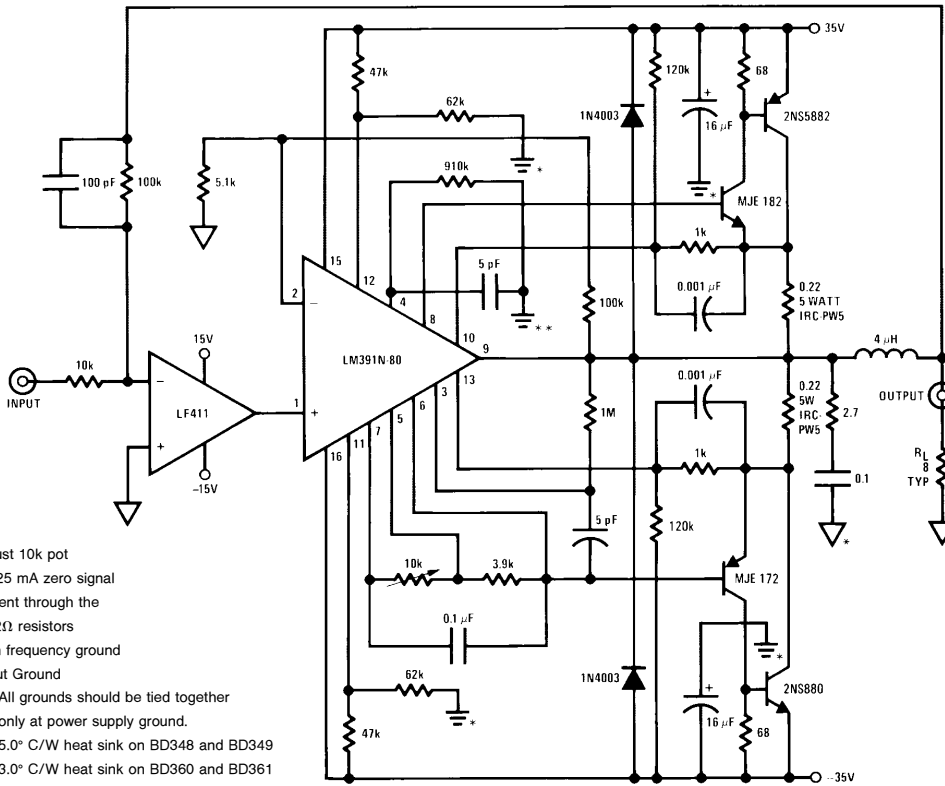

FIGURE 8

TL/H/5630-7

INDESTRUCTIBLE, FLOATING OUTPUT BOOSTER

Figure 9 shows how a high quality audio amplifier can be used as a current-voltage booster for AC signals. The audio amplifier, specified as the booster, is a venerable favorite in research labs, due to its transformer isolated output and clean response. The LF356 op amp's loop is closed locally at a DC gain of 100, and rolled off at 50 kHz by the 200 pF capacitor. The audio amplifier booster's output is fed back via the 100k resistor for an overall AC gain of 100 with respect to the booster amplifier output. The arrangement is ideal for laboratory use because the vacuum tube driven transformer isolated output is extremely forgiving and al-

most indestructible. AC variable frequency power supplies, shaker table drives, motors and gyro drives, as well as other difficult inductive and active loads, can be powered by this booster. Power output is 75W into 4Ω-16Ω, although loads of 1Ω can be driven at reduced power output.

1000V-300 mA BOOSTER

Figure 10 diagrams a very high voltage, high current booster which will allow an op amp to control up to 300W for positive outputs up to a staggering 1000V. This performance is achieved without sacrificing efficiency because this booster, in contrast to all the others shown, operates in a switching

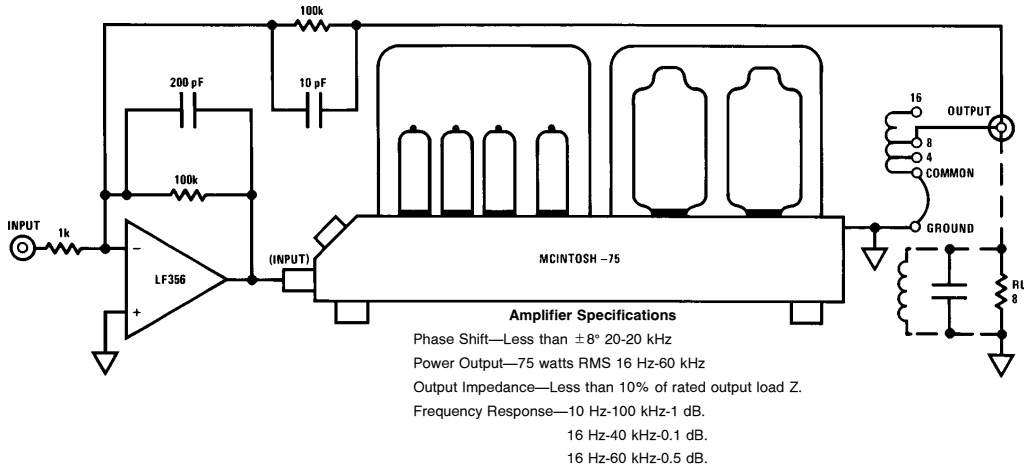

FIGURE 9

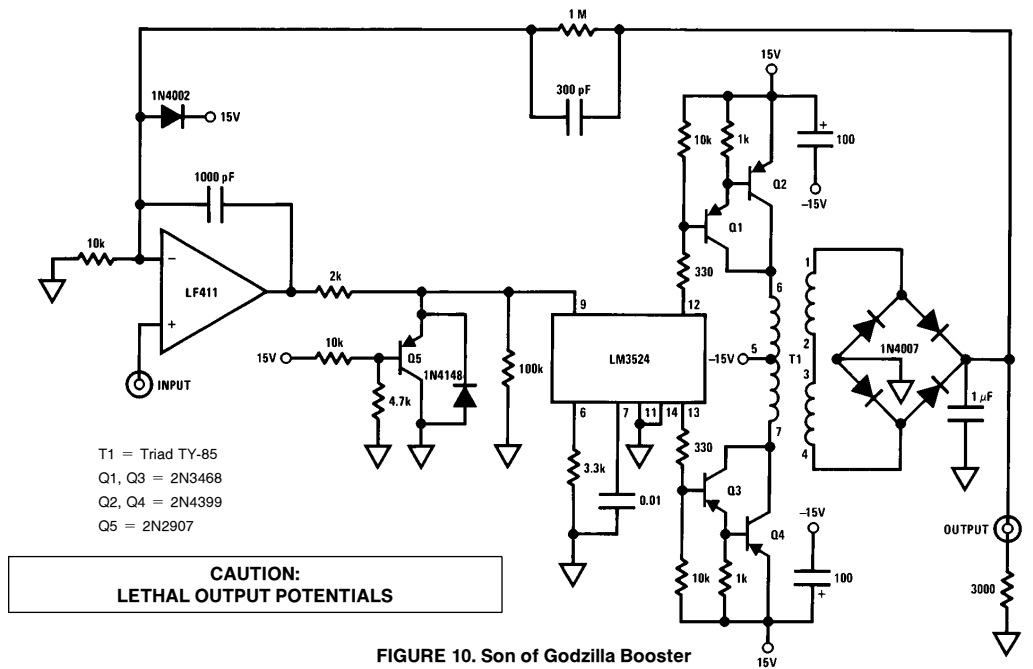

FIGURE 10. Son of Godzilla Booster

TL/H/5630-8

mode. In addition, this booster runs off $\pm 15V$ supplies and has the highly desirable property of *not* requiring a high voltage power supply to achieve its high potential outputs. The high voltage required for the output is directly generated by a switching DC-DC converter which forms an integral part of the booster. The LM3524 switching regulator chip is used to pulse width modulate the transistors which provide switched 20 kHz drive to the TY-85 step-up transformer. The transformer's rectified and filtered output is fed back to the LF411, which controls the input to the LM3524 switching regulator. In this manner, the high voltage booster, although operating switched mode, is controlled by the op amp's feedback action in a similar fashion to all the other designs. Q5 and the diode act as clamps to prevent the LF411's output swing from damaging the LM3524's 4V input on start-up. The diode at the LF411 swing junction prevents high voltage transients coupled through the feedback capacitor from destroying the amplifier. The 1 M Ω -10k feedback resistors set the gain of the amplifier at 100 so that a 10V input will give a 1000V output. Although the 20 kHz torroid switching rate places an upper limit on how fast information can be transmitted around the loop, the 1 μ F filter capacitor at the circuit output restricts the bandwidth. For the design shown, full power sine wave output frequency is 55Hz. Figure 11 shows the response of the boosted LF411 when a 10V pulse (Trace A) is applied to the circuit input. The output (Trace B) goes to 1000V in about 1 ms, while fall time is about 10 ms because of capacitor discharge

time. During the output pulse's rise time the booster is slew rate limited and the switching action of the torroid is just visible in the leading edge of the pulse.

The reader is advised that the construction, testing and use of this circuit must be approached with the greatest care. The output potentials produced are many times above the level which will kill. Repeating, the output of this circuit is lethal.

300V OUTPUT BOOSTER

The circuit of Figure 12 is another high voltage booster, but will only provide 10 mA of output current. This positive-output-only circuit will drive 350V into a 30k load, and is almost

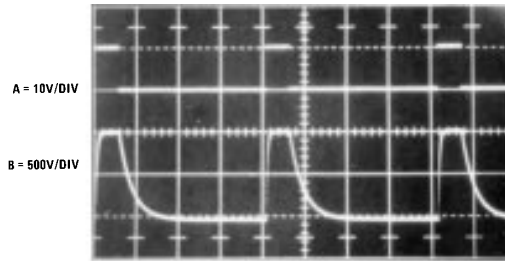

HORIZONTAL = 10 ms/DIV TL/H/5630-9

FIGURE 11

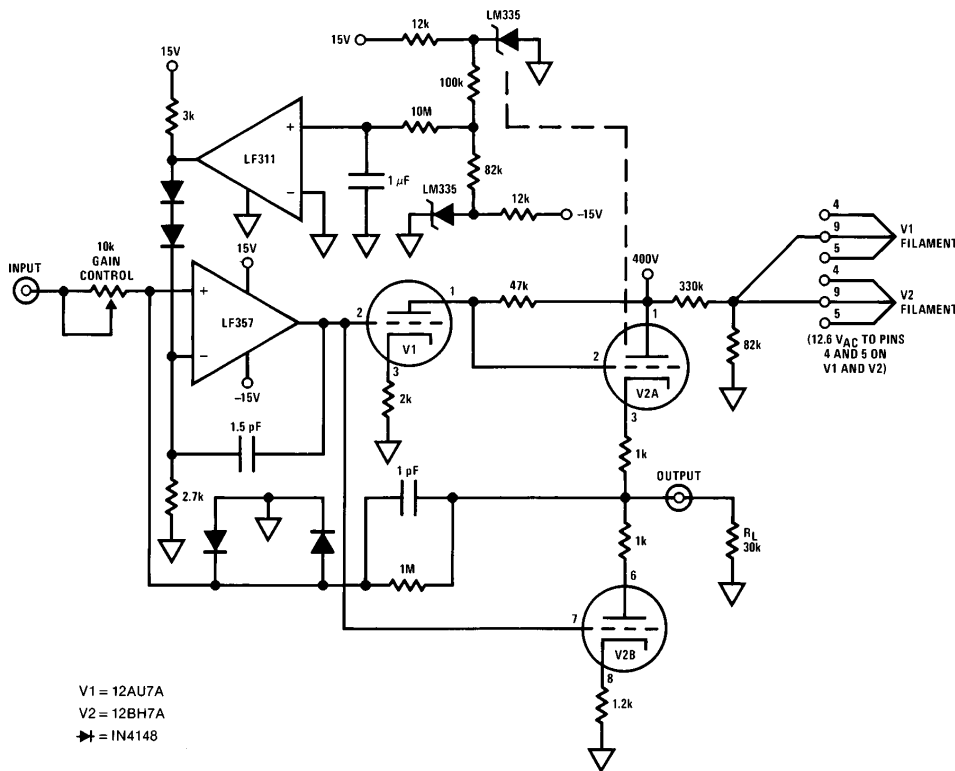

FIGURE 12

TL/H/5630-10

immune to load shorts and reverse voltages. A solid state output requires substantial protection against these conditions. Although the circuit shown has a 350V limit, tubes (remember them?) with higher plate voltage ratings can extend the output capacity to several kilovolts. In this circuit, our thermionic friends are arranged in a common cathode (V2B) loaded-cathode-follower (V2A) output, driven from a common cathode gain stage (V1). The booster output is fed back to the LF357 via the 1 MΩ resistor. Local feedback is used to stabilize the LF357, while the pF-1 MΩ pair rolls off the loop at 1 MHz. Because the V1 stage inverts, the feedback summing junction is placed at the LF357 positive input. The parallel diodes at the summing junction prevent high voltage from destroying the amplifier during circuit start-up and slew rate limiting. Tubes are inherently much more tolerant of load shorts and reverse voltages than transistors, and are much easier to protect. In this circuit, an LM335 temperature sensor is in contact with V2. This

sensor's output is compared with another LM335 which senses ambient temperature. Under normal operating conditions, V2 operates about 45°C above ambient and the "+" input of the LF311 is about -100 mV, causing its output to be low. When a load fault occurs, V2's plate dissipation increases, causing its associated LM335's output to rise with respect to ambient temperature. This forces the LF311's output high, which makes the LF357 output go low, shutting down the output stage. Adequate hysteresis is provided by the thermal time constant of V2 and the 10 MΩ-1 μF delay in the LF311 input line. Figure 13 shows the response of this amplifier booster at a gain of about 25. With a 15V input pulse (Trace A), the output (Trace B) goes to 350V in 1 μs, and settles within 5 μs. The falling edge slews equally fast and settling occurs within 4 μs.

Figure 14 is a table which summarizes the information in this article and will help you to pick the right booster for your particular application.

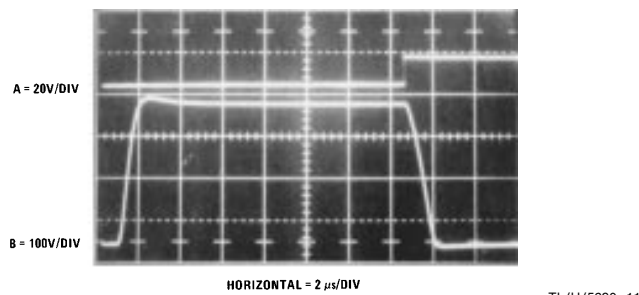

FIGURE 13

Figure	Voltage Gain	Current Gain	Bandwidth	Comments
1	No	Yes—200 mA	Depends on op amp. Typical 1 MHz	Full "+" and "-" output swing. Stable into 50Ω-10,000 pF load. Inverting or non-inverting operation. Simple.
3	No	Yes—200 mA	Full output to 5 MHz-3dB. Point at 11 MHz.	Ultra fast. 750V/μs. Full bipolar output. Inverting operation only.
5	Yes—24V swing	No	Depends on op amp.	Requires that load float from ground.
6	Yes—± 100V	Yes—50 mA	50 kHz typical.	Full "+" and "-" output swing. Allows inverting or non-inverting operation. Simplified version ideal for CRT deflection plate driving. More complex version drives full 200V swing into 2 kΩ and 1000 pF.
8	Yes—± 30V	Yes—3A	50 kHz	Full "+" and "-" output swing. Allows inverting or non-inverting operation.
9	Yes—70V swing	Yes—3A	100 kHz	Output extremely rugged. Well suited for driving difficult loads in lab. Set-ups. Full bipolar output. AC only.
10	Yes—1000V	Yes—300 mA	50 Hz	High voltage at high current. Switched mode operation allows operation from ± 15V supplies with good efficiency. Limited bandwidth with asymmetrical slewing. Positive outputs only.
12	Yes—350V	No	500 kHz	Output very rugged. Good speed. Positive outputs only.

FIGURE 14

LIFE SUPPORT POLICY

NATIONAL'S PRODUCTS ARE NOT AUTHORIZED FOR USE AS CRITICAL COMPONENTS IN LIFE SUPPORT DEVICES OR SYSTEMS WITHOUT THE EXPRESS WRITTEN APPROVAL OF THE PRESIDENT OF NATIONAL SEMICONDUCTOR CORPORATION. As used herein:

1. Life support devices or systems are devices or systems which, (a) are intended for surgical implant into the body, or (b) support or sustain life, and whose failure to perform, when properly used in accordance with instructions for use provided in the labeling, can be reasonably expected to result in a significant injury to the user.
2. A critical component is any component of a life support device or system whose failure to perform can be reasonably expected to cause the failure of the life support device or system, or to affect its safety or effectiveness.



National Semiconductor Corporation
 1111 West Bardin Road
 Arlington, TX 76017
 Tel: 1(800) 272-9959
 Fax: 1(800) 737-7018

National Semiconductor Europe
 Fax: (+49) 0-180-530 85 86
 Email: onjwge@tevm2.nsc.com
 Deutsch Tel: (+49) 0-180-530 85 85
 English Tel: (+49) 0-180-532 78 32
 Français Tel: (+49) 0-180-532 93 58
 Italiano Tel: (+49) 0-180-534 16 80

National Semiconductor Hong Kong Ltd.
 19th Floor, Straight Block,
 Ocean Centre, 5 Canton Rd.
 Tsimshatsui, Kowloon
 Hong Kong
 Tel: (852) 2737-1600
 Fax: (852) 2736-9960

National Semiconductor Japan Ltd.
 Tel: 81-043-299-2309
 Fax: 81-043-299-2408

National does not assume any responsibility for use of any circuitry described, no circuit patent licenses are implied and National reserves the right at any time without notice to change said circuitry and specifications.