



## ECE145B/ECE218B Mixer Lectures

1. Introduction to mixer operation and specifications
2. Single and double balanced diode and FET mixers
3. Active mixers - Gilbert multiplier
4. Image reject mixers

1

### Reading list:

1. P. Gray and R. Meyer, *Analysis and Design of Analog Integrated Circuits*, Third Ed., J. Wiley, 1993. Section 10.3
2. M. McWhorter, D. Scherer, H. Swain, EE344 High Frequency Laboratory, Stanford Univ., 1995. Chapter 6.
3. B. Razavi, *RF Microelectronics*, Prentice Hall, 1998. Sect. 5.2.3. pp. 138 – 146.
3. B. Razavi, *RF Microelectronics*, Prentice Hall, 1998. Sect. 5.2.3.
4. T. H. Lee, *The Design of CMOS Radio Frequency Integrated Circuits*, Cambridge Univ. Press, 1998. Chap. 12.



---

## Basic engineering problem:

*Choosing the right mixer for the task...*



### Learning Objectives:

- Understand operating principles of the mixer
- What makes a good mixer?
- Choices: Nonlinear/switching mode; single/double balance; active/passive
- Specify performance: Gain, NF,  $P_{1dB}$ , TOI, SFDR, isolation, image rejection
- Review some mixer design examples

2

There are many different mixer circuit topologies and implementations that are suitable for use in receiver and transmitter systems. How do you select the best one for a particular application? Why does the choice depend on the application and technology available?



## Why study mixers?

- Receivers
  - up or down conversion
  - demodulation of SC SSB or SC DSB
  - input must support large dynamic range
  - AGC
- Transmitters
  - up conversion
  - modulation: amplitude and phase
  - input has optimum signal level for high performance

3

Mixers have a wide variety of applications in communication systems.

The superheterodyne receiver architecture often has several frequency translation stages (IF frequencies) to optimize image rejection, selectivity, and dynamic range. Direct conversion receiver architectures such as used in pagers use mixers at the input to both downconvert and demodulate the digital information. Mixers are thus widely used in the analog/RF front end of receivers. In these applications, often the mixer must be designed to handle a very wide dynamic range of signal powers at the input.

The mixer can be used for demodulation, although the trend is to digitize following a low IF frequency and implement the demodulation function digitally. They can also be used as analog multipliers to provide gain control. In this application, one input is a DC or slowly varying RSSI signal which when multiplied by the RF/IF signal will control the degree of gain or attenuation.

In transmitter applications, the mixer is often used for upconversion or modulation. In this application, the input signal level can be selected to optimize the overall signal-to-noise ratio at the output.



## Mixer operating mechanisms

- Nonlinear transfer function
  - use device nonlinearities creatively!
  - useful at mm-wave frequencies
- Switching or sampling
  - a time-varying process
  - preferred; fewer spurs

4

High performance RF mixers use nonlinear characteristics to generate the multiplication. Thus, they also generate lots of undesired output frequencies.

Three techniques have proven to be effective in the implementation of mixers with high dynamic range:

1. Use a device that has a known and controlled nonlinearity.
2. Switch the RF signal path on and off at the LO frequency.
3. Sample the RF signal with a sample-hold function at the LO frequency.

The nonlinear mixer can be applicable at any frequency where the device presents a known nonlinearity. It is the only approach available at the upper mm-wave frequencies. When frequencies are low enough that good switches can be built, the switching mixer mode is preferred because it generates fewer spurs. In some cases, sampling has been substituted for switching.



## Nonlinear mixer operation

Any diode or transistor will exhibit nonlinearity in its transfer characteristic at sufficiently high signal levels.

$$V_o(t) = I_s (a_1 V_D + a_2 V_D^2 + \dots) R_L$$

second-order product term

5

We see that our output may contain a DC term, RF and LO feedthrough, and terms at all harmonics of the RF and LO frequencies. Only the second-order product term produces the desired output. Let's suppose that  $V_R$  and  $V_L$  are the fraction of  $V_{RF}$  and  $V_{LO}$  that appear across the nonlinear device (possibly a diode).

$$a_2 V_D^2 = a_2 \left[ V_R^2 \sin^2(\omega_R t) + V_L^2 \sin^2(\omega_L t) + 2V_R V_L \sin(\omega_R t) \sin(\omega_L t) \right]$$

The product term produces the desired mixer output:

$$V_R V_L [\cos(\omega_R - \omega_L)t - \cos(\omega_R + \omega_L)t]$$

DC and second harmonic terms are also present. Recalling

$$V_R^2 \sin^2(\omega_R t) = V_R^2 (1 - \cos 2\omega_R t)$$

If the application is frequency multiplication rather than mixing, the harmonic term can be useful. The DC term is proportional to RF input power, so can be used as a power meter.

In addition, when  $v_{RF}$  consists of multiple carriers, the power series also will produce cross-products that make the desired output products dependent on the amplitude of other inputs. Spurious output signal strengths can be decreased when devices that are primarily square-law, such as FETs with longer gate lengths, are used in place of diodes or bipolar transistors.



## Unbalanced diode mixer output

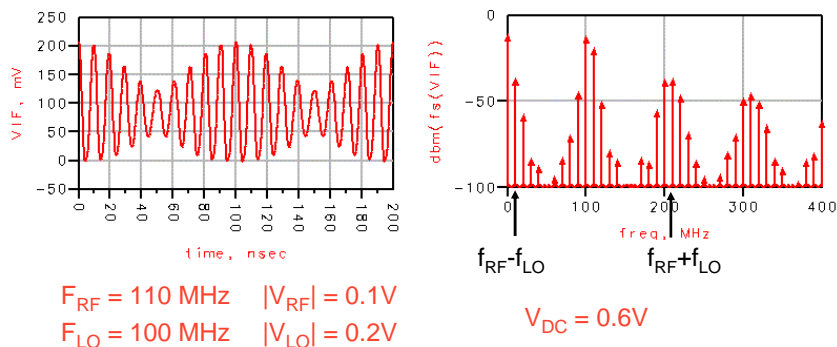

6

We can see that there are a lot of spurious outputs generated. Ideally, we would like to see outputs only at 10 MHz and 210 MHz. So, we prefer the switching type mixer when the RF and LO frequencies are low enough that we can make decent switches. This takes us up through much of the mm-wave spectrum.

[See ADS example file diode1.dsn]

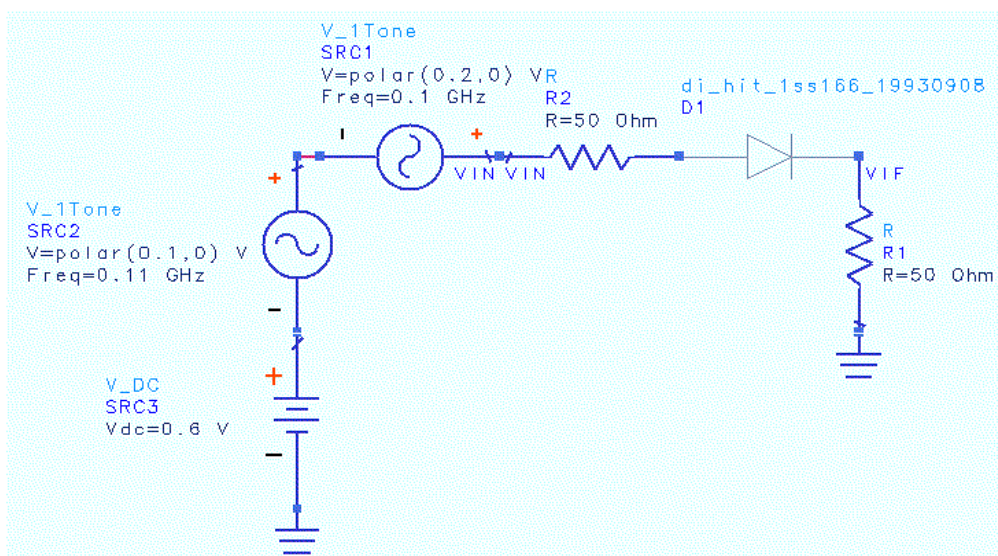



## Switching or sampling mixers

- Let  $V_{IN}(t) = V_R \cos(\omega_{RF}t)$
- Multiply by the LO switching function  $T(t)$

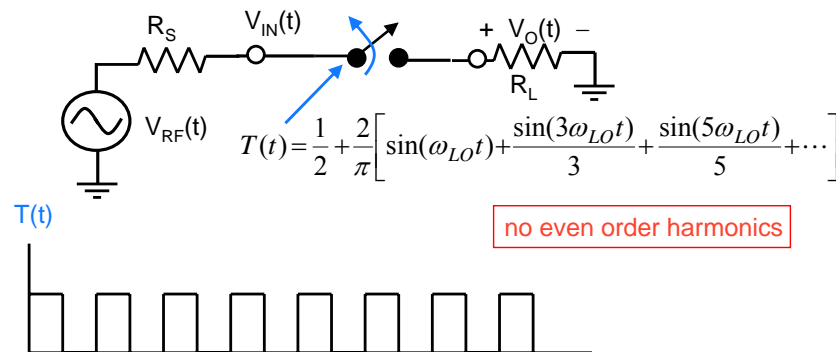

7

This simple switch is operated by the LO. If the LO is a square wave with 50% duty cycle, it is easily represented by its Fourier Series. The symmetry causes the even-order harmonics to drop out of the LO spectrum. When multiplied by a single frequency cosine at  $\omega_{RF}$  the desired sum and difference outputs will be obtained as shown in the next slide. Note that everything is single-ended; there is no balancing on this design.

There will be harmonics of the LO present at  $3\omega_{LO}$ ,  $5\omega_{LO}$ , etc. that will also mix to produce outputs called “*spurs*” (an abbreviation for spurious signals). These harmonics also convert broadband noise that is generated internal to the mixer (or that is allowed into the mixer input in the absence of a preselection filter) into the IF output band.

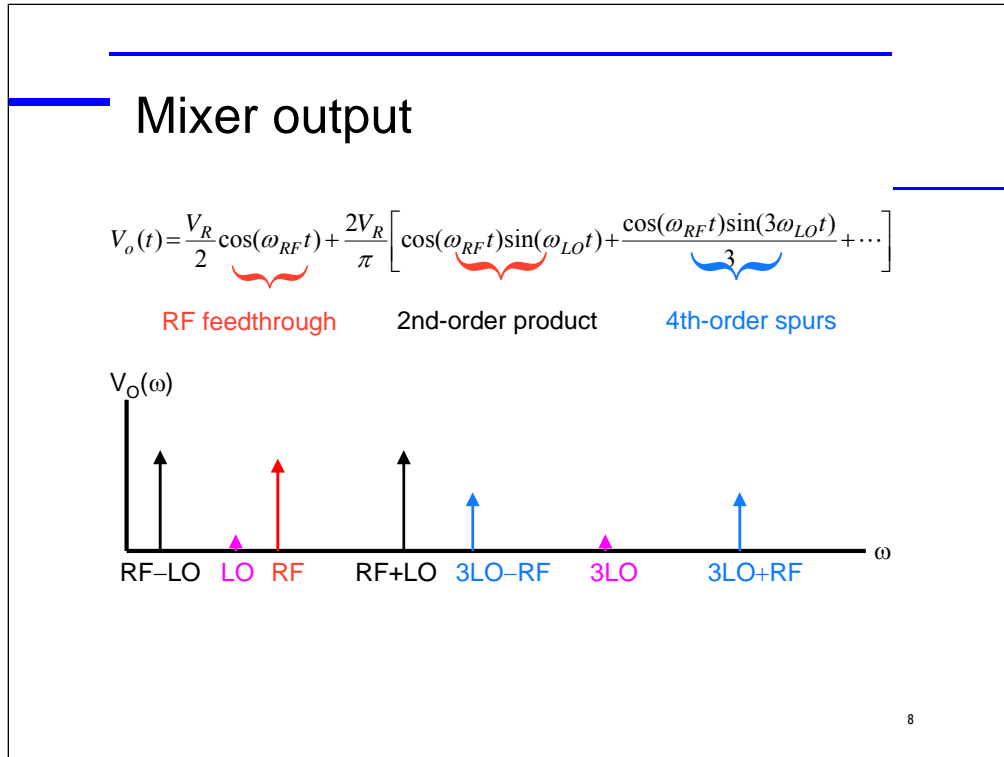

The product of  $V_{RF}(t)T(t)$  produces the desired output frequencies at

$$\omega_{RF} - \omega_{LO} \text{ and } \omega_{RF} + \omega_{LO} \text{ from the second order product.}$$

Odd harmonics of the LO frequency are also present since we have a square wave LO switching signal. These produce spurious 4th, 6th, ... order products with outputs at

$$n\omega_{LO} - \omega_{RF} \text{ and } n\omega_{LO} + \omega_{RF} \text{ where } n \text{ is odd.}$$

We also get *RF feedthrough* directly to the output.

None of the LO signal should appear in the output if the mixer behaves according to this equation. But, if there is a DC offset on the RF input, there will be a LO frequency component in the output as well. This requirement is not unusual, since many mixer implementations require some bias current which leads to a DC offset on the input.

**EXERCISE 1:** Use the diode in the nonlinear diode mixer simulation as a switch. Put a square wave LO in series with the RF generator and simulate the output spectrum using transient analysis. (solution in ADS file ex1)

[See ADS example files **swmix2.dsn** and **diode1.dsn**]





## Conversion gain or loss

- Generally expressed as a voltage gain or as a transducer power gain

$$A_V = \frac{V_{IF}}{V_{IN}}$$

$$ConvGain = \frac{\text{Output power at } F_{IF}}{\text{RF available input power}} = \left( \frac{\frac{v_{IF}^2}{2R_L}}{\frac{v_{RF}^2}{8R_S}} \right)$$

9

*Conversion gain* is usually defined as the ratio of the IF output power to the available RF source power. So we can be compatible with ADS output format, in these equations, the voltages are amplitudes, not RMS. If the source and load impedances are different, the power gain must account for this as shown. Voltage gains are also useful, especially in RFIC implementations of mixers.

$$A_v = \frac{2}{\pi} \cos(\omega_{RF}t) \sin(\omega_{LO}t) = \frac{1}{\pi} \{ \sin[(\omega_{RF} - \omega_{LO})t] + \sin[(\omega_{RF} + \omega_{LO})t] \}$$

$$CG = \frac{1}{\pi^2} = 0.1 \quad \text{or } -10dB$$

We see that the simple switching mixer has low conversion gain because the voltage gain  $A_V$  is only  $1/\pi$ . Also, the RF feedthrough problem and in most instances, an LO feedthrough problem exist. All of these deficiencies can be improved by the use of balanced topologies which provide some cancellation of RF and LO signals as well as increasing conversion gain.

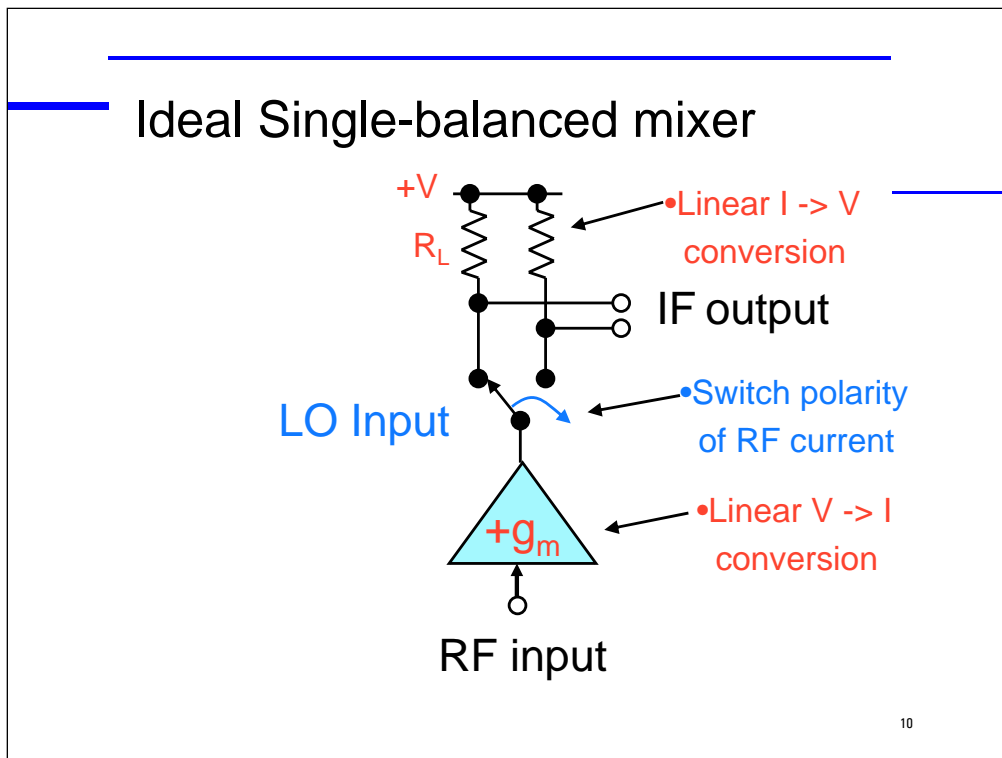

The RF feedthrough can be eliminated by using a differential IF output and a polarity reversing LO switch.

*Active or passive implementations* can be used for the mixer. Each has its advantages and disadvantages. The passive implementations using diodes as nonlinear elements or switches or FETs as passive switches always exhibit conversion loss rather than gain. This can impact the overall system noise performance, so if noise is critical, an LNA is usually added before the mixer.

The polarity reversing LO switching function is shown in the next slide.



## LO Switching Function T(t)

$$T_1(t) = \frac{1}{2} + \frac{2}{\pi} \left[ \sin(\omega_{LO}t) + \frac{1}{3} \sin(3\omega_{LO}t) + \dots \right]$$

$$T_2(t) = -\frac{1}{2} + \frac{2}{\pi} \left[ \sin(\omega_{LO}t) + \frac{1}{3} \sin(3\omega_{LO}t) + \dots \right]$$

SUM OF SWITCHING FUNCTIONS

$T_1(t)$

$T_2(t)$

$T(t) = T_1(t) + T_2(t)$

11

When added together, the DC terms (1/2 & -1/2) cancel. The DC term was responsible for the RF feedthrough in the unbalanced mixer since the  $\cos(\omega_{RF}t)$  term was multiplied only by  $T_1(t)$ .

$$V_{IF}(t) = g_m R_L V_R \cos(\omega_{RF}t) \frac{4}{\pi} \left[ \sin(\omega_{LO}t) + \frac{1}{3} \sin(3\omega_{LO}t) + \frac{1}{5} \sin(5\omega_{LO}t) + \dots \right]$$

Second-order term:

$$\frac{2g_m R_L V_R}{\pi} \left[ \sin(\omega_{RF} + \omega_{LO})t + \sin(\omega_{RF} - \omega_{LO})t \right]$$

Here we see that the ideal conversion gain  $(V_{IF}/V_R)^2 = (2/\pi)^2$  is 6 dB greater than for the unbalanced design (if  $g_m R_L = 1$ ).



## LO Feedthrough

$$\begin{aligned}
 V_{IF}(t) &= R_L [I_{DC} + g_m V_R \cos(\omega_{RF} t)] \times \\
 &\quad \frac{4}{\pi} \left[ \sin(\omega_{LO} t) + \frac{1}{3} \sin(3\omega_{LO} t) + \frac{1}{5} \sin(5\omega_{LO} t) + \dots \right] \\
 &= \frac{4R_L}{\pi} \{ I_{DC} \sin(\omega_{LO} t) + \leftarrow \\
 &\quad \frac{1}{2} g_m V_R [\sin(\omega_{RF} + \omega_{LO})t + \sin(\omega_{RF} - \omega_{LO})t] \}
 \end{aligned}$$

12

But, we can still get LO feedthrough if we take a single-ended output or if there is a DC current in the signal path. There is often DC present since the output of the transconductance amplifier will have a DC current component. This current shows up as a differential output.



## Output spectrum: SB mixer

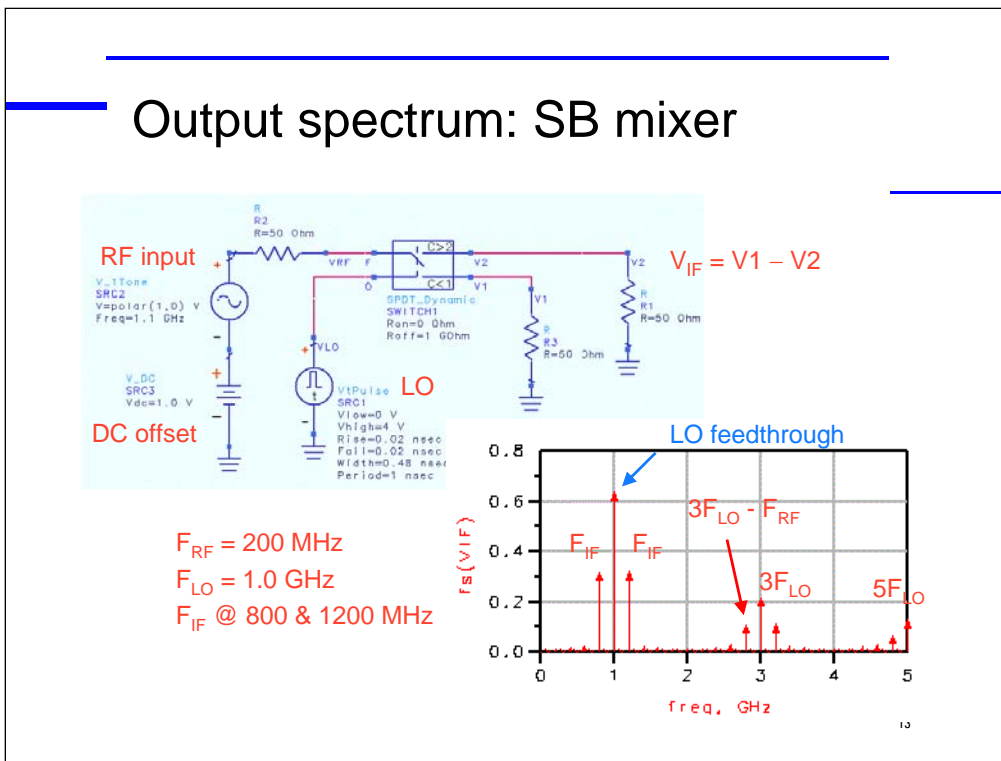

As you can see, the output spectrum of the single-balanced switching mixer is much less cluttered than the nonlinear mixer spectrum. This was simulated with transient analysis using an ideal switch. The behavioral switch model has an on-threshold of 2V and an off-threshold of 1V. The LO was generated with a 4V pulse function and the duty cycle was set to 50%. The output is taken differentially as  $V_{IF} = V1 - V2$ . Note the strong LO feedthrough component in the output. This is present because of the DC offset on the RF input which produces a differential LO voltage component in the output.

[See ADS example file `swmixer1.dsn`]

**EXERCISE 3:** Set the DC offset voltage to 0 and resimulate. Observe that the LO feedthrough is gone. Compare  $V1$  and  $V_{IF}$  vs time with and without the DC offset. Use markers to measure the IF output power and calculate the conversion gain. (solution in ADS file ex3)

This LO component is highly undesirable because it could desensitize a mixer postamplifier stage if the amplification occurs before IF filtering. Eliminating the LO component when a DC current is present requires *double-balancing*.

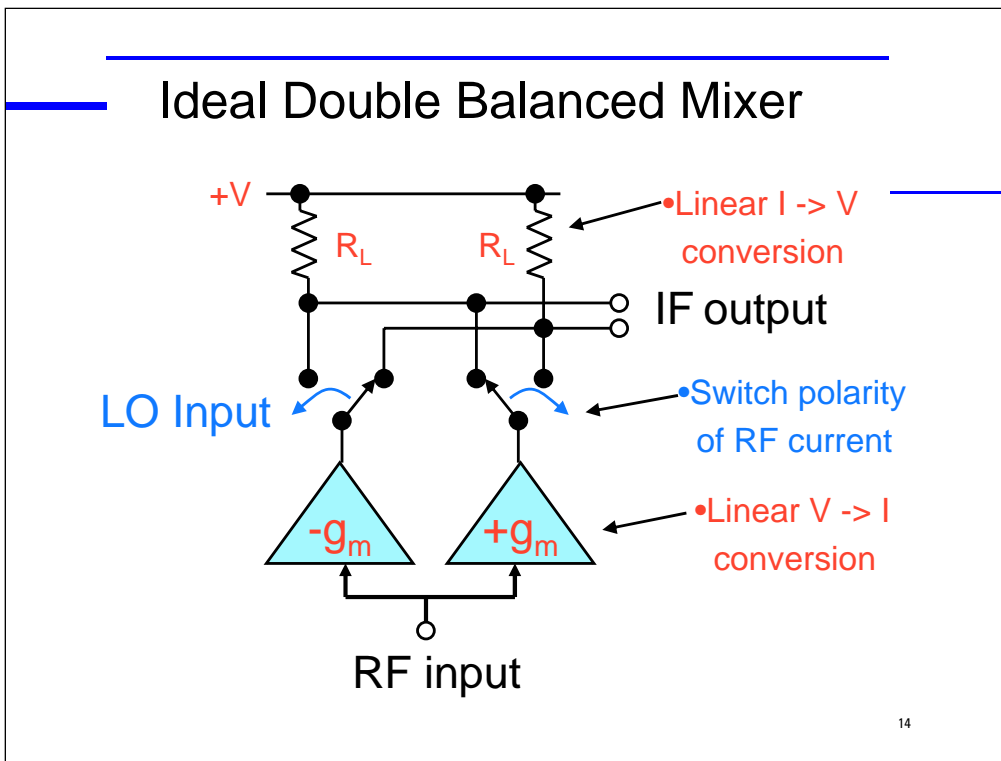

An ideal double balanced mixer consists of a switch driven by the local oscillator that reverses the polarity of the RF input at the LO frequency[1] and a differential transconductance amplifier stage. The polarity reversing switch and differential IF cancels any output at the RF input frequency since the DC term cancels as was the case for the single balanced design. The double LO switch cancels out any LO frequency component, even with currents in the RF to IF path. The LO is typically suppressed by 50 or 60 dB if the components are well matched and balanced.

An IF balun, either active (a differential amplifier) or passive (a transformer or hybrid), is often used, however, so that the conversion gain will be maximized.

To get the highest performance from the mixer we must make the RF to IF path as linear as possible and minimize the switching time of the LO switch. The ideal mixer above would not be troubled by intermodulation distortion (IMD) at the high end of the operating signal range since the ideal transconductors and resistors are linear and the switches are ideal.



## Double-balanced mixer

Two single-balanced mixers – difference cancels LO feedthrough

$$V_O = R_L [I_{DC} + I_R \cos(\omega_{RF} t)] \frac{4}{\pi} \left[ \sin(\omega_{LO} t) + \frac{1}{3} \sin(3\omega_{LO} t) + \dots \right] -$$

$$R_L [I_{DC} - I_R \cos(\omega_{RF} t)] \frac{4}{\pi} \left[ \sin(\omega_{LO} t) + \frac{1}{3} \sin(3\omega_{LO} t) + \dots \right]$$

From - gm side of mixer (desired output adds)

15

Single balancing got rid of the RF feedthrough which was caused by the average DC value of the switching function. Double balancing removes the LO feedthrough as well, since the DC term cancels.

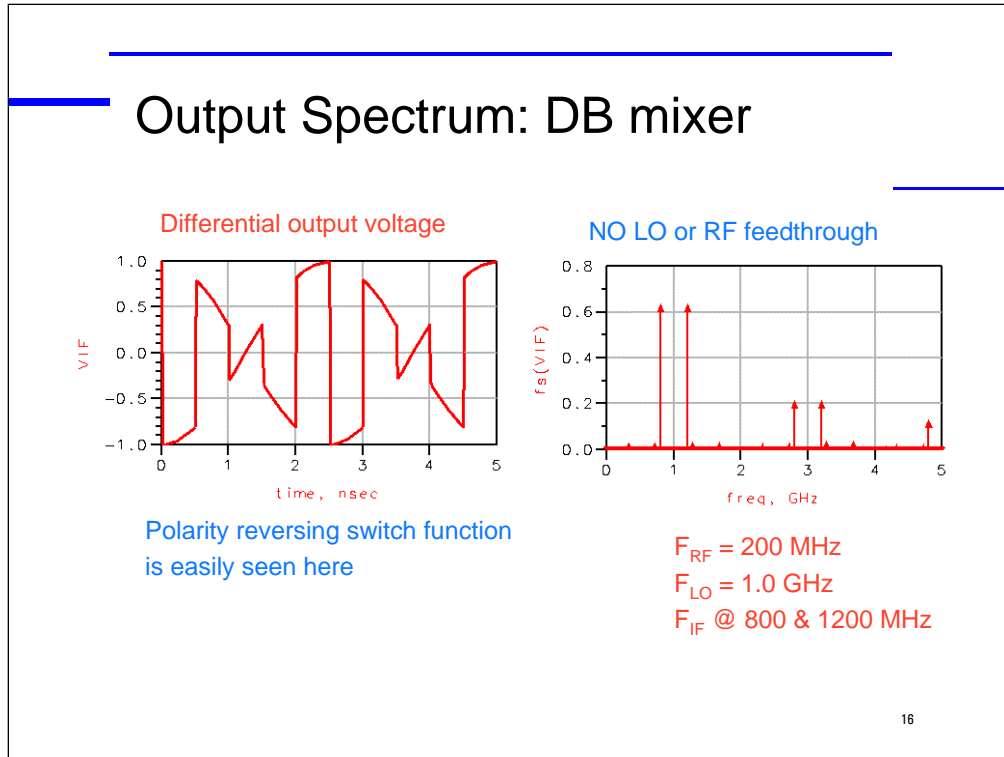

The differential output voltage and frequency spectrum are simulated using a transient analysis in ADS. The polarity switching action can be clearly seen in the output voltage. There is no LO or RF feedthrough in this ideal DB mixer, even with a DC current in the signal path.

**[See ADS example file: swmixer3.dsn]**

In real mixers, there is always some imbalance. Transistors and baluns are never perfectly matched or balanced. These nonidealities will produce some LO to IF or RF to IF feedthrough (thus, isolation is not perfect). This is usually specified in terms of a power ratio relative to the desired IF output power: dBc

Secondly, the RF to IF path is not perfectly linear. This will lead to intermodulation distortion. Odd-order distortion (typically third and fifth order are most significant) will cause spurs within the IF bandwidth or cross-modulation when strong signals are present. Also, the LO switches are not perfectly linear, especially while in the transition region. This can add more distortion to the IF output and will increase loss due to the resistance of the switches.





## Mixer Performance Specifications

- Image rejection ✓
- Conversion gain: voltage or power ✓
- Port-to-port isolation: dBc
- Large signal performance:
  - gain compression:  $P_{1dB}$
  - intermodulation distortion spec: third-order intercept (TOI)
- Small signal performance: noise figure
- Operating range: Spurious-free dynamic range

17

We have already discussed image rejection, conversion gain and isolation. Other performance specifications relate to the mixer's ability to work with very weak and very strong signals.

We would like to maximize mixer performance by:

1. maximize linearity in the signal path
2. idealize switching: high slew rates
3. minimize noise contributions



## Isolation between ports

- The mixer is not perfectly unilateral - leakage between:
  - LO to IF = LO power at IF port/LO power at LO
  - LO to RF = LO power at RF port/LO power at LO
  - RF to IF = RF power at IF port/RF power at RF
- Determine the magnitude of these leakage components at the IF and RF ports using harmonic balance for simulation or spectrum analyzer measurement.

18

Isolation can be quite important for certain mixer applications. For example, LO to RF leakage can be quite serious in direct conversion receiver architectures because it will remix with the RF and produce a DC offset. Large LO to IF leakage can degrade the performance of a mixer postamp if it is located prior to IF filtering.

Doing mixer simulations in harmonic balance results in many frequency components. These can be displayed using the mix function with the proper indices.

**EXERCISE 2:** Modify the data display swmix2.dds to measure the LO to IF, LO to RF, and RF to IF isolation. Express these isolations as power ratios.

(solution in ADS display file ex2.dds)



## Large-signal mixer performance

- Signal statistics
  - 4 sources
  - $P_{avs} = 0 \text{ dBm}$
  - in phase @  $t=0$
  - $\Delta f = 10 \text{ MHz}$

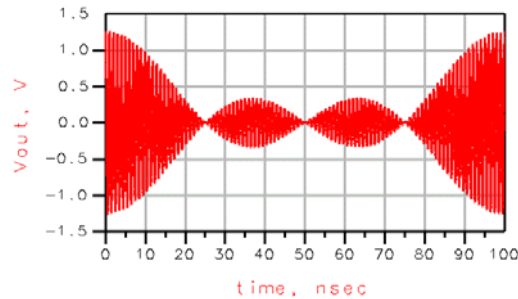

- Peak signal voltage, not average power dictates when distortion becomes excessive.

19

In receiver applications, a mixer is often exposed to several signals within its preselected input bandwidth. It is important to understand that it is the peak signal voltage, not average signal power, that dictates when distortion becomes excessive in an amplifier or mixer. In the example above, 4 carriers, each with 0 dBm average power, are applied to the input. Each signal is separated by 10 MHz and all 4 are in phase at  $t = 0$ . As can be seen above, these signals will appear in phase periodically, with 4 times the peak signal voltage of a single carrier. While we are fond of expressing the large-signal performance in terms of an input power in dBm, let's remember that the time domain instantaneous signal peaks are what stress the system. Real signals are likely to be much more complex than this, so the probability of having a large peak like this is less likely in a real application. But, even infrequent overdrive and distortion generation can degrade bit error rates.

[See ADS example file sigs.dsn]



## Gain Compression

- Conversion gain degrades at large input signal levels due to nonlinearity in the signal path.
- Assume a simple nonlinear transfer function:

$$V_{RF}(t) = v_{in} - a_3 v_{in}^3$$

$$V_{RF}(t) = V_R \left( \underbrace{1 - \frac{3a_3 V_R^2}{4}}_{\text{Gain compression}} \right) \sin(\omega_{RF} t) + \frac{1}{4} a_3 V_R^3 \underbrace{\sin(3\omega_{RF} t)}_{\text{Third-order distortion}}$$

Gain compression    Third-order distortion

- This distortion then gets mixed to the IF frequency

20

*Gain compression* is a useful index of distortion generation. It is specified in terms of an input power level (or peak voltage) at which the small signal conversion gain drops off by 1 dB.

The example above assumes that a simple cubic function represents the nonlinearity of the signal path. When we substitute  $v_{in}(t) = V_R \sin(\omega_{RF} t)$  and use trig identities, we see a term that will produce gain compression:

$$1 - 3a_3 V_R^2/4.$$

If we knew the coefficient  $a_3$ , we could predict the 1 dB compression input voltage. Typically, we obtain this by measurement of gain vs. input voltage. The reduced amplitude output voltage then gets mixed down to the IF frequency.

We also see a cubic term that represents the third-order *harmonic distortion* (HD) that also is caused by the nonlinearity of the signal path. Harmonic distortion is easily removed by filtering; it is the *intermodulation distortion* that results from multiple signals that is more troublesome to deal with.

Note that in this simple example, the fundamental is proportional to  $V_R$  whereas the third-order HD is proportional to  $V_R^3$ . Thus, if  $P_{out}$  vs.  $P_{in}$  were plotted on a dB scale, the HD power will increase at 3 times the rate that the fundamental power increases with input power. This is often referred to as being “*well behaved*”, although given the choice, we could easily live without this kind of behavior!

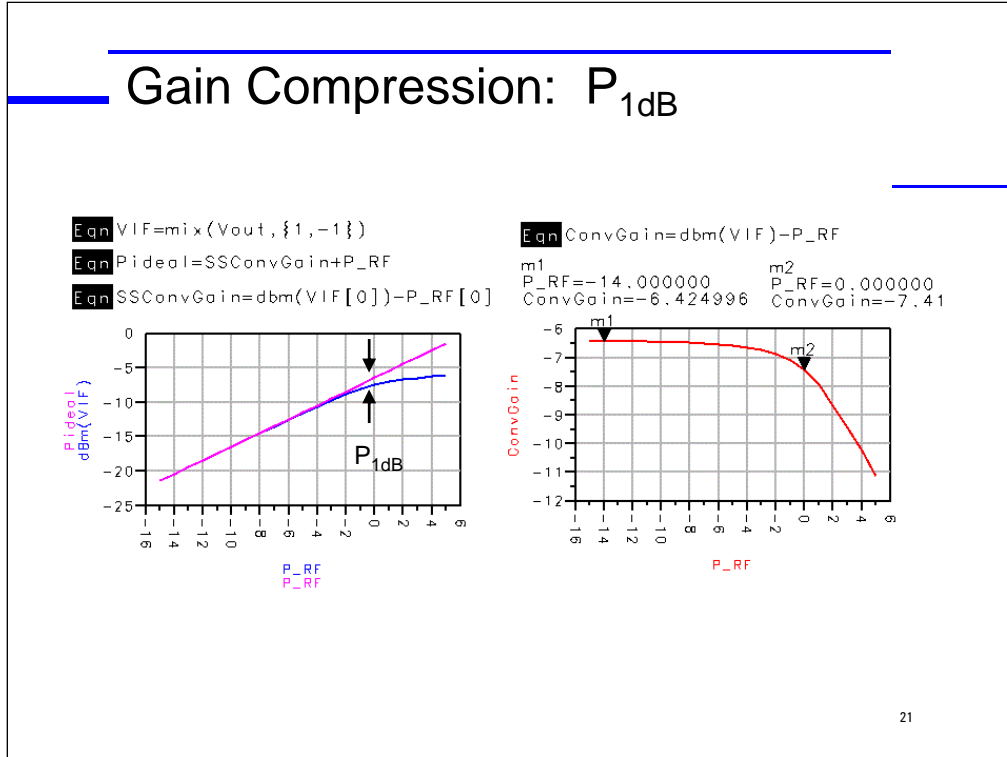

The RF mixer behavioral model in ADS has been used to illustrate the gain compression phenomenon. The input RF power ( $P_{RF}$ ) was swept from -15 dBm to +5 dBm. On the left, we see the simulated IF output power vs. the ideal output power. Ideal output power is calculated from the small signal conversion gain, simulated at the lowest  $P_{RF}$  input power level,  $P_{RF}[0]$ . Here, the index [0] refers to the first entry in the data set for  $P_{RF}$ , -15 dBm. The  $dBm(VIF[0])$  function is used to convert the corresponding first entry in the IF voltage data set IF to power.

VIF is the output voltage at the IF output frequency and must be selected from many frequencies in the output data set. This frequency is selected by using the *mix* function. In this example, LOfreq = 1 GHz and RFfreq = 0.85 GHz. If we are interested in the downconverted IF frequency, 150 MHz, we can select it from:

$$V_{IF} = \text{mix}(V_{out}, \{1, -1\}).$$

The indices in the curly brackets are ordered according to the HB fundamental analysis frequencies. Thus, {1,-1} selects LOfreq – RFfreq.

Other equations are added to the display panel which calculate the conversion gain

$$\text{ConvGain} = \text{dBm}(VIF) - P_{RF}.$$

Here we can identify the 1 dB gain compression power to be about 0 dBm.

**[Refer to ADS example RFmixer\_GC]**



## Use Harmonic Balance simulation

### HARMONIC BALANCE

```

HarmonicBalance
HB1
MaxOrder=8
Freq[1]=LOfreq
Freq[2]=RFfreq
Order[1]=7
Order[2]=3
UseKrylov=yes
SweepVar="P_RF"
Start=-15
Step=10
Step=1
Other=

```

- Highest order of IM products
- Fundamental Frequencies:  
put highest power source first
- Number of harmonics of sources [1] & [2]
- Sweep P\_RF in 1 dB steps from -15 dBm
- Can be used to pass variables to data display

22

Harmonic balance is the method of choice for simulation of mixers. By specifying the number of harmonics to be considered for the LO and RF input frequencies and the maximum order (highest order of sums and differences) to be retained, you get the frequency domain result of the mixer at all relevant frequencies. To get this information using SPICE or other time domain simulators can often require a very long simulation time since at least two complete periods of the lowest frequency component must be generated in order to get accurate FFT results. This becomes a serious problem with two-tone input simulations. Concurrently, the time step must be compatible with the highest frequency component to be considered.

Maximum order corresponds to the highest order mixing product ( $n + m$ ) to be considered ( $nf[1] \pm mf[2]$ ). The simulation will run faster with lower order and fewer harmonics of the sources, but may be less accurate. You should test this by checking if the result changes significantly as you increase order or number of harmonics.

The frequency with the highest power level (the LO) is always the first frequency to be designated in the harmonic balance controller. Other inputs follow sequencing from highest to lowest power.



---

## Intermodulation distortion

---

- IMD consists of the higher order signal products that are generated when two RF signals are present at the mixer input. The IMD will be down and up converted by the LO as will the desired RF signal.
- IMD generation is a good indicator of large signal performance of a mixer.
- Absolute accuracy is highly dependent on the accuracy of the device model, but the relative accuracy is valuable for optimizing the circuit parameters for best IMD performance.

23

The gain compression power characterization provides a good indication of the signal amplitude that the mixer will tolerate before really bad distortion is generated. You should stay well below the  $P_{1dB}$  input level.

Another measure of large-signal capability is the intermodulation distortion. Intermodulation distortion occurs when two or more signals are present at the RF input to the mixer. The LO input is provided as before. These two signals can interact with the nonlinearities in the mixer signal path (RF to IF) to generate unwanted IMD products (distortion) which then get mixed down to IF.



## Intermodulation Distortion

- Let's consider the 3rd order nonlinearity:  $a_3 v_{in}^3$ 
  - two inputs:  $v_{in} = V_1 \sin(\omega_1 t) + V_2 \sin(\omega_2 t)$

$$V_{out3} = a_3 [V_1^3 \sin^3(\omega_1 t) + V_2^3 \sin^3(\omega_2 t) + 3V_1^2 V_2 \sin^2(\omega_1 t) \sin(\omega_2 t) + 3V_1 V_2^2 \sin(\omega_1 t) \sin^2(\omega_2 t)]$$

$$\frac{3V_1^2 V_2 a_3}{2} \left\{ \sin(\omega_2 t) - \frac{1}{5} [\sin(2\omega_1 - \omega_2)t - \sin(2\omega_1 + \omega_2)t] \right\}$$

Cross-modulation
Third-order IMD

24

Let's consider again the simple cubic nonlinearity  $a_3 v_{in}^3$ . When two inputs at  $\omega_1$  and  $\omega_2$  are applied simultaneously to the RF input of the mixer, the cubing produces many terms, some at the harmonics and some at the IMD frequency pairs. The trig identities show us the origin of these nonidealities. [4]

We will be mainly concerned with the third-order IMD. This is especially troublesome since it can occur at frequencies within the IF bandwidth. For example, suppose we have 2 input frequencies at 899.990 and 900.010 MHz. Third order products at  $2f_1 - f_2$  and  $2f_2 - f_1$  will be generated at 899.980 and 900.020 MHz. Once multiplied with the LO frequency, these IMD products may fall within the filter bandwidth of the IF filter and thus cause interference to a desired signal. IMD power, just as HD power, will have a slope of 3 on a dB plot.

In addition, the cross-modulation effect can also be seen. The amplitude of one signal (say  $\omega_1$ ) influences the amplitude of the desired signal at  $\omega_2$  through the coefficient  $3V_1^2 V_2 a_3 / 2$ . A slowly varying modulation envelope on  $V_1$  will cause the envelope of the desired signal output at  $\omega_2$  to vary as well since this fundamental term created by the cubic nonlinearity will add to the linear fundamental term. This cross-modulation can have annoying or error generating effects at the IF output.

Other higher odd-order IMD products, such as 5th and 7th, are also of interest, but may be less reliably predicted unless the device model is precise enough to give accurate nonlinearity in the transfer characteristics up to the  $2n-1^{\text{th}}$  order.





## IMD simulation

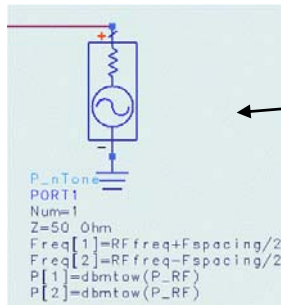

- Use a two-tone generator at the mixer input.
- The two input frequencies are separated by  $F_{spacing}$  and each have an input power of  $P_{RF}$  dBm.

- Large MaxOrder and LO Order are needed for accurate HB TOI predictions with highly nonlinear elements
- Oversampling (Param menu) should also be increased cautiously

```

HarmonicBalance
HB1
MaxOrder=10
Freq[1]=LOfreq
Freq[2]=RFfreq+Fspacing/2
Freq[3]=RFfreq-Fspacing/2
Order[1]=11
Order[2]=3
Order[3]=3
Oversample[1]=2
Oversample[2]=2
Oversample[3]=2
UseKrylov=yes

```

25

The IMD simulation is performed with a two-tone generator at the RF input. The frequency spacing should be small enough so that both fall within the IF bandwidth. You should keep in mind that both of the generator tones are in phase, therefore the peak voltage will add up periodically to twice the peak of each source independently. Because of this, you will expect to see some reduction in the  $P_{1dB}$  on the order of 6 dB.

Often accurate IMD simulations will require a large *maximum order* and *LO harmonic order* when using harmonic balance. In this case, a larger number of spectral products will be summed to estimate the time domain waveform and therefore provide greater accuracy. This will increase the size of the data file and time required for the simulation. Increase the orders in steps of 2 and watch for changes in the IMD output power. When no further significant change is observed, then the order is large enough. Simulation of very low power levels is subject to convergence errors and numerical noise[6].

Sometimes, increasing the *oversampling ratio* for the FFT calculation (use the *Param* menu of the HB controller panel) can reduce errors. This oversampling controls the number of time points taken when converting back from time to frequency domain in the harmonic balance simulation algorithm. A larger number of time samples increases the accuracy of the transform calculation but increases memory requirements and simulation time. Both order and oversampling should be increased until you are convinced that further increases are not worthwhile.



## IF output spectrum

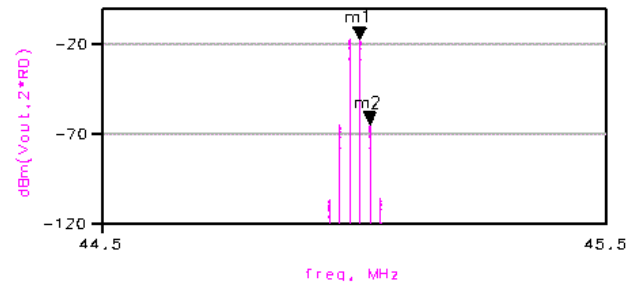

Third-order intermodulation products at  $2f_1 - f_2 - f_{LO}$  and  $2f_2 - f_1 - f_{LO}$  will be present in the IF output.

26

Note that the third-order (m2) and fifth-order products are quite close in frequency to the desired signal (m1). This means that they are often impossible to remove by filtering.

The two IMD sidebands should be approximately of equal power if the simulation is correct. If not, increase the order of the LO in the HB controller and see if this makes the sidebands more symmetric.

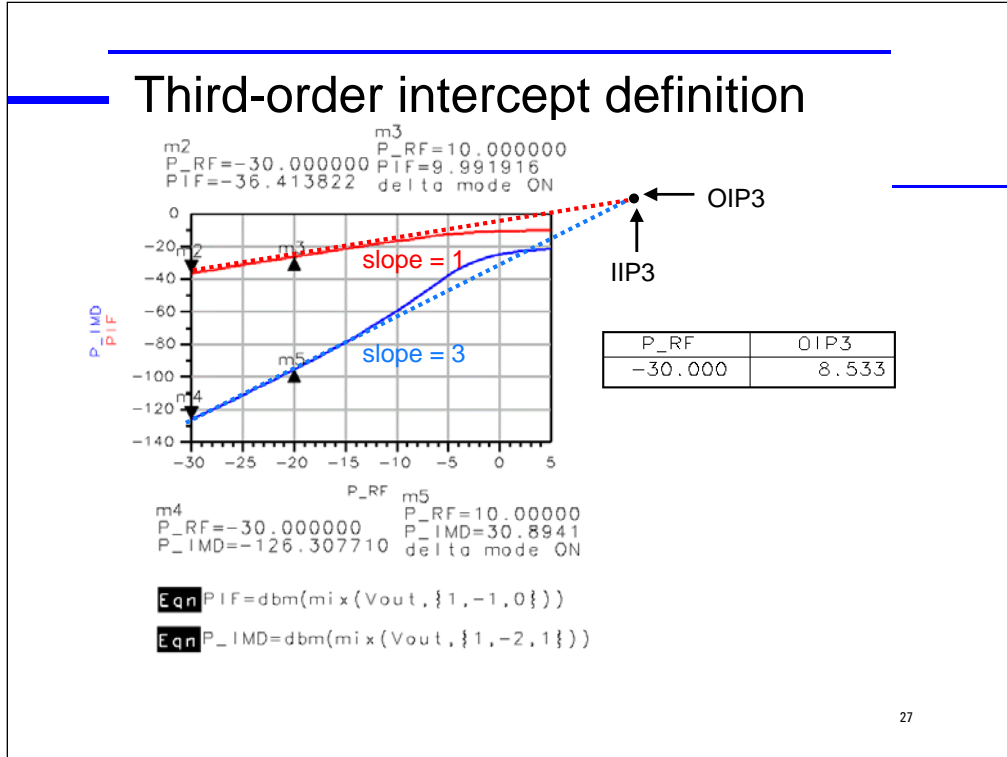

A widely-used figure of merit for IMD is the *third-order intercept* (TOI) point. This is a fictitious signal level at which the fundamental and third-order product terms would intersect. In reality, the intercept power is 10 to 15 dBm higher than the  $P_{1dB}$  gain compression power, so the circuit does not amplify or operate correctly at the IIP3 input level. The higher the TOI, the better the large signal capability of the mixer.

It is common practice to extrapolate or calculate the intercept point from data taken at least 10 dBm below  $P_{1dB}$ . One should check the slopes to verify that the data obeys the expected slope = 1 or slope = 3 behavior. In this example, we can see that this is true only at lower signal power levels.

$$OIP3 = (PIF - PIMD)/2 + PIF.$$

Also, the input and output intercepts are simply related by the gain:

$$OIP3 = IIP3 + \text{conversion gain.}$$

In the data display above, equations are used to select out the IF fundamental tone and the IMD tone, in this case, the lower sideband. The mix function now has 3 indices since there are 3 frequencies present: LO, RF1 and RF2.

**[See ADS example file: RFmixer\_TOI]**



## Measuring IMD Performance

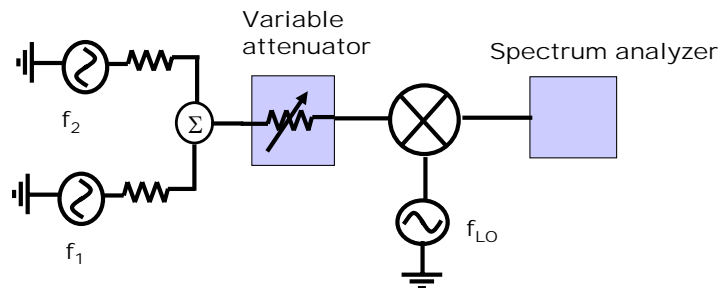

- $P_{IN}$  must be more than 10 dB below  $P_{1dB}$
- Plot data to confirm slope = 3 on IMD
- Use narrow RBW on SA to reduce noise floor

28

Set the amplitude of generators at  $f_1$  and  $f_2$  to be equal.

Start at a very low input power using the variable attenuator, then increase power in steps until you begin to see the IMD output on the spectrum analyzer. The resolution bandwidth should be narrow so that the noise floor is reduced. This will allow visibility of the IMD signal at lower power levels.

Plot the IMD power vs. input power and verify that the slope is close to 3. Then, you can calculate the IP3 as described previously.



## Noise figure & SFDR

- We have been concentrating on the large signal limitations of the mixer. Noise determines the other end of the mixer dynamic range.

- Spurious-free dynamic range:  $NF = 10 \log_{10} \left[ \frac{(S/N)_{in}}{(S/N)_{out}} \right]$

$$SFDR = \frac{2}{3} [IIP3 - (10 \log kT\Delta f + NF)]$$

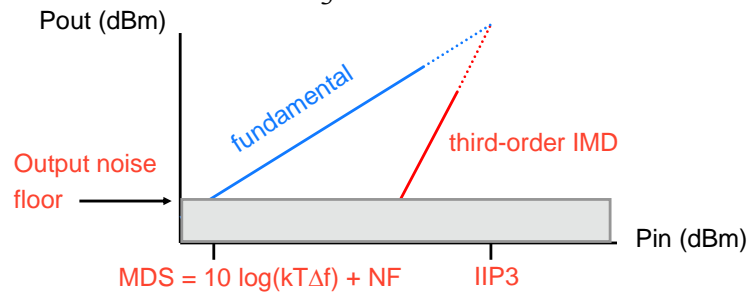

29

*Noise figure* is defined as the ratio between the input and output S/N ratio.

$$NF \text{ (dB)} = 10 \log \left[ \frac{(S/N)_{in}}{(S/N)_{out}} \right]$$

Any real mixer or amplifier will degrade S/N because noise is added to the signal. The *minimum detectable signal* (MDS) power is determined by noise and corresponds to a signal whose strength just equals the noise. The thermal noise power in bandwidth  $\Delta f$  is  $10 \log(kT\Delta f)$  where  $k$  is Boltzmann's constant and  $T$  is absolute temperature. Thus,

$$MDS \text{ (dBm)} = 10 \log(kT\Delta f) + NF$$

since the system generated noise adds to the thermal noise ambient.

The maximum signal power is limited by distortion, which we describe by IIP3. The *spurious-free dynamic range* (SFDR) is a commonly used figure of merit to describe the dynamic range of an RF system. If the signal power is increased beyond the point where the IMD rises above the noise floor, then the signal-to-distortion ratio dominates and degrades by 3 dB for every 1 dB increase in signal power. If we are concerned with the third-order distortion, the SFDR is calculated from the geometric 2/3 relationship between the input intercept and the IMD.

It is important to note that the SFDR depends directly on the bandwidth  $\Delta f$ . It has no meaning without specifying bandwidth.



---

## Determining Noise Figure

---

- Use harmonic balance simulator for mixer NF.
  - takes into account any nonlinearities and harmonics that could mix noise down into the IF band.
- If  $P_{RF} \ll P_{LO}$ , either a 1-tone generator or a passive termination can be used at the input with equal accuracy.
- Noise Figure is calculated.
  - Ideal filter (centered on RF) is added in simulation.
  - Noise contributors within mixer are listed by value
  - For passive switching mixers,  $NF \cong -\text{ConvGain}$

30

The harmonic balance simulator will take into account wideband noise that is generated in the mixer. Some of this noise gets mixed down to the IF frequency from the harmonics of the LO. If the RF signal is of small amplitude, the harmonics that it might generate can be neglected, and either a 1-tone generator or a passive termination can be used. The predictions will be the same. Note that it is essential that the input generator frequency and the HB input analysis frequency be the same.



## SSB or DSB Noise Figure?

- There are two definitions used for noise figure with mixers - often a source of confusion.
- SSB NF assumes signal input from only one sideband, but noise inputs from both sidebands.
- Relevant for heterodyne architectures

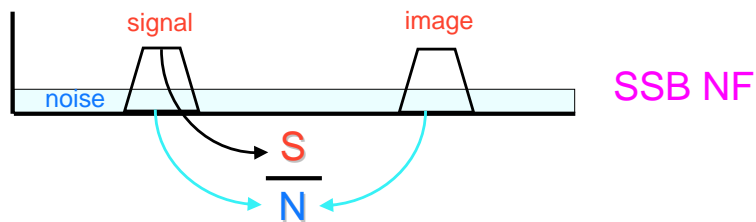

31

Measuring SSB noise figure is relevant for superhet receiver architectures in which the image frequency is removed by filtering or cancellation. Noise figure is generally measured with a wideband noise source that is switched on and off. The NF is then calculated from the “Y factor” [4] and gain does not need to be known. With a SSB measurement, the mixer internal noise shows up at the IF output from both signal and image inputs, but the excess noise is only introduced in the signal frequency band.



## SSB or DSB Noise Figure?

- DSB NF includes both signal and noise inputs from both sidebands. Appropriate for direct conversion architectures.

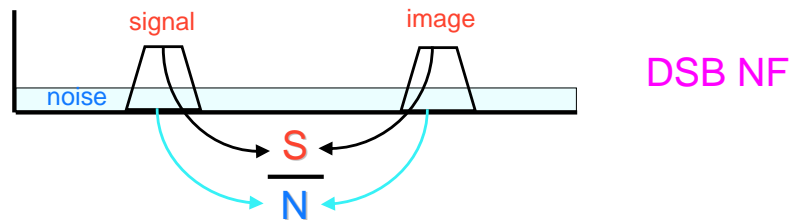

32

A DSB NF is easier to measure; wideband excess noise is introduced at both the signal and image frequencies. It will be 3 dB less than the SSB noise figure in most cases. This is perhaps more relevant for direct conversion receivers where the image cannot be filtered out from the signal.

Either type of measurement is valid so long as you clearly specify what type of measurement is being made.





---

## Mixer circuit examples

---

- OK, now let's look at some examples
  - diode DB quad:
    - familiar and widely used
    - wide bandwidth, limited by baluns
  - FET DB quad:
    - not as well known, but good performance
  - Gilbert multiplier
    - Very widely used active mixer

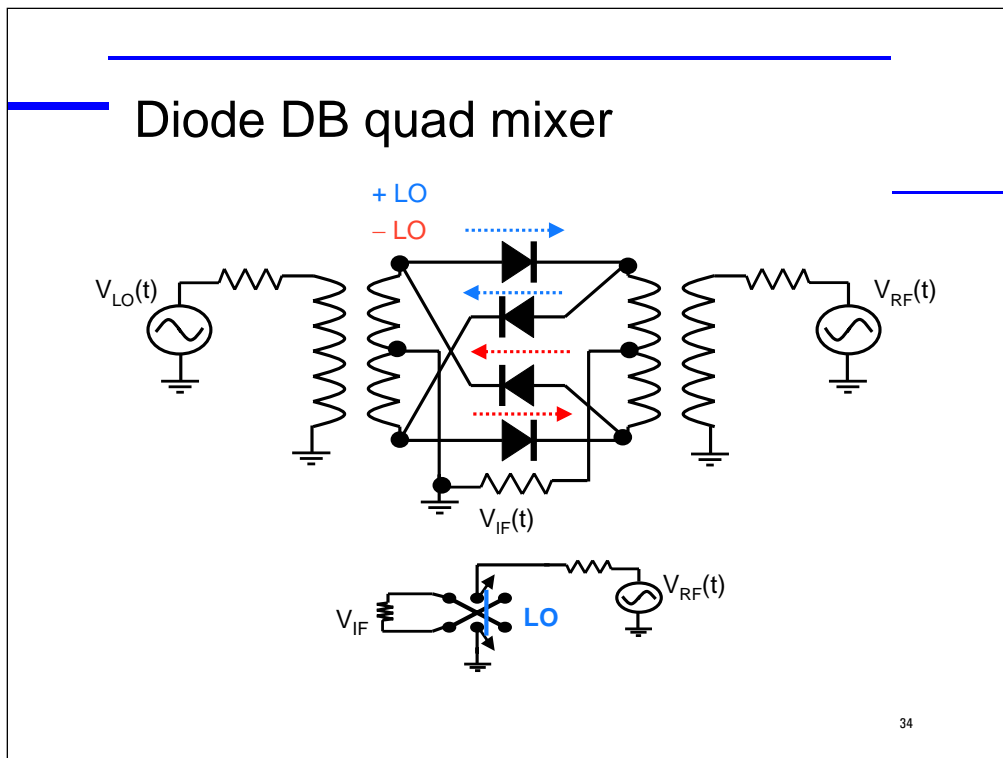

The diode double-balanced quad mixer is a very popular design and available in a wide variety of frequency bandwidths and distortion specs. The MiniCircuits™ catalog [7] is full of these. The diodes act as a polarity reversing switch as seen in the bottom of the figure. When the top of the LO transformer is positive, the blue path is conductive and will ground the top of the RF transformer. When the top is negative, the red path is conducting and the RF polarity reverses. Both LO and RF feedthrough are suppressed by the symmetry and balancing provided by the transformers. The LO signal at the RF and IF ports appears to be a virtual ground for either LO polarity.

Since the LO signal must switch the diodes on and off, a large LO power is required, typically 7 dBm when one diode is placed in each leg, 17 dBm with two diodes per path! With this much LO power, even with good isolation, there may still be significant LO in the IF output.

When the diodes are conducting with LO current  $\gg$  RF current, the mixer should behave linearly. At large RF signal powers, the RF voltage modulates the diode conduction, so lots of distortion will result in this situation. The diodes are also sensitive to RF modulation when they are biased close to their threshold current/voltage. For both reasons, we prefer high LO drive with a fast transition (high slew rate - a square wave LO is better than sine wave) between on and off. The IMD performance is very poor with small LO power.



## Design procedure

- Determine correct RF and LO impedances to match through the diode ring to the 50 ohm IF load. Transformer ratios can be swept using HB or XDB.
- Sweep LO power to maximize conversion gain and gain compression
- Or, buy one from MiniCircuits™!

35

The RF and LO impedances at the diode ring theoretically should be determined and matched at all of the relevant harmonics. [8] For most designs, optimizing the transformer ratios with the IF port connected to 50 ohms should be sufficient, since we cannot select impedances at each frequency independently, and this approach would not be possible for a broadband design such as this.

Exercise 4. Modify the gain compression simulation (diodeDBQ\_GC) to evaluate conversion gain and P1dB as a function of LO power. Use the XDB simulator with a parameter sweep. (solution: ADS file diodeDBQ\_ex4)

Exercise 5. Sweep the RF transformer turns ratio to find the best ratio for conversion gain and P1dB. (solution: ADS file diodeDBQ\_GC\_OPT)

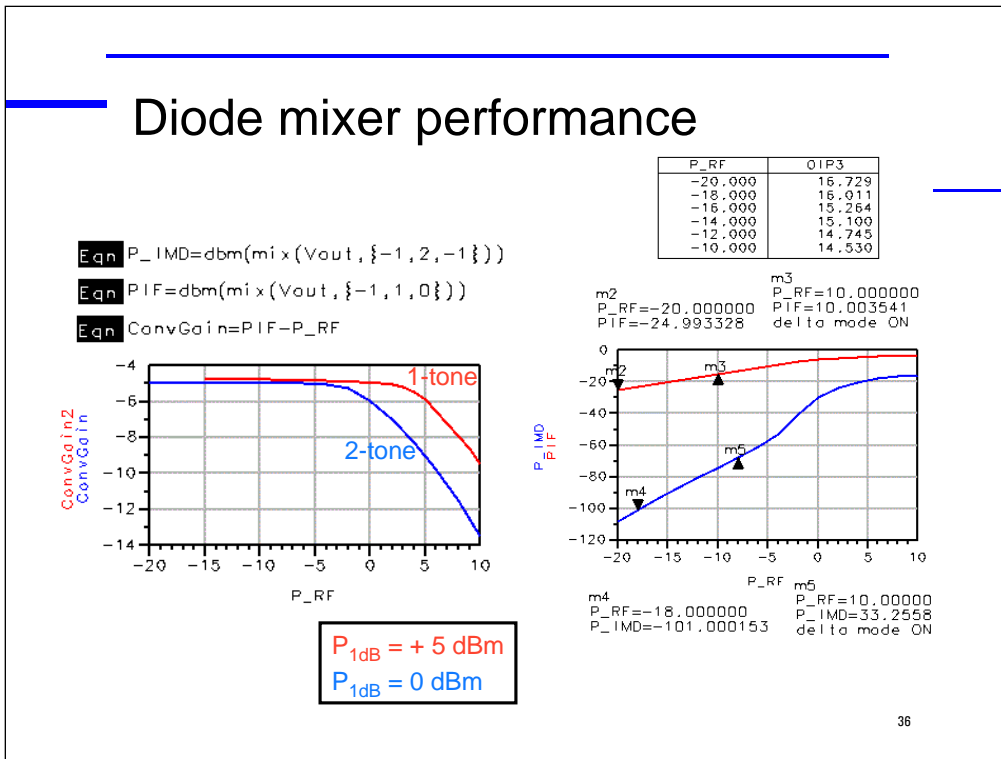

A harmonic balance simulation can be used to estimate the mixer performance. With the DB diode mixer, the currents in the diodes are half wave, so a high number of LO harmonics and maximum order and some oversampling of the FFT operation are necessary to reproduce this waveform and therefore get reasonable accuracy on the third-order product. Gain compression is not as sensitive to the LO order.

Gain compression behavior depends strongly on the signal statistics as discussed earlier. There is about 5 dBm difference in  $P_{1dB}$  between single and two tone simulations.

We see that the third order IMD predictions are not “well behaved”; the slope is 33.2 dB/decade instead of 30. This puts our TOI calculation in doubt, but it is still useful for design optimizations. We can also see that the OIP3 prediction depends upon the RF input power level.

Noise figure of these passive switched mixers is usually close to

$$NF = - ConvGain$$

Thus, for a -5 dB Conversion Gain, a noise figure of about 5 dB is expected.

[See ADS example files diodeDBQ\_TOI and diodeDBQ\_GC]



## Need good match at each port

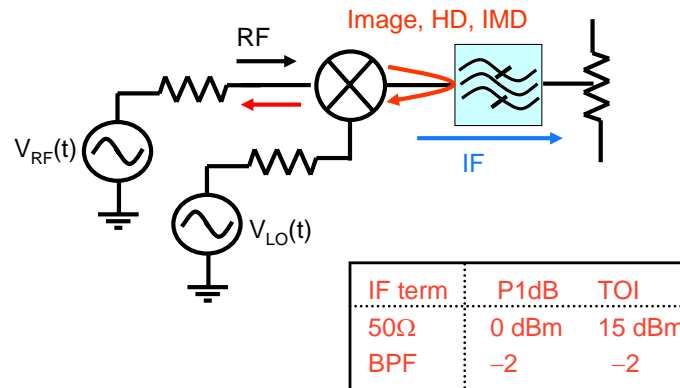

37

Since these passive diode switch mixers are bilateral, that is, the IF and RF ports can be reversed, the performance of the mixer is very sensitive to the termination impedances at all ports. A wideband resistive termination is needed to absorb not only the desired IF output but also any images, harmonics, and IMD signals. If these signals are reflected back into the mixer, they will remix and show up at the RF port and again at the IF port. The phase shifts associated with the multiple replicas of the same signals can seriously deteriorate the IMD performance of the mixer.

A simulation was carried out using a bandpass filter in the IF port as shown above. The  $P_{1dB}$  was degraded by 2 dB and the third-order IMD power was not well behaved. A calculated TOI showed nearly 17 dB degradation.

Thus, it is important to terminate. Terminations can consist of:

1. Attenuator. Obviously not a good idea if NF is important
2. Wideband amplifier with good S11 or S22 return loss
3. Diplexer. A passive network that separates frequencies but provides  $Z_o$  termination for all components.

[See ADS example file: **diodeDBQ\_TOI\_BPF**]



## Mixer termination methods

- Passive diplexer

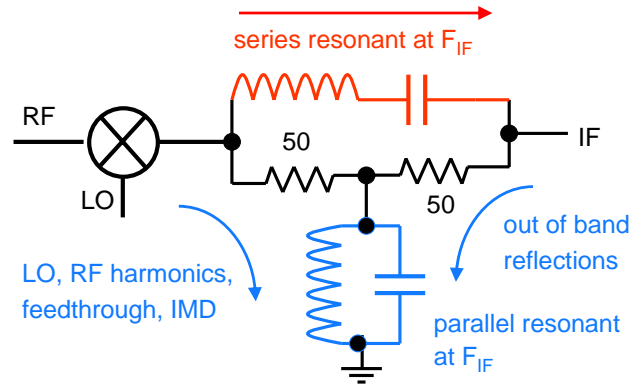

38

This passive diplexer provides a low-loss forward path through the series resonant branch. At  $F_{IF}$ , the parallel resonant branch has a high impedance and does not load the IF. Outside of the IF band (you need to set the Q for the design to control the bandwidths) the series resonant branch presents a high impedance to the signals and the parallel resonant branch a low, but reactive impedance. At these frequencies, above (through C) and below  $F_{IF}$  (through L), the resistors terminate the output. The farther away from  $F_{IF}$  you are, the better the match.



## Mixer termination methods

- Active wideband termination

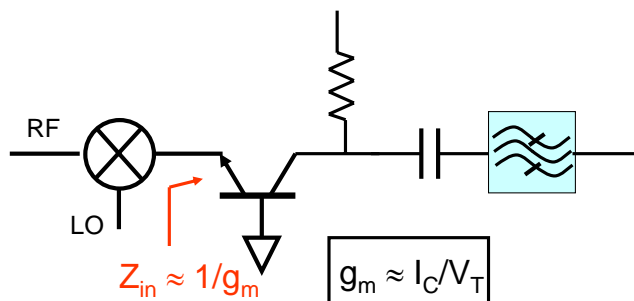

39

This common base stage provides a wideband resistive impedance provided the maximum frequency at the input is well below the  $f_T$  of the transistor. The bias current can be set to provide a 50 ohm input impedance. Alternatively, one can bias the device at higher current levels and add a series resistor at the input. Of course, this degrades noise, but will improve IMD performance. The amplifier must be capable of handling the complete output power spectral density of the mixer without distorting.

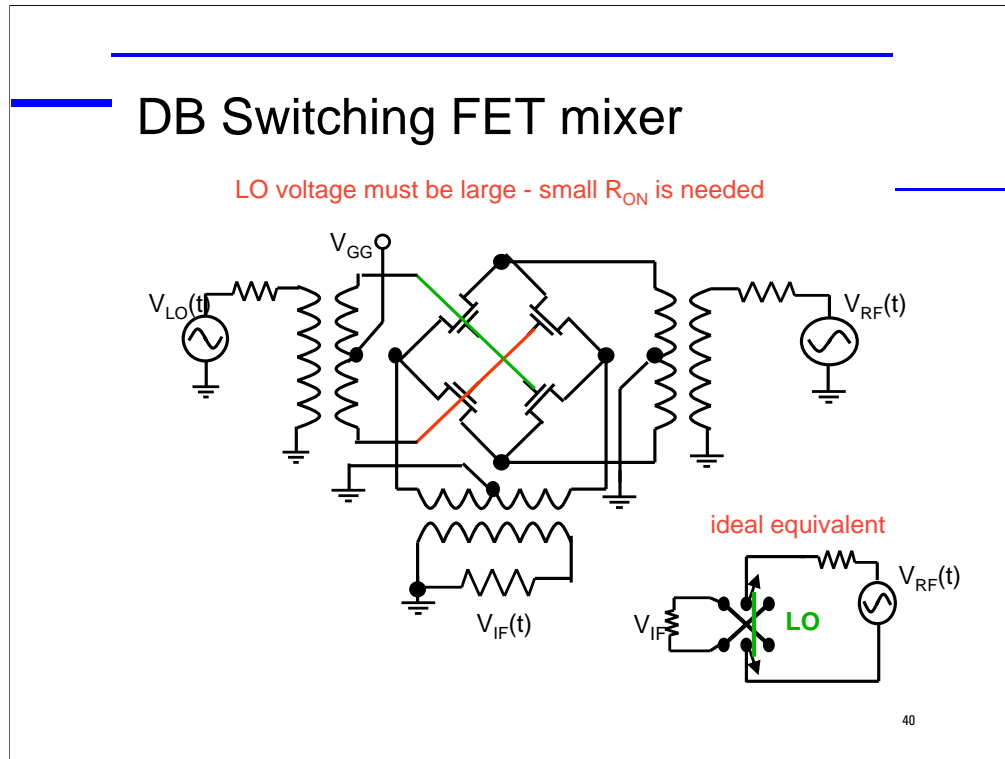

The channel resistance of a large FET when in its triode region (below saturation) can be quite low and is not as current dependent as the diode. Therefore, switching configurations using FETs can be more linear in the RF to IF path than diode switching mixers.

1. The conversion loss will be similar to the diode mixer.
2. Large LO drive voltage is needed (1 to 5 volts)

With the FET ring mixer, devices alternate polarity between the RF input and IF output. If the devices were ideal switches, then the input and output would be directly connected. So, transformers with identical turns ratios should be used. The impedance level at the FET ring should be much higher than the series resistance of the FETs in order to reduce conversion losses. This may also help with linearity. If the impedance is too high, however, LO feedthrough may be higher and frequency response more limited. So, some optimization is needed.







## Passive or Active Mixers?

- Passive nonlinear devices or switches
  - conversion loss, not gain
  - high tolerance to IMD
  - external baluns or transformers needed
- Active mixers
  - can provide conversion gain
  - active baluns - better for IC implementation
  - more difficulty in achieving good IMD performance

42

Passive mixers are widely used because of their relative simplicity, wide bandwidth, and good IMD performance. The transformers or baluns generally limit the bandwidth. They must introduce some loss into the signal path, however, which can be of some concern for noise figure. In this case, an LNA can be introduced ahead of the mixer, usually with some degradation in IMD performance.

Active mixers are preferred for RFIC implementation. They can be configured to provide conversion gain, and can use differential amplifiers for active baluns. Because of the need for additional amplifier stages in the RF and IF paths with fully integrated versions, it is often difficult to obtain really high third-order intercepts and 1 dB compression with active mixers.

The mixer designs shown previously are passive. The devices are acting as switches and are not active - therefore we have conversion loss, not gain. Also, if the balancing involves transformers, then integrating onto an IC is not usually possible. So, other implementations that provide gain and are more amenable to integration are frequently used in IC front end chips.

The design objectives are generally the same however:

1. maximize linearity in signal path
2. idealize switching in LO path
3. minimize the noise contribution due to thermal and shot noise



## Diff pair is basis for active mixer

$$\Delta I_C = I_{C1} - I_{C2} = I_{EE} \tanh(V_{id} / 2V_T)$$

$$V_{id} = V_{in+} - V_{in-}$$

$U = V_{id} / 2V_T$

43

(read Gray and Meyer, Sec. 10.3)

The emitter-coupled pair can be used to provide multiplication if the input range limitations are observed. Here we have a differential transconductance stage with voltage  $V_{id}$  as input and  $\Delta I_C$  as output. If  $V_{id} \ll 2V_T$ , then

$$\Delta I_C \approx I_{EE} (V_{id} / 2V_T) = g_m V_{id}$$

Since the transconductance  $I_{EE} / 2V_T$  can be varied with  $I_{EE}$ , a second input can be added which will produce a 2 quadrant multiplication.

$$\tanh(u) = u - \frac{1}{3}u^3 + \frac{2}{15}u^5 - \dots$$

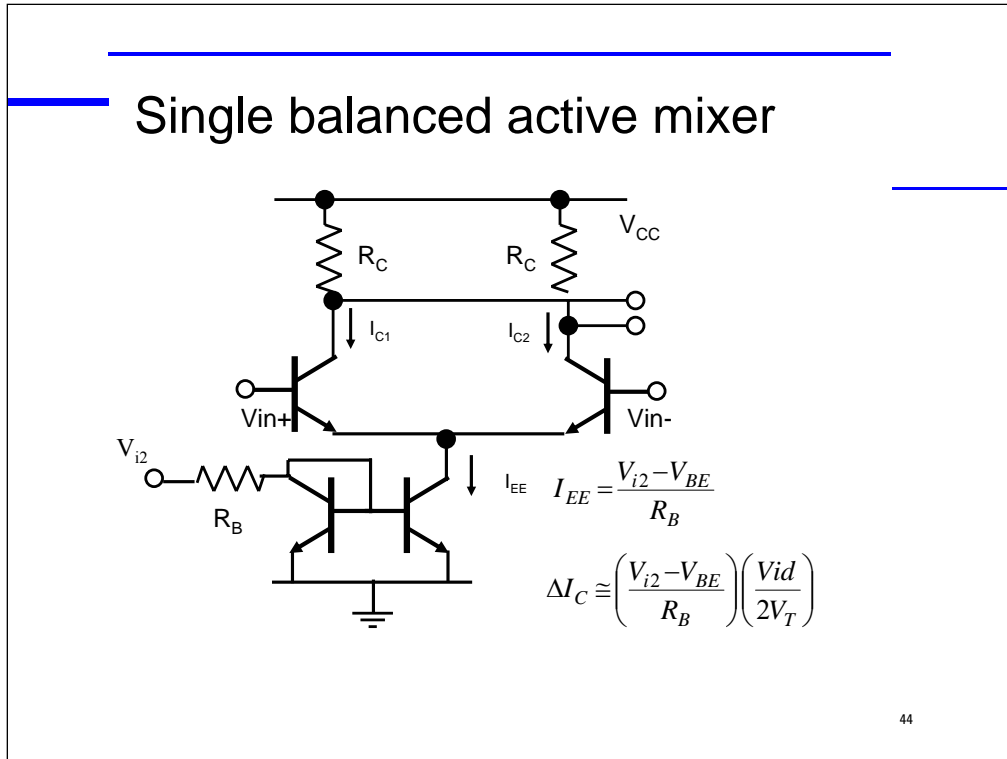

But,  $V_{i2} > V_{BE}$  and  $V_{id}$  must be small,  $\ll V_T$ . Rather limited use.

In the terminology of mixers, this is a single balanced mixer. If we apply  $V_{LO}$  to  $V_{id}$  and keep  $V_{i2}$  constant, our output is full amplitude at the LO frequency. NOT DESIRABLE - will desensitize the IF amplifier. So, we really should go one step further and design a doubly balanced mixer to suppress the LO feedthrough.

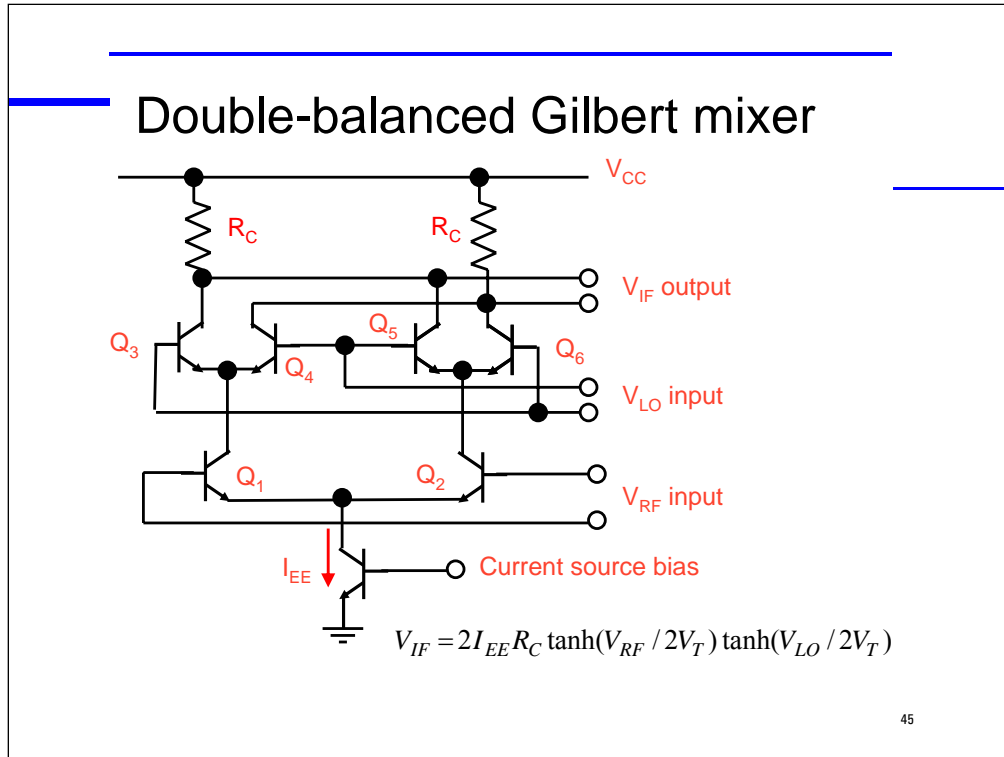

This double-balanced active mixer was first described in the 60's. Barrie Gilbert (now of Analog Devices) was awarded the patent.

We can make several observations on this remarkably useful circuit:

1. Q3 - Q6 provide a fully balanced, phase reversing switch. When  $V_{RF} = 0$ ,  $I_{OUT}$  also is 0 regardless of the status of  $V_{LO}$ . This is because  $I_{C3-5}$  and  $I_{C4-6}$  each will add up to  $I_{EE}/2$  in this condition.
2. When  $V_{LO} \neq 0$ , the same condition applies. Therefore, there is never any LO component in the output differential current. The upper tier of BJTs only provides the phase reversal of the RF signal as controlled by the LO voltage.
3. The mixer can provide conversion gain - depending on the load impedance presented to the collectors and  $I_{EE}$ .
4. The signal handling capability is still limited below  $V_T$ , but we can use emitter degeneration to improve linearity.
5. The distortion is entirely odd-order for perfectly matched transistors.



## Gilbert multiplier

- Easily integrated with other circuits
- Better isolation than the DB diode or FET mixers
- Requires less LO power than the passive mixers
- Less fussy about IF termination impedance than the passive mixers due to the better isolation
- Its main liability is large signal handling capability
  - IIP<sub>3</sub> is much lower than passive mixers

46

### Linearity of RF → IF path:

We have seen that the RF input diff pair converts the input voltage into a differential current. The RF → IF path is supposed to be very linear. We can analyze the transfer function for linearity and distortion:

$$\Delta I = I_{EE} \tanh(V_{LO}/2V_T) \tanh(V_{RF}/2V_T)$$

The LO input is intentionally overdriven so that it is just acting as a polarity switch. So, we only need to investigate the behavior of the RF port

Let's normalize:  $U = V_{RF}/2V_T$ . Then, the gain is the derivative of  $\tanh U$

$$\text{gain} = I_{EE} \text{sech}^2 U$$

To evaluate the linearity, we must remember that it is the instantaneous peak voltage at the input that drives the stage into nonlinearity, not the average voltage. From the graph on the next page, we can see that the  $\tanh$  function is not very linear. The incremental gain predicted by the  $\text{sech}^2 U$  function is down by 10% for inputs with a peak-to-peak voltage as small as  $U = 0.66$  or 34 mV. This is very close to the 1 dB gain compression input power. The 50Ω referred input power that corresponds to this is -18.7 dBm, not a very high  $P_{1dB}$ .



## Gain function for RF input

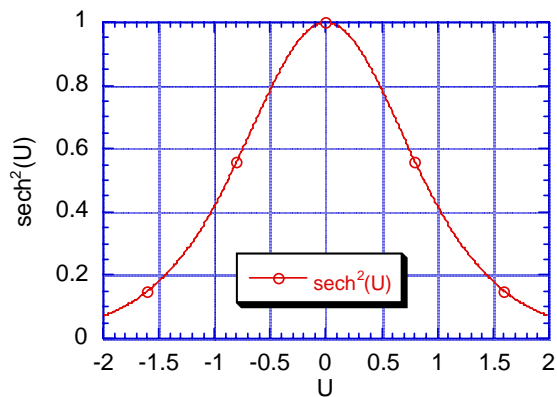

47

Gain drops 10% for inputs as small as  $U = \pm 0.33$ . This corresponds to an amplitude of only 17 mV and is approximately the 1 dB compression input voltage. This is -19 dBm in a 50 ohm system.



## Linearity of RF -> IF path

To predict 3<sup>rd</sup> order harmonic or IM distortion produced by the tanh function, use a Taylor series approximation

$$\tanh(U) \cong U - U^3/3 \quad \text{Accurate to 1\% to } U = 0.55$$

Let  $U = U \sin \omega t$ . Then,

$$\begin{aligned} \tanh(U \sin \omega t) &\cong U \sin \omega t - (U \sin \omega t)^3/3 \\ &= U \sin \omega t - (U^3/12)(3 \sin \omega t - \sin 3\omega t) \\ &= U(1 - U^2/4) \sin \omega t + (U^3/12) \sin 3\omega t \end{aligned}$$

48

Next, choose some small single frequency value for  $U$ . We can calculate the fundamental and third harmonic amplitudes from the series terms and predict the 3<sup>rd</sup> order intercept point,  $P_{3OI}$ , for harmonic distortion.

Let  $U = 0.01$ . This corresponds to an amplitude of  $U \cdot 52$  mV or a power  $P_{IN}$  (in  $50\Omega$ ) of  $V^2/2R = 2.7$  nW or  $-55.7$  dBm. Then, the fundamental term

$$U(1 - U^2/4) = 0.00999 \quad \text{negligible gain compression}$$

predicts  $P_{OUT}$  of  $-55.7$  dBm and the third harmonic is

$$(U^3/12) = 8.33 \times 10^{-8}$$

for a  $P_3$  of  $-157$  dBm.

$$P_{3OI} = P_{IN} + (P_{OUT} - P_3)/2 = -5 \text{ dBm} = \text{IIP3}$$

Note that the calculation can be reversed to predict what input  $U$  is required for a known HD3 level (dBc) as predicted by  $P_{3OI}$ . The HD3 level is specified by dBc,  $P_{OUT} - P_3$  (dB below the fundamental power “carrier”= $c$ ).





## Extend input range with emitter degeneration

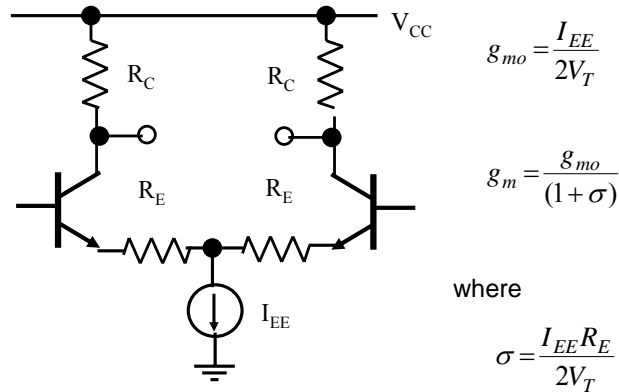

49

**Emitter Degeneration** can be used to extend the input range and linearize the incremental gain of the amplifier.

The emitter-base  $r_e = 2V_T/I_{EE}$  leads to a  $g_{mo} = 1/r_e$ . The factor of 2 comes from having the emitter current source divided between Q1 and Q2. At small signal, each DC emitter current is  $I_{EE}/2$ .

When an external resistor  $R_E$  is added, the gain is reduced because of the local negative feedback. Emitter currents flow in these resistors and subtract from the input voltage. If we define a dimensionless parameter  $\sigma$  to indicate the amount of degeneration,

$$R_E = 2\sigma V_T/I_{EE}.$$

Then,  $g_m = g_{mo}/(1 + \sigma)$

This will lower the conversion gain, but raise the third-order intercept.

The next table shows that the incremental gain is reduced but made more linear.



## Emitter degeneration

$\sigma = I_{EE}R_E/2V_T$	$V_{1dB}$ (mV)	$P_{1dB}$ (dBm)	$P_{3OI}$ (dBm)
0	36	-18.7	-5
0.5	64	-13.8	+0.4
2.0	158	-6.0	+9.4
5.0	361	+1.1	+18.3

$$V_{1dB} \cong 36 \text{ mV} (1 + 1.7\sigma)$$

50

B. Gilbert. Design Considerations for BJT Active Mixers. 1995.

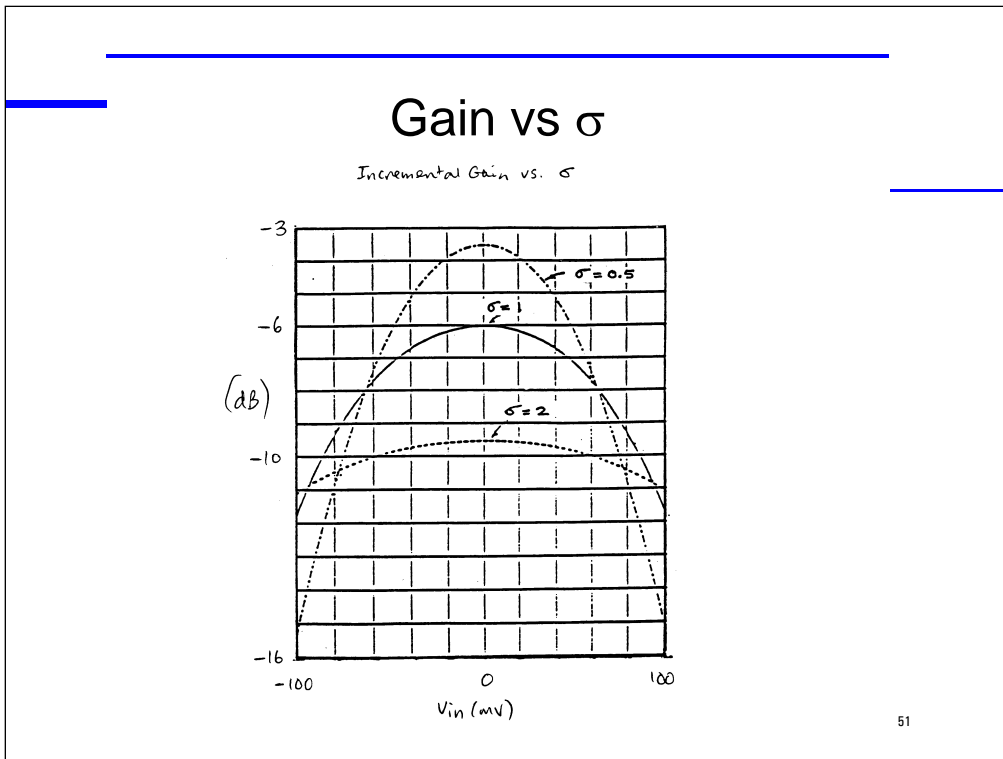

B. Gilbert. Design Considerations for BJT Active Mixers. 1995.



## Mixer dynamic range

- We have explored one dimension: distortion
- But, emitter degeneration will increase noise
  - SFDR = 2/3 (IIP3 – MDS)

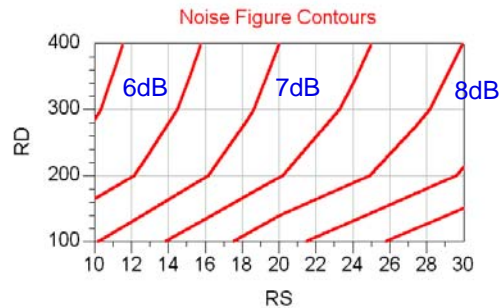

52

### Noise Analysis of Diff Amp. If we

1. assume that the conversion gain of the mixer is high enough to make the second stage contribution of any collector load devices small, and
2. if we neglect the effect of the base resistance of the BJTs, we can make a simple estimate of the noise behavior of this mixer.

Upon neglecting these sources, we are left only with the shot noise associated with the base-emitter forward biased pn junction. Shot noise is caused by random flow of carriers across a junction. Each carrier is emitted individually and so the current arriving across the junction consists of tiny pulses randomly distributed in time.

This produces a noise current whose mean square variance is given by

$$\overline{i_N^2} = 2qI_{DC}B.$$

Here,  $q$  is the electron charge, and  $B$  is the noise equivalent bandwidth. Typically, we normalize to a 1 Hz bandwidth centered on some “spot” frequency. Then this is a noise spectral density.



# BJT Noise Analysis

T model for BJT

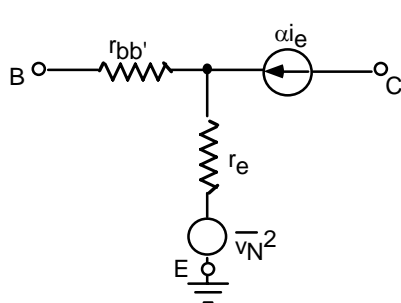

$$r_e = V_T / I_C$$

$$i_N^2 = 2qI_C B$$

$$\bar{v}_N = V_T (2q/I_C)^{1/2}$$

53

In the bipolar transistor, the noise current spectral density is  $i_N = (2qI_C)^{1/2}$  with collector current  $I_C$ . This noise current flows through the noiseless resistor  $r_e$  to produce a noise voltage at the BJT input at  $V_{BE}$ .

$$\bar{v}_N = \bar{i}_N r_e = V_T (2q/I_C)^{1/2}$$



## Noise of differential pair

Random noise sources add in an RMS sum, so the two in series produce  $\sqrt{2}$  times more noise

$\bar{V}_{n,diff} = 2 V_T(2q/I_{EE})^{1/2}$  or

$0.925 \text{ nV}/\sqrt{\text{Hz}}/\sqrt{I_{EE}(\text{mA})}$

54

Applying this to the diff pair, we have two such noise sources in series in the input loop. Random noise sources add in an RMS sum, so the two in series produce  $\sqrt{2}$  times more noise. Also, each transistor has a collector current  $I_C = I_{EE}/2$ . Thus the input noise =  $2 V_T(2q/I_{EE})^{1/2}$  or

$$0.925 \text{ nV}/\sqrt{\text{Hz}}/\sqrt{I_{EE}} \quad (\text{I is in mA})$$

roughly  $1 \text{ nV}/\sqrt{\text{Hz}}/\sqrt{\text{mA}}$ . Here we see that the noise can be reduced when the emitter current is increased.

There is a point of diminishing returns, however, when the base resistor  $r_{bb}$ , dominates the noise. Also, there will be noisy base current flowing through the input source resistor that increases at higher currents. So the above estimate from shot noise only gives the minimum for the noise of the diff pair.

If we take the base current into account, and have a finite source resistance,  $R_S$ , there will be another series noise voltage due to  $I_B (R_S + r_{bb})$ . The total noise gets worse as  $f \rightarrow f_T$  since  $\beta(f) = \beta_{DC} f_T/f$  thus higher  $f_T$  will help to reduce noise (unless it was obtained at the expense of  $r_{bb}$ ).

$$\bar{v}_{n,total}^2 = \left( \frac{0.925 \text{ nV} / \sqrt{\text{Hz}}}{\sqrt{I_{EE}}} \right)^2 + \left[ \frac{(2r_{bb} + R_S)\sqrt{qI_{EE}}}{\beta(f)} \right]^2 + 4kT(r_{bb} + R_S)$$

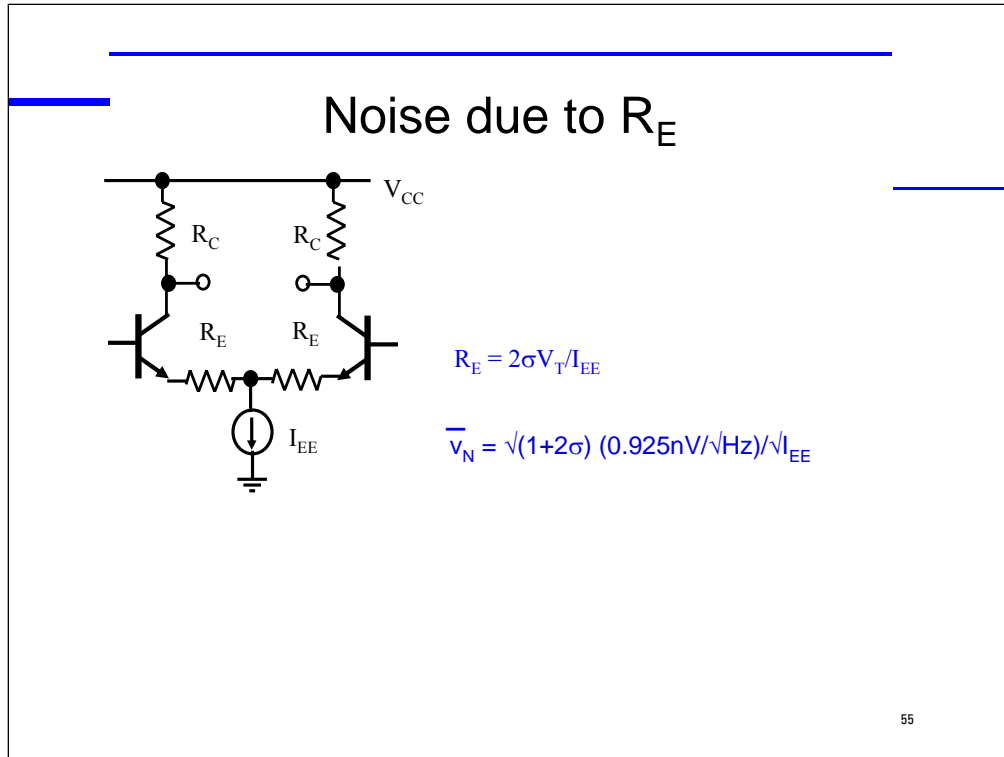

We saw that the emitter degeneration made a big difference in the upper end of the dynamic range. But, it will also increase the noise at the input, raising the noise floor. We can estimate how much the noise will be increased by the emitter resistors. Adding two resistors  $R_E$  in the base-emitter loop will introduce a thermal (Johnson) noise spectral density of  $\sqrt{2} (4kTR_E)^{1/2}$ . This is equal to

$$\bar{v}_{N,RE} = (0.129 \text{ nV}/\sqrt{\text{Hz}}) \sqrt{(2R_E)}.$$

Replacing  $R_E$  with  $\sigma$ , and adding the shot noise, we get the total noise approximately equal to

$$\bar{v}_N = \sqrt{(1+2\sigma)} (0.925\text{nV}/\sqrt{\text{Hz}}) / \sqrt{I_{EE}}.$$

At the upper end of the dynamic range, the data for  $V_{1\text{dB}}$  in the previous table can be estimated to increase by a factor of  $(1+1.7\sigma)$ . So, we can estimate that the dynamic range of the mixer will be increased by emitter degeneration according to:

$$20 \log_{10} [(1+1.7\sigma)/\sqrt{(1+2\sigma)}].$$

For example, if we choose a  $\sigma = 10$  and set  $I_{EE} = 1 \text{ mA}$ , then the input referred noise will be increased from 0.925 to 4.25 nV/ $\sqrt{\text{Hz}}$ , a factor of 4.6. But, the peak input voltage will be increased by a factor of 18. So, there would be nearly a 12 dB improvement in  $P_{1\text{dB}} \text{ DR}$ .

B. Gilbert. Design Considerations for BJT Active Mixers. 1995.



## Differential-to-single ended

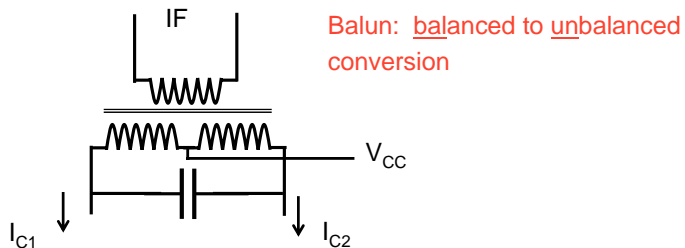

- Transformer
  - Match to load
  - Self-inductance can resonate collector and package C
  - This allows higher IF frequencies to be used

56

Refer to the tutorials on RF transformers for more information on these passive devices. Above 500 MHz, useful ferrite core materials are not available, so transmission line balun transformers are used.

Refer to [mail.ece.ucsb.edu/~long/ECE145B](mailto:mail.ece.ucsb.edu/~long/ECE145B)

Guidelines for design of wideband RF transformers

MiniCircuits App Note: How RF transformers work





## Active Balun: differential to single-ended RF out

- Connect differential amplifier stage to output of tuned mixer.
- Choose either direct output as shown (with off-chip load resistor) or use an emitter follower.
- Size the BJTs according to the output current and voltage required. Their input capacitance can be absorbed in the mixer tank circuit.
- Determine  $R_{E\_D2S}$  so that the D2SE block does not degrade the dynamic range.

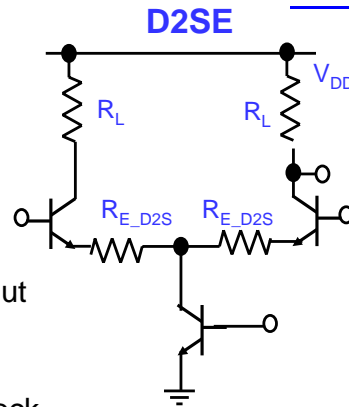

57

The next step will be to convert the RF output from a differential signal to single-ended with an active balun. You should perform this conversion with the active balun rather than just taking one output from the mixer to avoid a 6 dB loss in conversion gain. Since an IF filter is often the next stage to follow the mixer, a single ended output is sufficient.

This differential amplifier stage is used to convert the differential output of the tuned mixer to a single output. The base capacitances of the D2SE stage can be absorbed into the resonator at the mixer collector nodes. The D2SE stage must also be designed so that it does not dominate the IMD generation of the mixer.  $R_{E\_D2SE}$  can be adjusted to set the  $V_{1dB}$  level.

The output driver could use an off-chip load resistor with open collector output connection as suggested by the circuit simulated here. The load resistance will probably be determined either by the filter impedance or by transmission line impedance. The bias current for the D2SE converter stage will be dictated by this impedance level. The device widths must also be chosen so that they can handle the necessary collector current and provide adequate voltage gain. The addition of an emitter follower to the output is another option.



---

## Conclusion



### Learning objectives:

- Understand operating principles of the mixer
- What makes a good mixer?
- Choices: nonlinear/switching mode; single/double balance; active/passive
- Specify performance: Gain, NF,  $P_{1dB}$ , TOI, SFDR, isolation
- Mixer examples - numerous other possibilities



## References



- [1] Gray, P. R. and Meyer, R. G., *Design of Analog Integrated Circuits*, 3rd Ed., Chap. 10, Wiley, 1993.
- [2] Gilbert, B., "Design Considerations for BJT Active Mixers", Analog Devices, 1995.
- [3] Lee, T. H., *The Design of CMOS Radio-Frequency Integrated Circuits*, Chap. 11, Cambridge U. Press, 1998.
- [4] Hayward, W., *Introduction to Radio Frequency Design*, Chap. 6, American Radio Relay League, 1994.
- [5] Razavi, B., RF Microelectronics, Prentice-Hall, 1998.
- [6] Maas, S., "Applying Volterra Series Analysis," *Microwaves and RF*, p. 55-64, May 1999.
- [7] Minicircuits RF/IF Designers Handbook, www.minicircuits.com
- [8] Maas, S., "The Diode Ring Mixer", *RF Design*, p. 54-62, Nov. 1993.
- [9] Maas, S., "A GaAs MESFET Mixer with Very Low Intermodulation," *IEEE Trans. on MTT*, MTT-35, pp. 425-429, Apr. 1987.

59

## References

- [1] Gray, P. R. and Meyer, R. G., *Design of Analog Integrated Circuits*, 3rd Ed., Chap. 10, Wiley, 1993.
- [2] Gilbert, B., "Design Considerations for BJT Active Mixers", Analog Devices, 1995.
- [3] Lee, T. H., *The Design of CMOS Radio-Frequency Integrated Circuits*, Chap. 11, Cambridge U. Press, 1998.
- [4] Hayward, W., *Introduction to Radio Frequency Design*, Chap. 6, American Radio Relay League, 1994.
- [5] Razavi, B., RF Microelectronics, Prentice-Hall, 1998.
- [6] Maas, S., "Applying Volterra Series Analysis," *Microwaves and RF*, p. 55-64, May 1999.
- [7] Minicircuits RF/IF Designers Handbook, www.minicircuits.com
- [8] Maas, S., "The Diode Ring Mixer", *RF Design*, p. 54-62, Nov. 1993.
- [9] Maas, S., "A GaAs MESFET Mixer with Very Low Intermodulation," *IEEE Trans. on MTT*, MTT-35, pp. 425-429, Apr. 1987.