

Outcomes: Core Competencies for ECE145A/218A

1. Transmission Lines and Lumped Components
 1. Use S parameters and the Smith Chart for design of lumped element and distributed L matching networks
 2. Able to model (Agilent ADS, Sonnet) and measure (network analyzer) nonideal lumped components and transmission lines at high frequencies
2. Amplifier performance metrics
 1. Analysis of large signal limitations of amplifiers: gain compression, harmonic and intermodulation distortion.
 2. Use harmonic balance simulation to predict large signal limitations
 3. Familiar with the use of signal to noise ratio, noise figure, noise temperature, and the measurement and simulation of noise figure
3. Small Signal Amplifiers:
 1. Able to use network analyzer to measure gain and phase of amplifiers
 2. Derive gain, reflection, and transmission coefficients.
 3. Use S-parameters with gain and stability circles to design and build stable bandpass amplifiers.
 4. Able to use two-port noise parameters, noise and available gain circles to analyze, design, build and test a low noise amplifier. Use of noise figure measurement equipment.
 5. Able to design stable DC bias circuits for amplifiers
 6. Use spectrum analyzer to measure gain compression, harmonic and intermodulation distortion.
4. Receiver Systems:
 1. Use of mixers for frequency conversion
 2. Understand MDS, images, noise figure, intercept points, dynamic range and their relationship to receiver performance.
 3. Strengths and weaknesses of direct conversion vs. superhetrodyne architectures.

The objectives listed do not give the complete wireless communication experience. 145B/218B will be following up on this foundation and building more knowledge and design experience. This course deals with:

Mixers, VCOs, PLL, Demodulation, Frequency synthesis

146A,B in winter and spring are also strongly recommended as a complementary courses in Comm. Theory.

Note Set #1: Nonideal Components

Goals:

1. See that familiar lumped element components when used at radio frequencies exhibit undesirable parasitics that significantly affect their impedance as a function of frequency.
2. Understand that equivalent circuit models must be used to adequately represent such components.
3. Become acquainted with the concept of Q , quality factor, for components and for the components when used in resonant circuits.

The components that you have used in the past are considered “lumped elements”. As you will see, at high frequencies these are less than ideal, and can have impedances that are different from what you might expect. For this reason, we will later consider “distributed element” implementations that use transmission lines instead of L 's or C 's. But, first consider lumped elements.

Why are the nonidealities of components important?

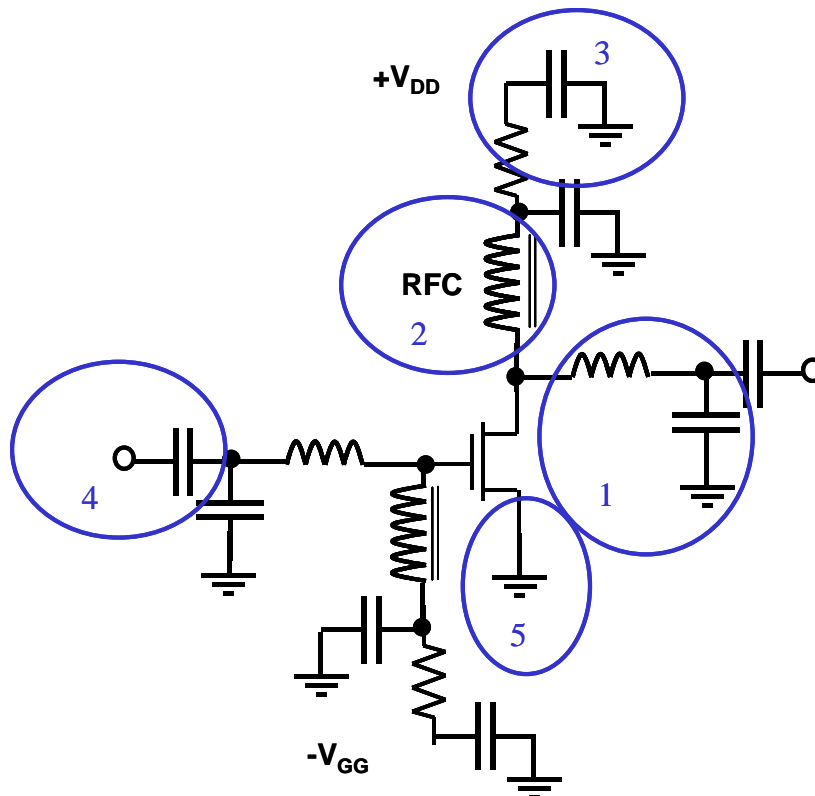

1. Narrow band matching networks. Design frequency is sensitive to component parasitics.
2. Bias networks. RF Choke. Must be broadband, presenting high Z to device over wide frequency range. Parasitic C causes resonances.
3. Bypass Capacitors. Needed to keep signal out of power bus. Must present low Z over wide frequency range. Parasitic L causes resonances.
4. DC Block. Needed to keep DC bias from measurement equipment or other stages. Must provide low Z at design frequency.
5. Ground. Parasitic series inductance can produce resonances, detune matching networks, produce common mode feedback.

Component equivalent networks.

Wire.

In the past you have become accustomed to using wire to interconnect components when prototyping an analog or digital circuit. Most likely, you have considered the wire to be a zero ohm ideal connection that can be ignored in the design of your circuit. This is definitely not a good assumption when building circuits that operate in the radio frequency or microwave spectrum (10 MHz to 26 GHz).

Because a current flows through the wire, a magnetic field is induced around the wire. With a high frequency AC current, the magnetic field causes an induced voltage in the wire that opposes the change in current flow (remember that you cannot change the current through an inductor instantaneously). This effect presents itself as a self-inductance, L, and can be modeled as shown below.



An estimate of the self-inductance can be obtained from this empirical formula¹:

$$L = 0.002l \left[\ln \left(\frac{4l}{d} - 0.75 \right) \right] \mu H$$

where l = length of wire in cm and d = diameter of the wire in cm. According to this formula, 1 inch (2.5cm of wire) with a diameter of 1 mm will have 16 nH of inductance. This is $100j\Omega$ at 1 GHz, a very significant reactance.

Remember! 1 inch = 16 nH = $100j\Omega$ at 1 GHz

The resistance of the wire, also shown in the equivalent circuit above, can sometimes be important for the circuit as well. This is especially true if the wire is being used

¹ C. Bowick, RF Circuit Design, Ch.1, Butterworth-Heinemann, 1982.

intentionally to fabricate an inductor for use in a series or parallel resonant circuit. The resistance increases loss, decreases unloaded Q (to be defined later) and will increase the bandwidth of the resonance.

It is easy to estimate the reactance of an inductor. Note that:

$$1 \text{ nH} = 6 \text{ j}\Omega \text{ at } 1 \text{ GHz}$$

Likewise, $1 \text{ }\mu\text{H} = 6\text{j}\Omega$ at 1 MHz, $60\text{j}\Omega$ at 10 MHz, and so on.

Resistors.

You have also used leaded resistors extensively in the prototyping of transistor circuits. If you think about the leaded resistor, however, in the context of the above discussion, you can see that the high frequency equivalent circuit of the resistor must also include some inductance. In addition, because the ends of the resistor are generally at different potentials, you might expect to see some parallel capacitance too. So, an equivalent circuit model of the resistor would look like this:



Or this:



The frequency dependence of this circuit shows some surprising behavior at high frequencies as shown in Fig. 1.4² If you must use leaded resistors, keep the leads very short. Of course, for DC purposes, the leaded resistor is fine. A leaded resistor could have a series inductance of about 10 nH and a parallel capacitance of about 0.5 pF.

Because of the inductance problem, you often will use chip resistors instead of leaded resistors if they are to be used at high frequencies. You will grow to appreciate these for their electrical performance and possibly hate them because they are difficult to solder and they easily fracture.

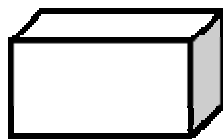

² From M. McWhorter, EE344, High Frequency Laboratory, Chap. 1, Stanford Univ., 1995.

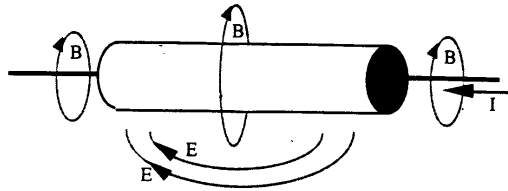

Fig. 1-2: Fields about an ordinary cylindrical resistor [like a carbon composition resistor.]

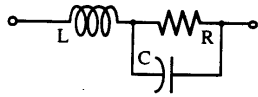

Fig. 1-3: An approximate equivalent circuit for a resistor including parasitic elements.

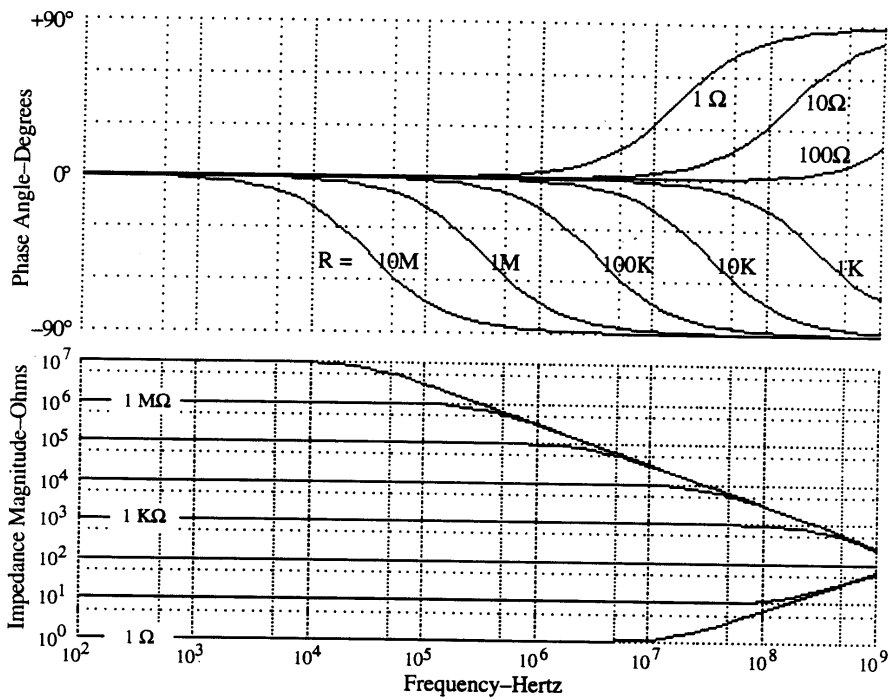

Fig. 1-4: The impedance and phase of various values of a resistor vs frequency. The assumed shunt capacitance is $0.5\ \text{pF}$ and the series inductance is $10\ \text{nH}$.

These come in various sizes. The smaller the size, the better the high frequency performance, but less power can be dissipated, and the soldering gets harder! The standard notation for the physical size of chip components is length-width in 10 mil increments. For example, chip resistors are available in 1206, 0805, 0603, 0402, 0201 dimensions where an 0402 would be 40 x 20 mils (1mm x 0.5mm).

Representative values for parasitic elements of a 1206 chip resistor are $L = 1.2 \text{ nH}$ and $C = 0.03 \text{ pF}$

Capacitors

Capacitors for use in high frequency circuits generally perform one of these roles:

Bypassing	needs to have low impedance over wide frequency range in order to provide a good AC ground
Coupling	blocking of DC between stages
Resonator	frequency control or filter applications
Reactance	used to introduce a pole or zero at a certain complex frequency

Capacitors are made from many different materials, but for high frequency applications, ceramic dielectrics are most frequently used. Some ceramics, however, have large variation of capacitance with temperature (or temperature coefficient, typically in ppm/oC), so care must be exercised in selecting dielectrics when resonators or filters are the application.

Capacitors have the same problem as resistors. When leaded, the self-inductance is often too high to be useful at radio frequencies. They also include some loss, sometimes referred to as ESR or effective series resistance. One possible equivalent circuit is shown below. See Fig. 1-6³ for the frequency dependence of Z .



Since the equivalent circuit of the capacitor looks like a series RLC network, it will have a self-resonant frequency. Above this frequency, it actually behaves like an inductor. This would be a serious deficiency if you were trying to use the capacitor to build an LC filter!

$$\omega = \frac{1}{\sqrt{LC}}$$

³ McWhorter, op. cit.

For example, a 100 pF leaded cap might have a series inductance of 10 nH. That means that it will series resonate at 159 MHz and look like a small real resistance. This is referred to as its *self-resonant frequency or SRF*. If larger C is needed or higher frequency operation is required, then chip capacitors are generally used. These have much lower inductance, typically of the order of 1 nH.

Note that some familiar types of capacitors are not at all effective at high frequencies. They have large inductance. These should be avoided *except for DC supplies, audio frequency applications, and the occasional need for low frequency bypassing on RF amplifiers*. So, in general, for high frequency applications

Avoid: Electrolytic and Tantalum capacitors at high frequencies

Losses in a capacitor tend to be lower than those of an inductor at most all frequencies.

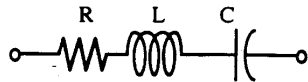
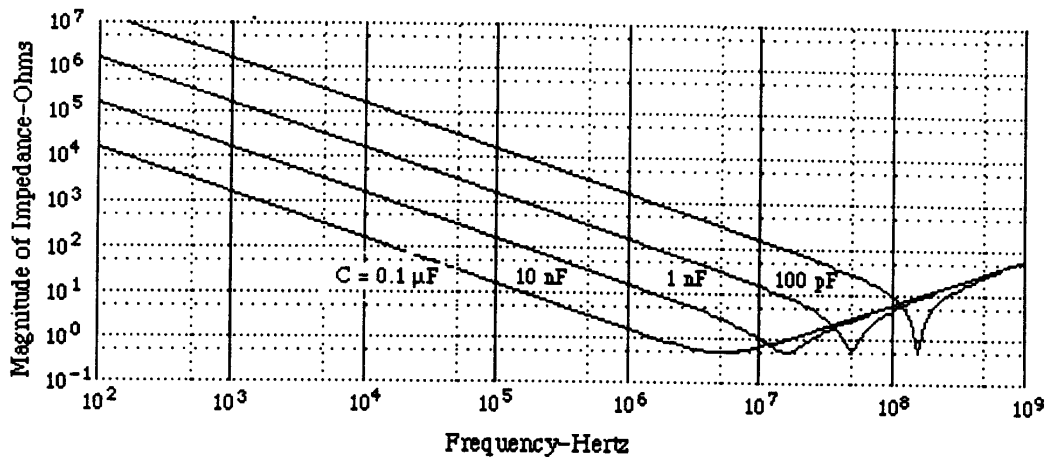
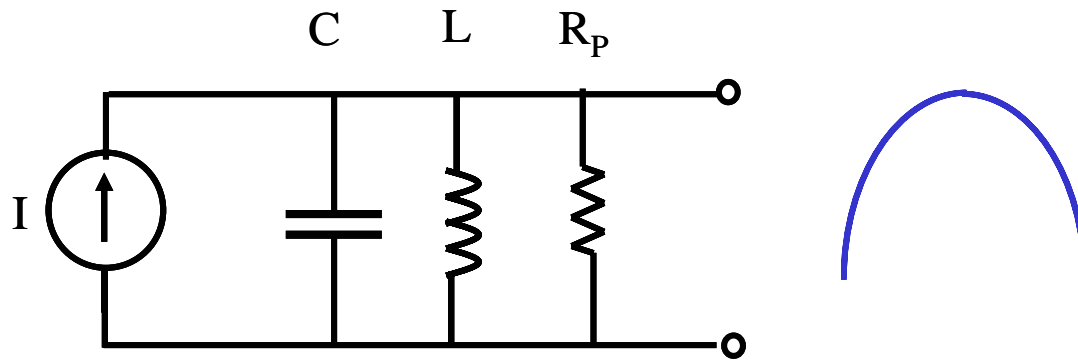

Fig. 1-6: An equivalent circuit for a capacitor.



Resonator example



Below SRF: bandpass response

Well below self-resonant frequency of the capacitor, the network output voltage has a RLC bandpass frequency response. Once the self resonance is exceeded, however, the capacitor exhibits an inductive reactance. As shown below, the circuit now will exhibit a highpass response.

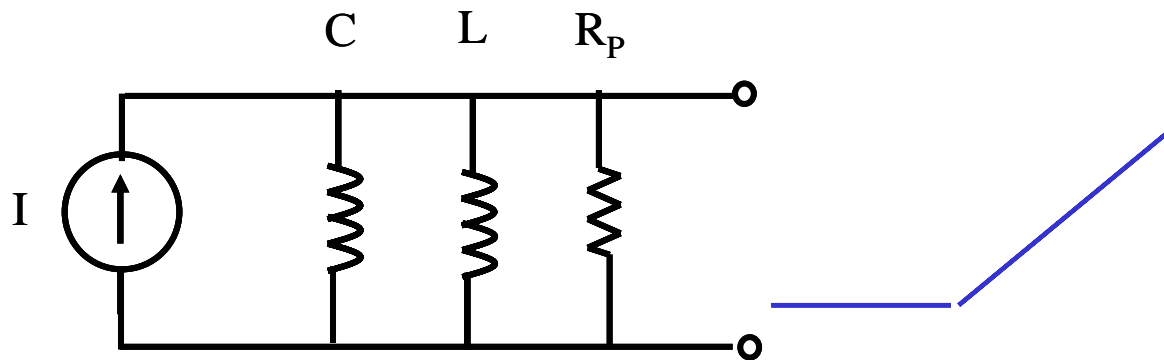

Above SRF of capacitor: highpass response

In both circuits, the R_p represents the resistive losses in the inductor and capacitor components.

Bypass capacitor example

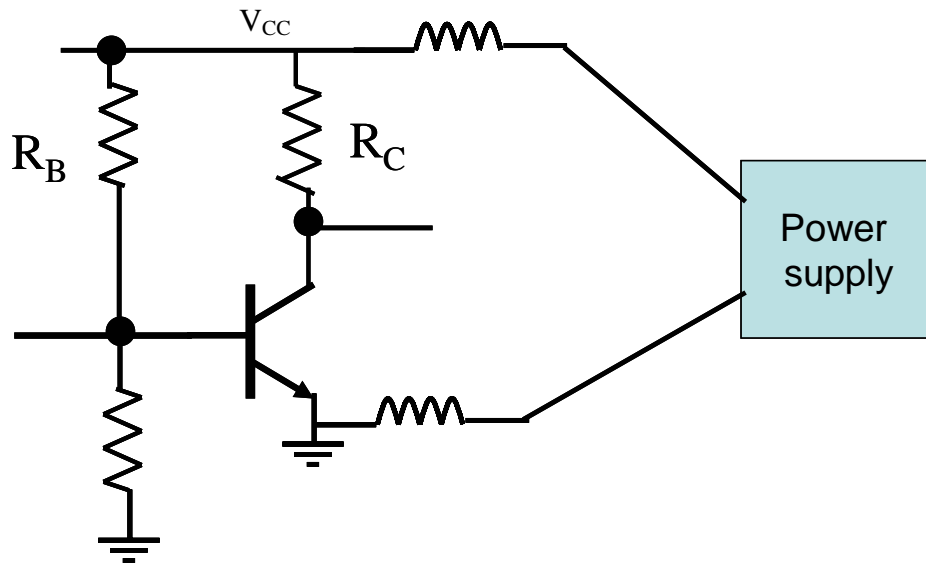

Here is an example of a circuit connected to a power supply without bypass capacitors. The long leads to the supply act like inductors. With only 6 inches of wire, $L = 100$ nH, giving an impedance of $Z = j1600\Omega$ at 1 GHz. Therefore, the V_{CC} node in the circuit is not at AC ground; the impedance seen there increases with frequency. R_B therefore becomes a feedback resistor and reduces the gain of the amplifier.

Worse yet, if several amplifiers are connected to the same supply with no bypass capacitors, the V_{CC} line and ground line act as possible feedback paths from output to input. This makes it highly likely that there will be an oscillation problem that would be very difficult to understand without this bigger picture of the system.

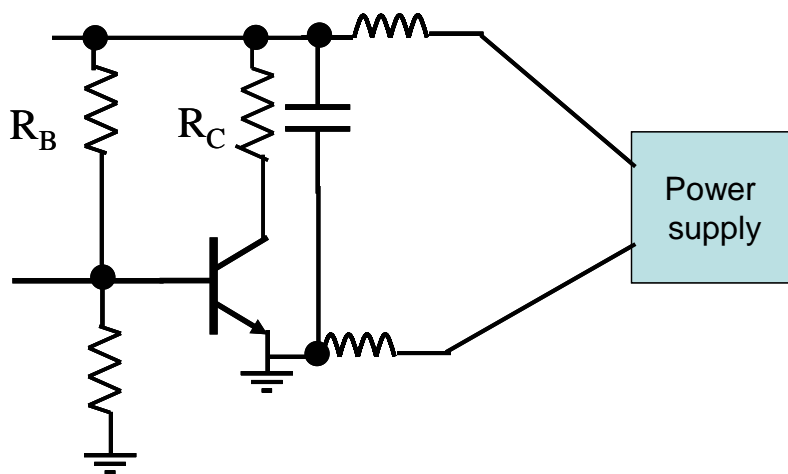

With the addition of a bypass capacitor as shown above, V_{CC} is provided with an AC ground whose impedance decreases with frequency (at least until the SRF is exceeded).

This isolates the supply from the amplifier and the amplifier from other stages in the system.

How do you select the right type, size of bypass C? Choose a value that has a self resonant frequency equal to or higher than the operating frequency of the circuit.

Example: a 0.1 uF leaded capacitor has an inductance of about 10 nH giving a SRF of only 5 MHz. A 100 pF chip cap with L = 1 nH has an SRF = 500 MHz.

Often low impedances are required from the operating frequency down all the way into the kHz region. This requires a cascaded network of bypass capacitors with gradually increasing values, isolated from one another with small inductors or resistors. Or multiple small equal value capacitors can be placed in parallel to increase C while decreasing L.

Another example:

The capacitor is used as a bypass cap in the amplifier circuit below. Plot $|V_{ac}/V_{out}|$ vs frequency. If $V_{out} = 1V$ ac, find the minimum and maximum values of V_{ac} .

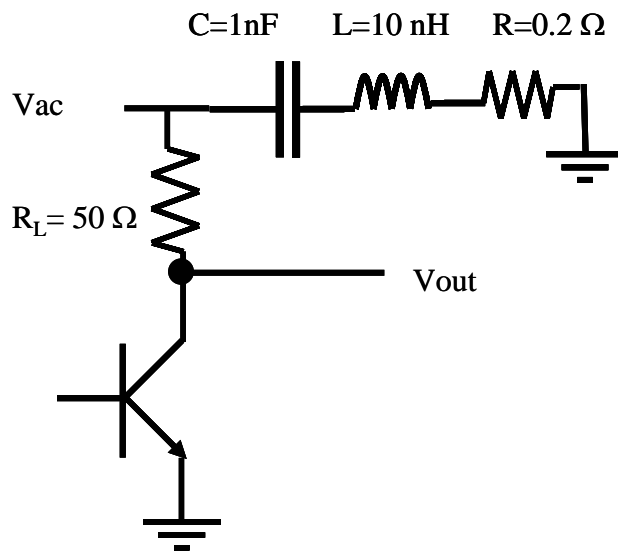

$$\left| \frac{V_{ac}}{V_{out}} \right| = \frac{\sqrt{(\omega RC)^2 + (1 - \omega^2 LC)^2}}{\sqrt{[\omega(R + 50)C]^2 + (1 - \omega^2 LC)^2}}$$

freq	w	R	L	C	Vac/Vout
1.00E+05	6.28E+05	0.2	1.00E-08	1.00E-09	1.00E+00
1.00E+06	6.28E+06	0.2	1.00E-08	1.00E-09	9.54E-01
5.00E+06	3.14E+07	0.2	1.00E-08	1.00E-09	5.32E-01
1.00E+07	6.28E+07	0.2	1.00E-08	1.00E-09	2.91E-01
5.00E+07	3.14E+08	0.2	1.00E-08	1.00E-09	4.08E-03
1.00E+08	6.28E+08	0.2	1.00E-08	1.00E-09	9.31E-02
5.00E+08	3.14E+09	0.2	1.00E-08	1.00E-09	5.26E-01
1.00E+09	6.28E+09	0.2	1.00E-08	1.00E-09	7.80E-01

At very low frequency, the bypass is totally ineffective. $V_{ac,max} = 1$.
 Also, at very high frequency, the inductance dominates, and $V_{ac,max} = 1$.
 $V_{min} = 4e-3$ at series resonance (50 MHz)

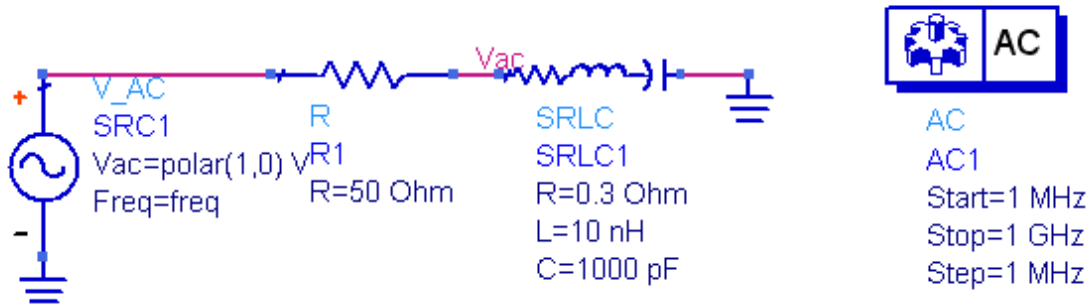

Plot should look something like this.

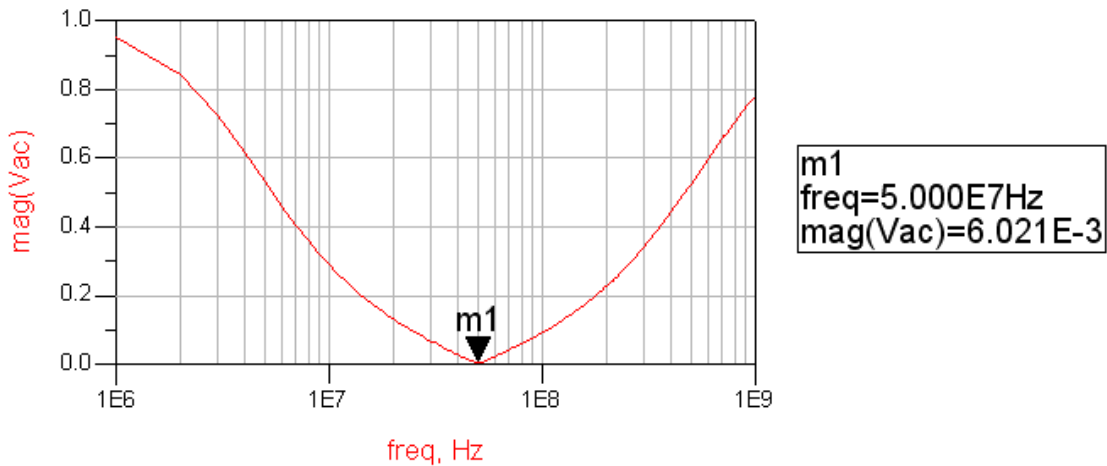

How would you modify the circuit so that the maximum Vac at 10 MHz is less than 1 mV? 1 mV at 100 KHz?

Clearly, the given capacitor, even with many in parallel cannot meet these requirements. One needs to select another capacitor with self resonance at 10 MHz and put at least 6 in parallel to reduce the series resistance down to $R_s < 0.05$ ohm to reduce Vac to 1 mV at 10 MHz.

$$C = \frac{1}{\omega^2 L} = 25 \text{ nF}$$

For 100 KHz, the problem gets harder. One set of capacitors can't give a good bypass at above 10 MHz and at 100 KHz. A two stage bypass network is needed to give better isolation at low frequency. Larger value capacitors (electrolytic or tantalum) can be used at 100 KHz without much concern about inductance. So, an RC lowpass network will work best. If we assume the 1 volt Vout is at 100 KHz, then the filter must provide 60 dB of attenuation. Back of envelope suggests a cutoff frequency of 100 KHz/30 will be needed. Select a combination of R₂ and C₂ that provides this. For example, if R₂ = 10 ohms, then C₂ = 4.7 uF provides a lowpass cutoff frequency of 3.3 KHz.

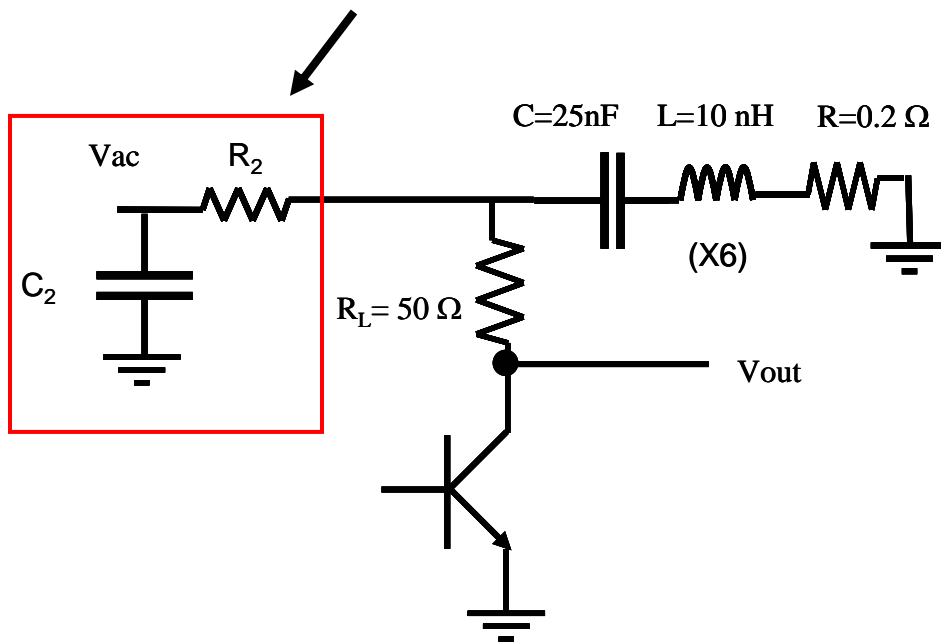

Bypass capacitors. You have seen how wires act as inductors. About 16 nH per inch is typical. Connections to a power supply through wires of any significant length produce a high impedance at radio frequencies. Thus, any illusion that V_{CC} or V_{DD} is at AC ground on the circuit should be rejected. Even with short leads, a typical power supply does not present low output impedance at radio frequencies. Therefore, a local AC ground with low impedance is needed right at the circuit itself to keep the AC signal out of the power supply (V_{CC} or V_{DD}) connection on the circuit board or module or IC chip. This is the function that the bypass capacitor performs.

In order for the capacitor to be effective in attenuating AC signals on the DC voltage line, it must present low impedance at any frequency where the circuit under design exhibits gain. This is to avoid oscillation problems due to an unintended positive feedback loop through the power or ground connection. Thus, the capacitor must be selected so that both real and imaginary parts are small. The series resistance and series inductance are the main factors limiting the effectiveness. Choosing chip capacitors over leaded capacitors helps reduce inductance significantly. Low series resistance (ESR) is also important. Often, identical capacitors are connected in parallel to reduce both L and R while also increasing C.

Using a larger single capacitor is often less effective than using several smaller ones in parallel. This is especially true of electrolytic or tantalum capacitors which have large series inductances. These are fine for low frequency bypassing (below 100 KHz) but worse than useless at radio frequencies. If the bypass impedance must extend to such low frequencies, then a multi-stage bypass is needed that includes both ceramic (low inductance) and electrolytic/tantalum capacitors.

Inductor

Inductors in high frequency circuits generally perform one of the following roles:

RF Choke	Block AC – often used for bias feed
Resonator	frequency control or filter applications
Reactance	used to introduce a pole or zero at a certain complex frequency

As you by now will have anticipated, these are as non-ideal as the other components. An equivalent circuit is shown below:



The series resistance is due to wire IR loss, skin effect losses, radiation, magnetic core material losses (if any) and dielectric losses. Losses in inductors can be quite high. The capacitance in the circuit model is caused by the electric field between turns of the coils of wire since there will be a potential difference between turns. See Fig. 1-9 for the frequency dependence of Z^4 .

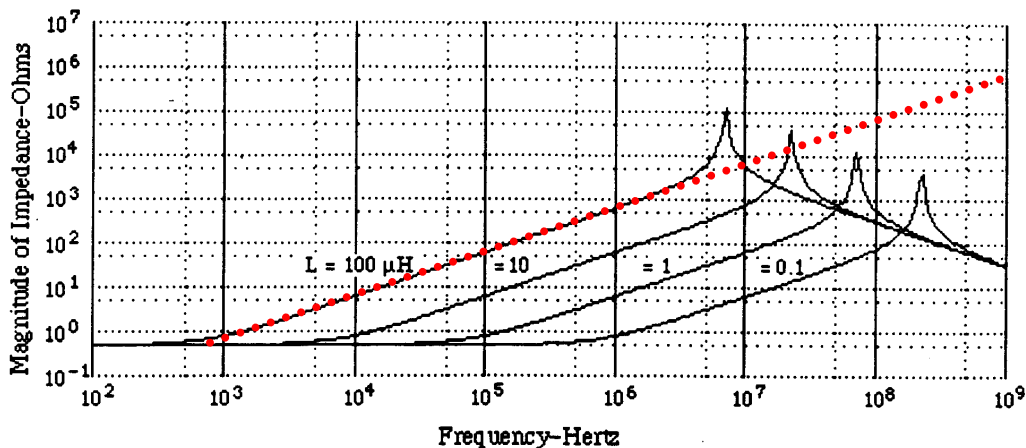

Figure 1.9. The impedance of a typical inductor with frequency. [$R_s = 0.5\Omega$, $C_p = 5\text{ pF}$].
From McWhorter, op cit.

⁴ McWhorter, op. cit.

The inductor also is self-resonant and will exhibit capacitive reactance at high frequencies. This causes the apparent inductance to become quite frequency dependent as you approach the resonant frequency.

RF Choke example

Filter example

Effect of parasitic elements on a presumed lowpass filter structure. (a) as designed, (b) with parasitic elements added, (c) effective circuit above self-resonance of components becomes a high pass. Ref. McWhorter, op. cit.

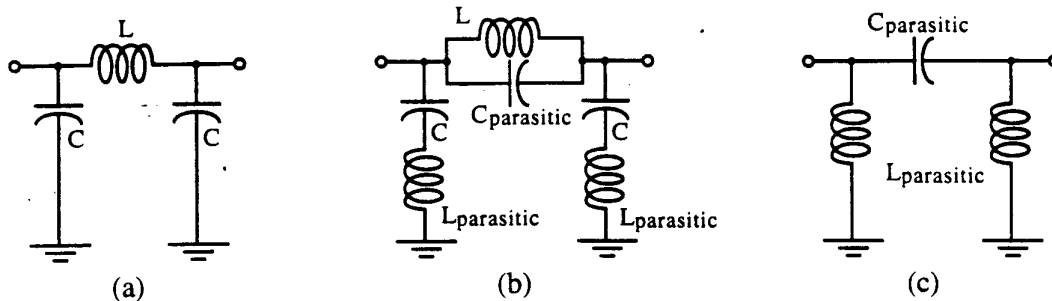

Refer to Bowick again for useful information on constructing inductors from wire.

Quality factor, Q

Reactive components such as capacitors and inductors are often described with a figure of merit called Q. While it can be defined in many ways, it's most fundamental description is:

$$Q = \omega \frac{\text{energy stored}}{\text{average power dissipated}}$$

Thus, it is a measure of the ratio of stored vs. lost energy per unit time. Note that this definition does not specify what type of system is required. Thus, it is quite general. Recall that an ideal reactive component (capacitor or inductor) stores energy

$$E = \frac{1}{2} CV_{pk}^2 \quad \text{or} \quad \frac{1}{2} LI_{pk}^2$$

Since any real component also has loss due to the resistive component, the average power dissipated is

$$P_{avg} = \frac{1}{2} I_{pk}^2 R = \frac{V_{pk}^2}{2R}$$

If we consider an example of a series resonant circuit.

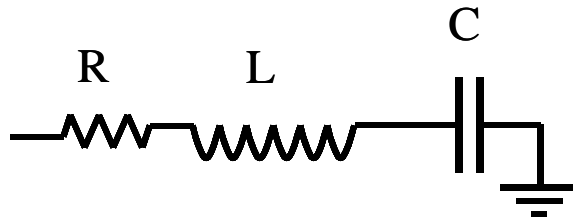

At resonance, the reactances cancel out leaving just a peak voltage, V_{pk} , across the loss resistance, R . Thus, $I_{pk} = V_{pk}/R$ is the maximum current which passes through all elements. Then,

$$Q = \omega_0 \frac{LI_{pk}^2/2}{I_{pk}^2 R/2} = \frac{\omega_0 L}{R} = \frac{1}{\omega_0 RC}$$

In terms of the series equivalent network for a capacitor shown above, its Q is given by:

$$Q = \frac{1}{\omega RC} = \frac{X}{R}$$

where we pretend that the capacitor is resonated with an ideal inductor at frequency ω . X is the capacitive reactance, and R is the series resistance. Since this Q refers only to the capacitor itself, in isolation from the rest of the circuit, it is called unloaded Q . The higher the unloaded Q , the lower the loss. Notice that the Q decreases with frequency.

The unloaded Q of an inductor is given by

$$Q = \frac{\omega L}{R}$$

where R is a series resistance as described above. Note that Q is proportional to frequency for an inductor. The Q of an inductor will depend upon the wire diameter, core material (air, powdered iron, ferrite) and whether or not it is in a shielded metal can.

It is easy to show that for a parallel resonant circuit, the Q is given by:

$$Q = \frac{B}{G}$$

where B is the susceptance of the capacitor or resistor and G is the shunt conductance.

Loaded Q.

When a resonant circuit is connected to the outside world, its total losses (let's call them R_p or G_p) are combined with the source and load resistances, R_s and R_L . For example,

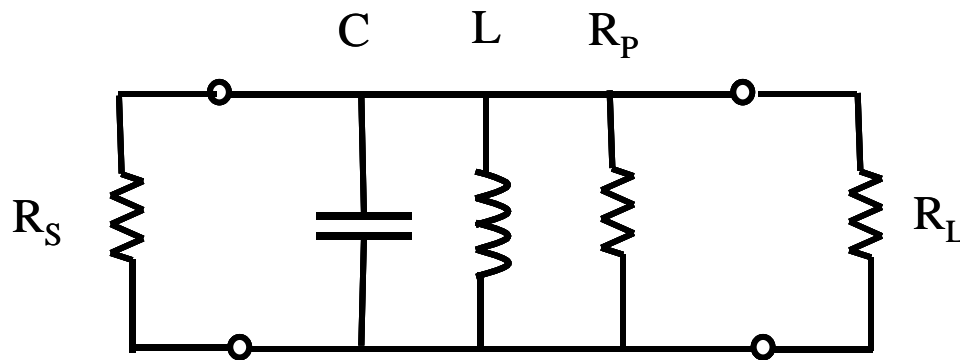

Here is a parallel resonant circuit (C,L and R_p) connected to the outside. The total Q of this circuit is called the loaded Q or Q_L and is given by

$$Q_L = \omega_o C (R_p || R_s || R_L)$$

The significance of this is that Q_L can be used to predict the bandwidth of a resonant circuit. We can see that higher Q_L leads to narrower bandwidth.

$$BW = \frac{\omega_o}{Q_L}$$

Here is an example of a simple resonant circuit. The unloaded Q is infinite, since no losses are included in the network. We see that there is no insertion loss in this case.

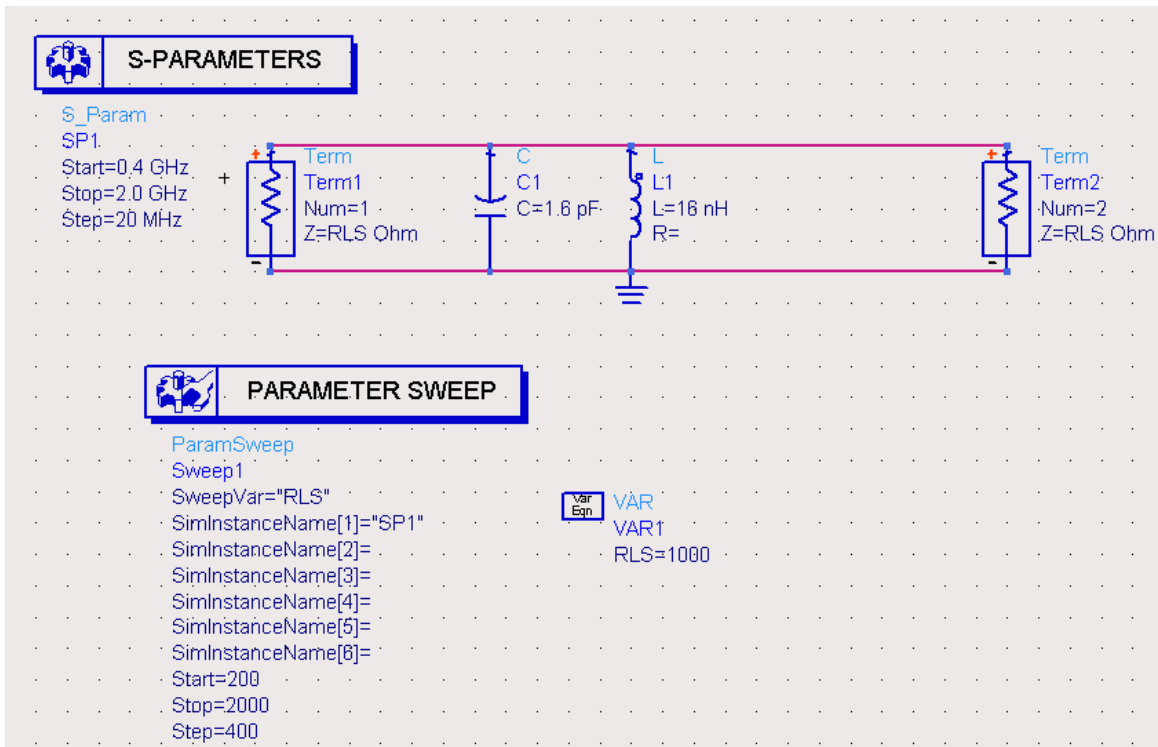

Loaded Q varies from 1 to 10 with the given parameter sweep.

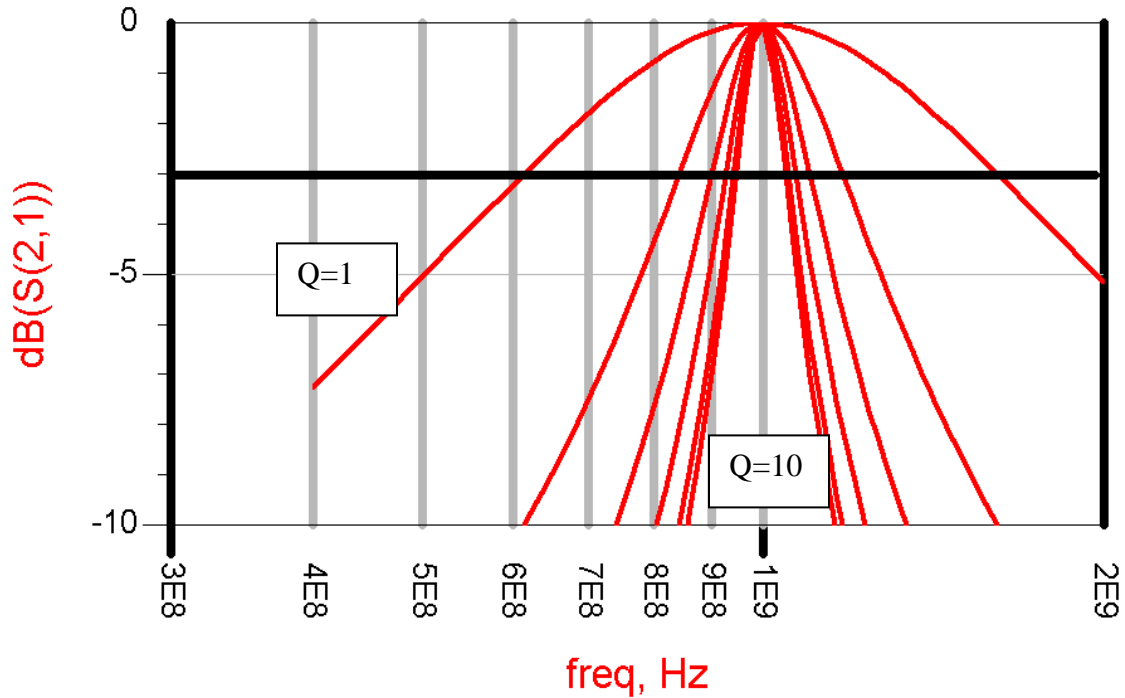

Now, the circuit is modified to include a 500 ohm resistor (R_p) in parallel with the LC network. This resistance represents the parallel equivalent loss due to both the L and the C. So, now we have a finite unloaded Q.

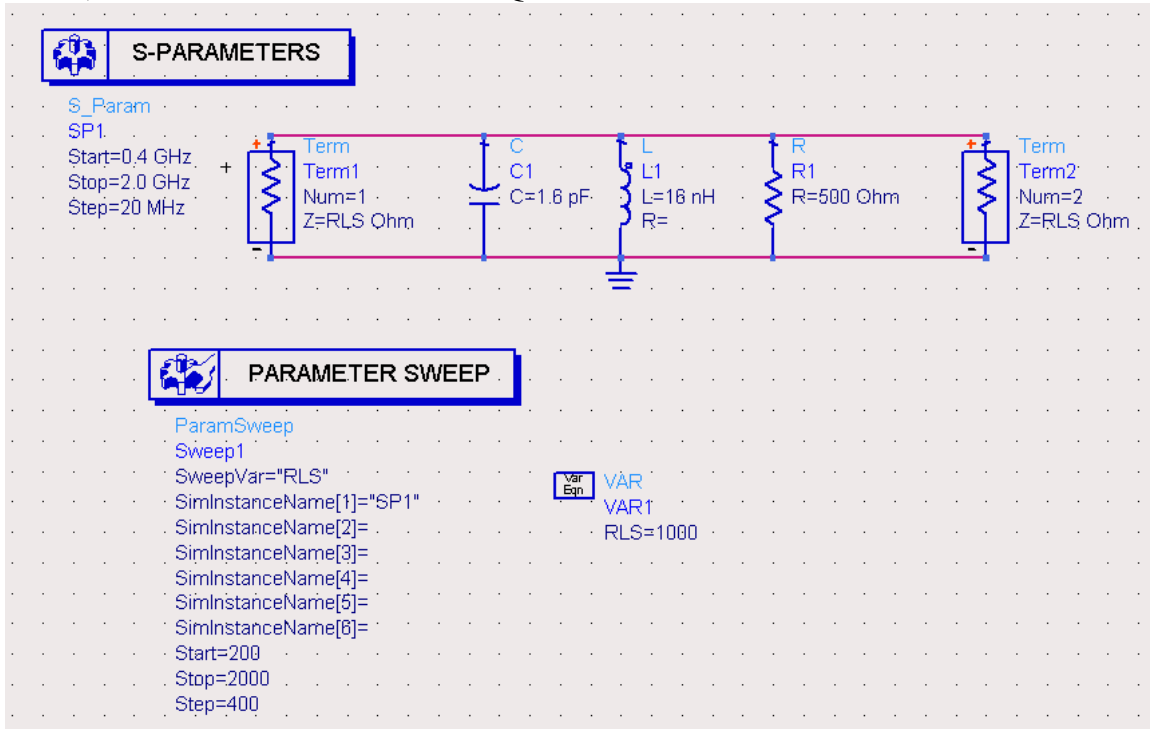

Note that the insertion loss increases as loaded Q, Q_L , approaches Q_U . Sweeping RLS, we see at resonance, the reactances cancel, and we are left with a resistive divider. $V_{out} = V_{in} [R_1 / (2R_1 + R_{LS})]$.

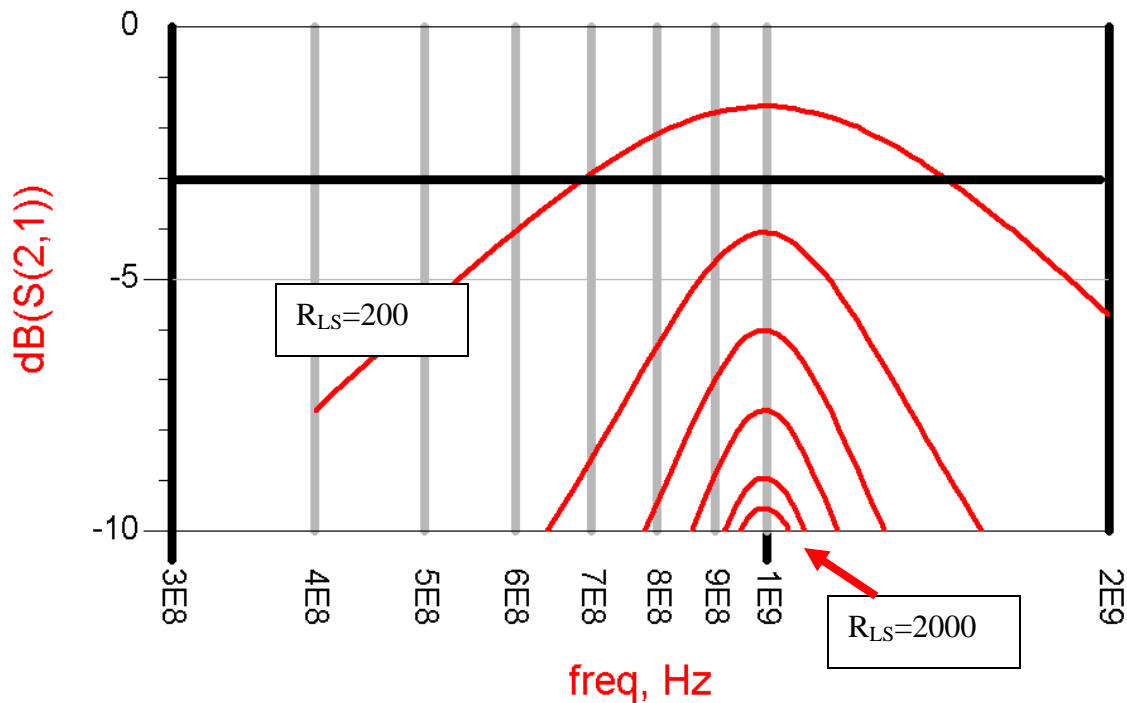

$$S_{21} \text{ (dB)} = 20 \log(2V_{out}/V_{in})$$

Summary

Nonideal Components:

- What you see on the label is not always what you get at high frequencies
- Models are needed at high frequencies for: wires, resistors, capacitors, inductors

Quality Factor (Q) of components and resonant circuits

- Unloaded Q describes the nonideality of individual components.
- Loaded Q includes the source and load resistances from the entire network.
- There is a relationship between loaded Q and bandwidth of second order RLC circuits