

2-Port Parameters

Two-ways of describing device:

A. Equivalent - Circuit-Model

- Physically based
- Includes bias dependence
- Includes frequency dependence
- Includes size dependence - scalability
- Ideal for IC design
- Weakness: Model necessarily simplified; some errors. Thus, weak for highly resonant designs

B. 2-Port Model

- Matrix of tabular data vs. frequency
- Need one matrix for each bias point and device size
- Clumsy – huge data sets required
- Traditional microwave method
- Exact

2 Port descriptions

These are black box (mathematical) descriptions.

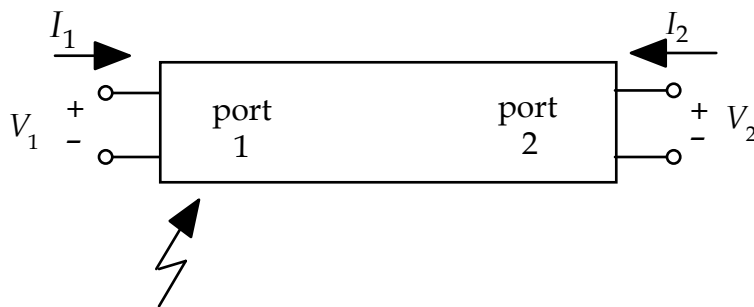

Inside might be a transistor, a FET, a transmission line, or just about anything.

The terminal characteristics are V_1 V_2 I_1 & I_2 – there are 2 degrees of freedom.

Admittance Parameters

$$\begin{bmatrix} I_1 \\ I_2 \end{bmatrix} = \begin{bmatrix} Y_{11} & Y_{12} \\ Y_{21} & Y_{22} \end{bmatrix} \begin{bmatrix} V_1 \\ V_2 \end{bmatrix}$$

Example: Simple FET Model

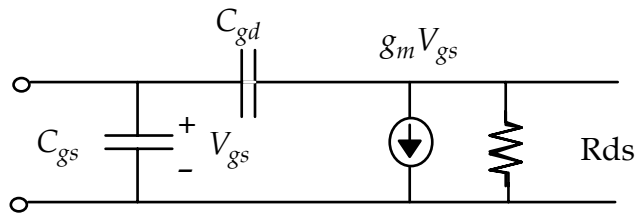

By inspection:

$$Y = \begin{bmatrix} j\omega C_{gs} + j\omega C_{gd} & -j\omega C_{gd} \\ g_m - j\omega C_{gd} & G_{ds} + j\omega C_{gd} \end{bmatrix}$$

Easy!

$$Y_{11} = \left. \frac{I_1}{V_1} \right|_{V_2=0} \quad Y_{12} = \left. \frac{I_1}{V_2} \right|_{V_1=0}$$

Impedance Parameters

$$\begin{bmatrix} V_1 \\ V_2 \end{bmatrix} = \begin{bmatrix} Z_{11} & Z_{12} \\ Z_{21} & Z_{22} \end{bmatrix} \begin{bmatrix} I_1 \\ I_2 \end{bmatrix}$$

Example

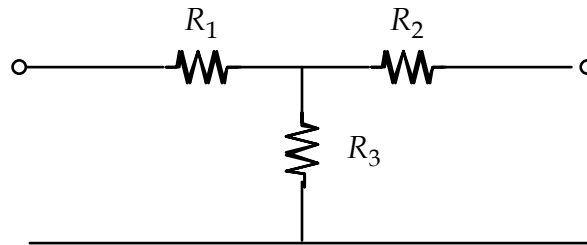

By inspection

$$Z = \begin{bmatrix} R_1 + R_3 & R_3 \\ R_3 & R_2 + R_3 \end{bmatrix}$$

$$Z_{11} = \left. \frac{V_1}{I_1} \right|_{I_2=0} \quad Z_{21} = \left. \frac{V_2}{I_1} \right|_{I_2=0}$$

But, y , z , and h parameters are not suitable for high frequency measurement.

Problem: How can you get a true open or short at the circuit terminals? Any real short is inductive. Any real open is capacitive.

To make matters worse, if you are trying to measure a high freq. active device, a short or open can make it oscillate!

Solution: Use termination in Z_0 instead!

Broadband.

Not very sensitive to parasitic L,C

Kills reflections.

Redefine parameters to use fwd. and rev. voltage waves.

Measurement can use directional couplers.

S-Parameters

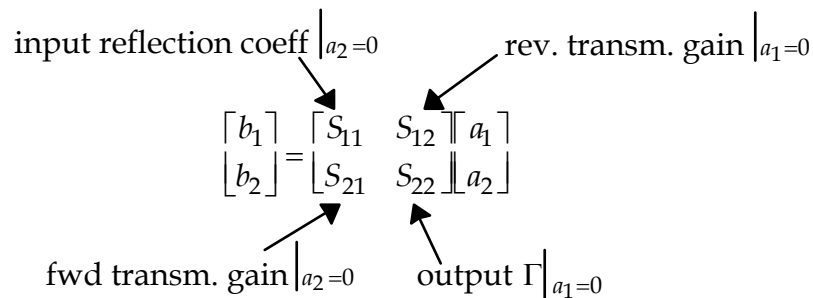
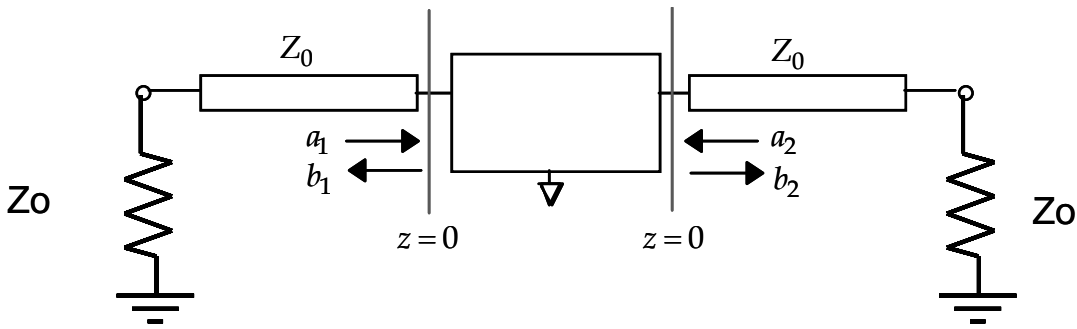

Note that Z_0 must be defined. We don't really need transmission lines.

Our objective now is to de-mystify S-parameters – they are easy!

Recall

$$V(x) = V^+(x) + V^-(x) \quad \text{phasor quantities.}$$

$$I(x) = \frac{V^+(x)}{Z_0} - \frac{V^-(x)}{Z_0} \quad \text{amplitude, not rms values.}$$

We can normalize the amplitude of waves to Z_0 :

$$a(x) = \frac{V^+(x)}{\sqrt{Z_0}} \quad \text{forward wave}$$

$$b(x) = \frac{V^-(x)}{\sqrt{Z_0}} \quad \text{reverse wave}$$

Why? So that $\frac{1}{2} a(x)a^*(x) = \text{power in forward wave.}$

if $a = 1.414$ then power in wave is 1 watt. (or $a_{rms} = 1$)

likewise, $b(x)b^*(x)/2$ is the power in the reverse wave

So, in terms of total voltage $V(x)$ and current $I(x)$,

$$v(x) = \frac{V(x)}{\sqrt{Z_0}} = a(x) + b(x)$$

$$i(x) = \sqrt{Z_0} I(x) = a(x) - b(x)$$

or,

$$a(x) = \frac{1}{2} [v(x) + i(x)] = \frac{1}{2\sqrt{Z_0}} [V(x) + Z_0 I(x)]$$

$$b(x) = \frac{1}{2} [v(x) - i(x)] = \frac{1}{2\sqrt{Z_0}} [V(x) - Z_0 I(x)]$$

Reflection

So, how is Γ defined in terms of the S parameters? At port 1,

$$\Gamma_1 = \frac{b_1}{a_1}$$

But,

$$b_1 = S_{11}a_1 + S_{12}a_2$$

We need to eliminate a_2 . How?

If $Z_L = Z_0$, $\Gamma_L = 0 = \frac{a_2}{b_2}$ so, therefore $a_2 = 0$ if port 2 is terminated in Z_0 .

$$\Gamma_1 = \left. \frac{b_1}{a_1} \right|_{a_2=0} = S_{11}$$

Same with at port 2 with S_{22} :

$$S_{22} = \left. \frac{b_2}{a_2} \right|_{a_1=0} = \Gamma_2$$

Transmission

$$b_2 = S_{21}a_1 + S_{22}a_2$$

So, the forward transmission S_{21} can be found by setting $a_2 = 0$ (terminate output)

$$S_{21} = \left. \frac{b_2}{a_1} \right|_{a_2=0}$$

Reverse transmission, similarly, is found by setting $a_1 = 0$ (terminate input in Z_o)

$$b_1 = S_{11}a_1 + S_{12}a_2$$

$$S_{12} = \left. \frac{b_1}{a_2} \right|_{a_1=0}$$

Some comments on power measurement:

Power can vary over a large range, therefore it is often specified on a logarithmic scale. There must be a point of reference on the scale; the power measurements are usually with reference to 1 mW.

The unit is called dBm meaning dB relative to 1 mW of power. Thus,

$$\begin{aligned} 0 \text{ dBm} &= 1 \text{ mW} \\ 10 \text{ dBm} &= 10 \text{ mW} \\ -10 \text{ dBm} &= 0.1 \text{ mW} \\ &\text{etc.} \end{aligned}$$

To convert mW to dBm:

$$dBm = 10 \log_{10} (P)$$

To convert dBm to mW:

$$P = 10^{dBm/10}$$

What is the difference between dB and dBm?

dB is a power ratio – used to describe a gain or loss for example.

$$\begin{aligned} G &= 10 \log_{10} (P_{out}/P_{in}) && \text{dB} \\ \text{Return Loss} &= -20 \log_{10} |\Gamma| && \text{dB} \end{aligned}$$

But, dB says nothing about the absolute power level. Don't confuse their usage!

Now, define available power:

$P_{AVS} = \underline{\text{max power output from a source with impedance } Z_S \text{ that can be absorbed into a load.}}$

let $Z_S = Z_0, Z_L = Z_S^* = Z_0$ (in this case)

because maximum power transfer occurs when we have a conjugate match

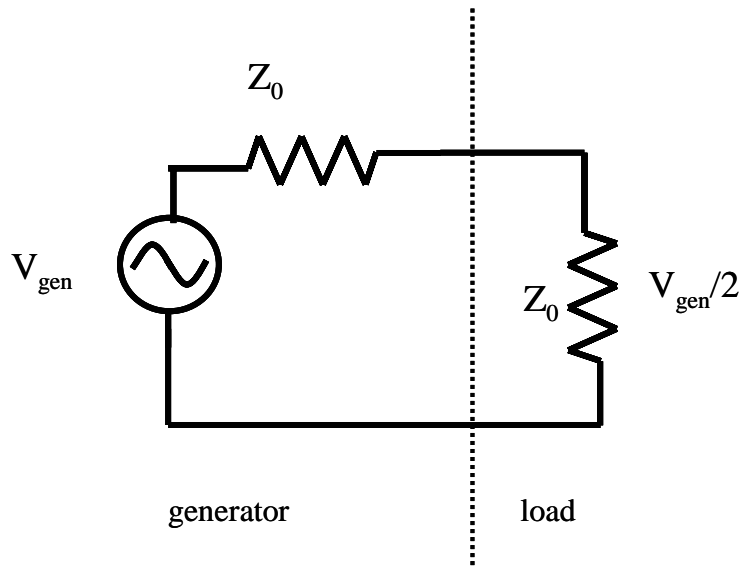

$$P_{load} = P_{AVS} = \frac{1}{8} \frac{V_{gen}^2}{Z_0}$$

Or, in terms of a and b:

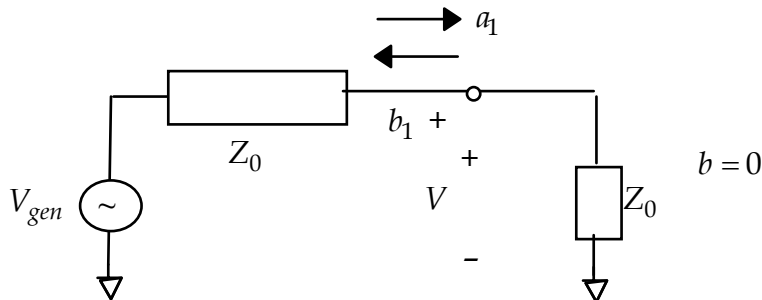

$$a_1 = \frac{V^+}{\sqrt{Z_0}} \text{ and } b_1 = 0; \quad V^+ = V_{gen} \left(\frac{Z_0}{Z_0 + Z_0} \right) = \frac{V_{gen}}{2} \text{ and } V^- = 0$$

So,

$$P_{load} = P_{AVS} = \frac{1}{2} a_1 a_1^* = \frac{V_{gen}^2}{8Z_0}$$

- ❖ We see that the available power is independent of load impedance. Even if the load is not matched, available power remains constant. Actual power in the load is reduced however.
- ❖ Generator output power is calibrated and displayed as available power.

Actual Load Power

$$P_{\text{Load}} = \frac{1}{2}|a_1|^2 - \frac{1}{2}|b_1|^2 = \frac{1}{2}\text{Re}[I_1 V_1^*]$$

or

$$P_{\text{Load}} = P_{\text{AVS}}(1 - |S_{11}|^2)$$

Reflected Power

$$b_1 = a_1 S_{11}$$

$$P_R = \frac{1}{2}|b_1|^2 = \frac{1}{2}|a_1|^2 |S_{11}|^2 = P_{\text{AVS}} |S_{11}|^2$$

$$|S_{11}|^2 = \frac{\text{Power reflected from input}}{\text{Power incident on input}} = \frac{|b_1|^2}{|a_1|^2}$$

$$|S_{22}|^2 = \frac{\text{Power reflected from network output}}{\text{Power incident on output}} = \frac{|b_2|^2}{|a_2|^2}$$

Similarly,

$$\begin{aligned} \frac{1}{2}|a_2|^2 &= \text{Power incident on output} \\ &= \text{Reflected power from load} \end{aligned}$$

$$\frac{1}{2}|b_1|^2 = \text{Power reflected from input port}$$

$$\frac{1}{2}|b_2|^2 = \text{Power incident on load from the network}$$

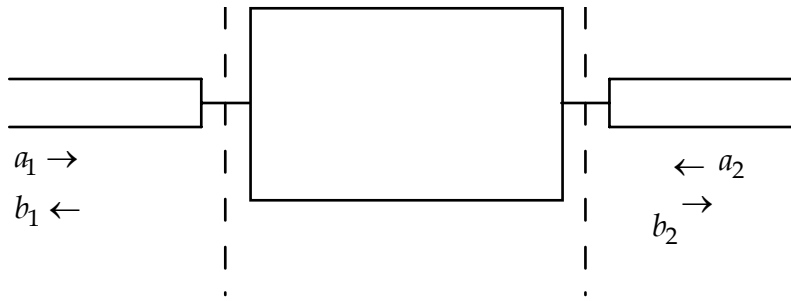

Also, by definition, transducer gain = $\frac{P_{\text{load}}}{P_{\text{avs}}} = G_T$ even if

1. load isn't matched to network and
2. input of network not matched to generator

Here, $P_{\text{Load}} = |b_2|^2 (1 - |\Gamma_L|^2)$

S_{21} is defined in terms of transducer gain for the special case of where $Z_L = Z_0$:

$$|S_{21}|^2 = \left. \frac{|b_2|^2}{|a_1|^2} \right|_{a_2=0}$$

$\frac{1}{2}|b_2|^2 =$ power incident on load (and is absorbed since $\Gamma_L=0$)

$\frac{1}{2}|a_1|^2 =$ source available power

$|S_{21}|^2 =$ transducer gain with source and load Z_0

Similarly,

$|S_{12}|^2 =$ reverse transducer power gain

Reference Planes

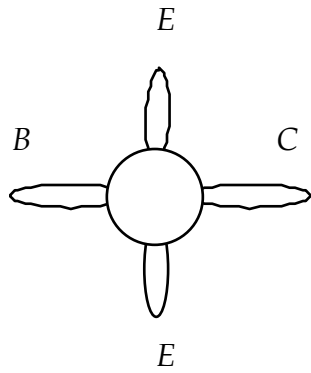

Microwave transistor in package

On board:

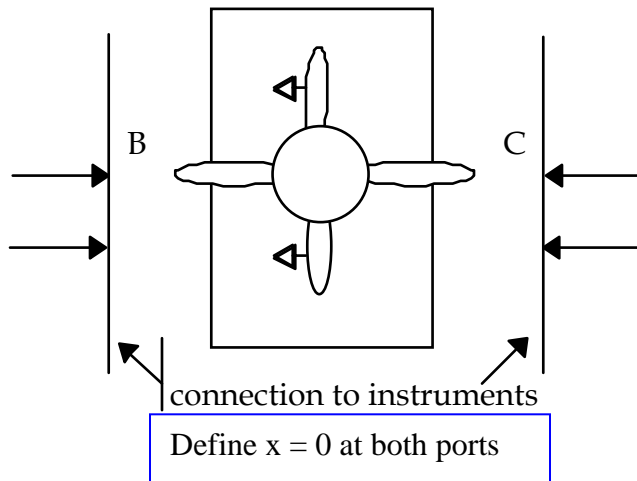

$$[S] = \begin{bmatrix} S_{11} & S_{12} \\ S_{21} & S_{22} \end{bmatrix}$$

Defining the reference planes differently changes the S-parameters.

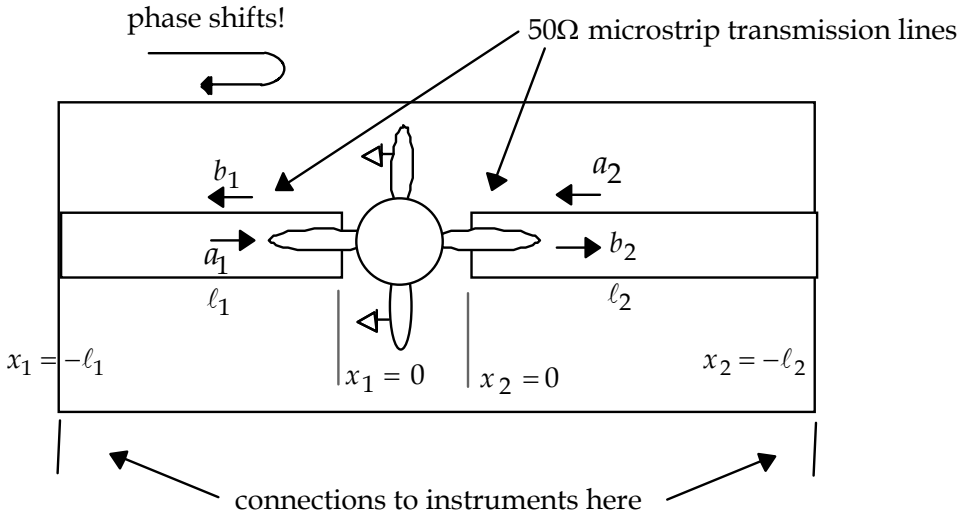

$$\theta_1 = \beta x_1 = -\frac{2\pi\ell_1}{\lambda}$$

$$\theta_2 = \beta x_2 = -\frac{2\pi\ell_2}{\lambda}$$

$$S' = \begin{pmatrix} S_{11} e^{2\theta_1} & S_{12} e^{j(\theta_1+\theta_2)} \\ S_{21} e^{j(\theta_1+\theta_2)} & S_{22} e^{j2\theta_2} \end{pmatrix}$$

The reflection parameters are shifted in phase by twice the electrical length because the incident wave travels twice over this length upon reflection. The transmission parameters have the sum of the electrical lengths, since the transmitted wave must pass through both lengths.

Comment on electrical length:

The microwave literature will say a line is 43° long at $\underbrace{5 \text{ GHz}}_{f_{ref}}$. What does this mean?

$$\text{Electrical length} = E = \frac{\ell}{\lambda_{ref}} \cdot 360^\circ$$

$$\text{Recall } f \cdot \lambda = v \text{ so } f_{ref} \lambda_{ref} = v$$

$$\rightarrow E = \frac{\ell}{v/f_{ref}} \cdot 360^\circ = \frac{\ell}{v} \cdot f_{ref} \cdot 360^\circ$$

$$E = T \cdot f_{ref} \cdot 360^\circ$$

a line which is 1 ns long has an electrical length $E = 360^\circ$ at $f_{ref} = 1 \text{ GHz}$

and

an electrical length $E = 36^\circ$ at $f_{ref} = 100 \text{ MHz}$

Why not just say $T = 1 \text{ ns}$?

...you should be conversant with **both** terminologies.

Converting to physical length

$$f \lambda_{ref} = v_p$$

$$\lambda_{ref} = \frac{v_p}{f}$$

$$\text{thus: } \text{physical length} = \frac{E(\text{deg})\lambda_{ref}}{360} = \text{Electrical length (in wavelengths)} \lambda_{ref}$$

or:

How to Calculate S-Parameters Quickly

First Comment

$$S_{11} = \left. \frac{b_1}{a_1} \right|_{a_2=0}$$

$$b_1 = S_{11}a_1 + S_{12}a_2$$

(We must kill a_2 in order to measure or calculate S_{11})

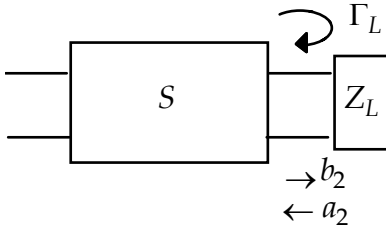

if $Z_L = Z_0$, then Γ_L is zero

and so $a_2 = \Gamma_L b_2 = 0$.

So

$$S_{11} = \left. \frac{b_1}{a_1} \right|_{Z_L=Z_0}$$

So if we say that $Z_{in}|_{Z_L=Z_0}$ is the input impedance with $Z_0 = Z_L$

then

$$S_{11} = \frac{Z_{in}|_{Z_L=Z_0} - Z_0}{Z_{in}|_{Z_L=Z_0} + Z_0} = \Gamma_{in}$$

or:

$$Z_{in}|_{Z_L=Z_0} = \frac{1 + S_{11}}{1 - S_{11}}$$

The same comment clearly applies for S_{22} . The Smith Chart is often used to plot S_{11} , S_{22} .

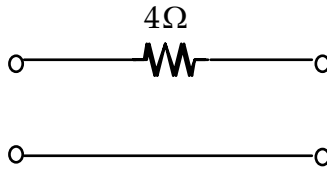
Example:

Given $Z_0 = 50\Omega$, what is S_{11} ?

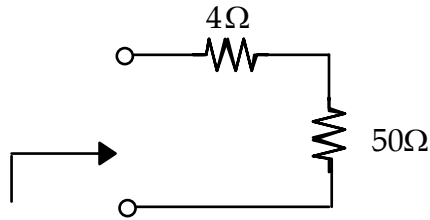

$$Z_{in}|_{Z_L=Z_0} = 54\Omega$$

$$S_{11} = \frac{54 - 50}{54 + 50} = \frac{4}{104}$$

Similar arguments give $S_{22} = \frac{4}{104}$.

Find S_{21}

$$S_{21} = \frac{b_2}{a_1} |_{a_2=0}$$

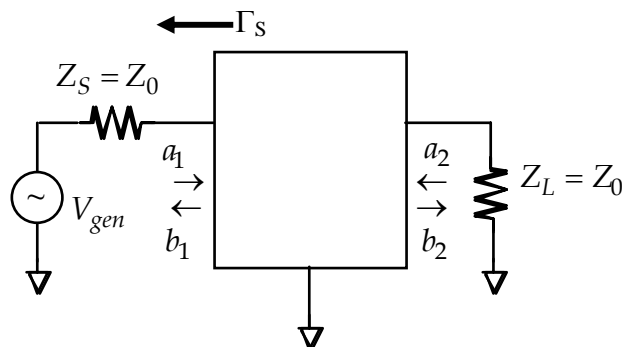

What is a_1 in this case?

We know that: $a_1 = \frac{V_1^+}{\sqrt{Z_0}}$ and $V_1^+ = \frac{V_{gen}}{2}$

So,

$$a_1 = \frac{V_{gen}}{2\sqrt{Z_0}}$$

Consider the load:

$$b_2 = \frac{V_{out}}{\sqrt{Z_0}} \quad \text{Why?}$$

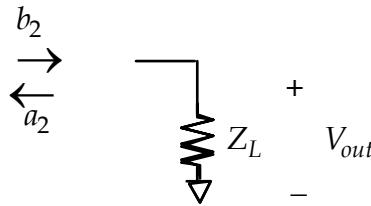

$$a_2 = \Gamma_L b_2$$

But, $\Gamma_L = 0$ because $Z_L = Z_0$, so $a_2 = 0$.

$$\begin{aligned} V_{out} &= V^+ + V^- = \sqrt{Z_0} a_2 + \sqrt{Z_0} b_2 \\ &= \sqrt{Z_0} b_2 \end{aligned}$$

Now, calculate V_{out}/V_{gen} :

$$V_{out} = \sqrt{Z_0} b_2 = \sqrt{Z_0} (S_{21}a_1 + S_{22}a_2)$$

But, $a_2 = 0$ because the load impedance = Z_0 , so

$$V_{out} = \sqrt{Z_0} S_{21} a_1$$

Substitute for a_1 :

$$a_1 = \frac{V_{gen}}{2\sqrt{Z_0}}$$

so,

$$\frac{V_{out}}{V_{gen}} = \frac{\sqrt{Z_0} S_{21}}{2\sqrt{Z_0}} = \frac{S_{21}}{2}$$

thus, $S_{21} = \frac{2V_{out}}{V_{gen}}$ when $Z_L = Z_S = Z_0$

Why the factor of 2?

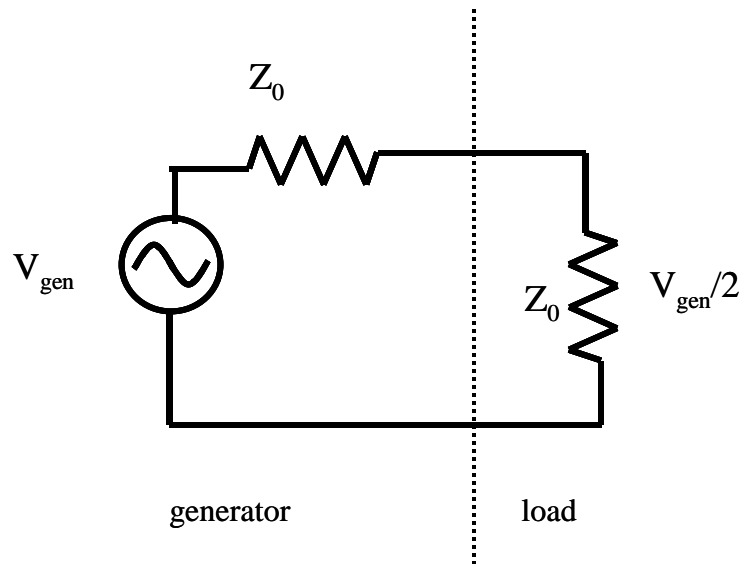

We see that the generator voltage is split between the source and load in the matched case. Here, we see that $V_{out}/V_{gen} = 1/2$, but the transducer gain must be equal to 1. (P_{LOAD}/P_{AVS}) . $|S_{21}|^2$ is the transducer gain in this situation. If we insert an amplifier into the network, the signal has been increased by an amount S_{21} .

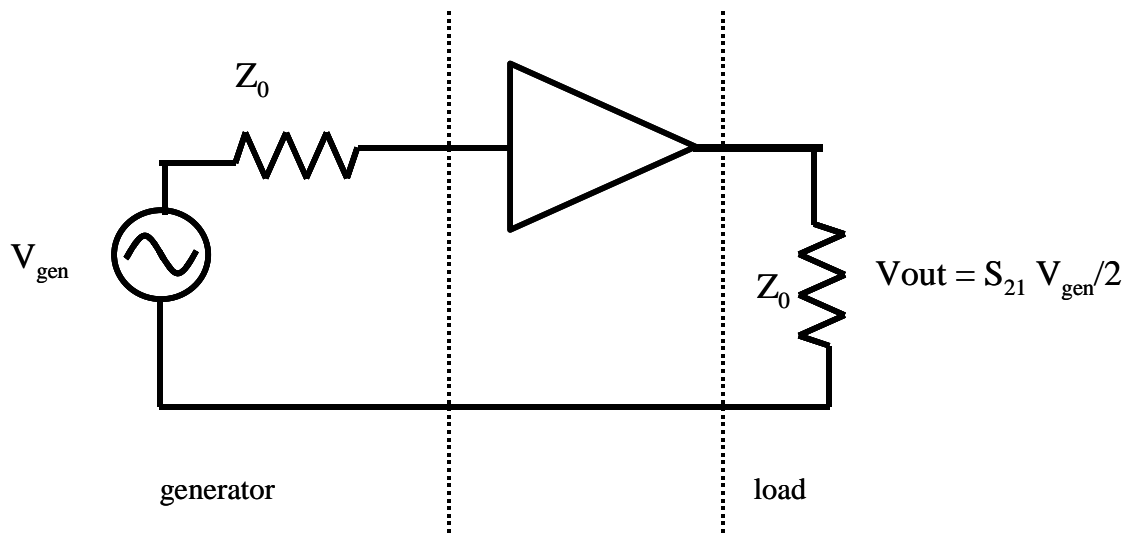

So, $|S_{21}|^2$ is the FORWARD INSERTION GAIN or FORWARD TRANSDUCER GAIN in a system of impedance Z_0 .

EXAMPLE: Find S_{21}

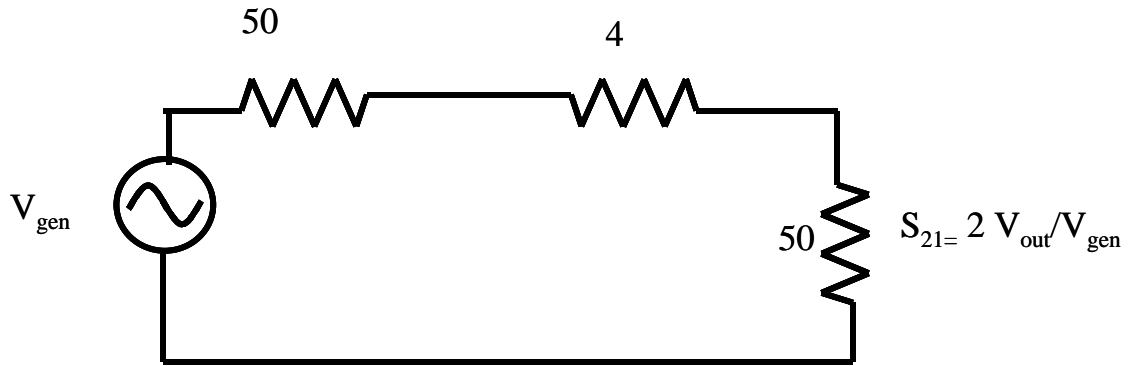

$$V_{out}/V_{gen} = 50/104 = 0.48$$

$$S_{21} = 0.96$$

OR, we could let $V_{gen} = 2$. Then, $S_{21} = V_{out}$.

What about a reference plane extension?

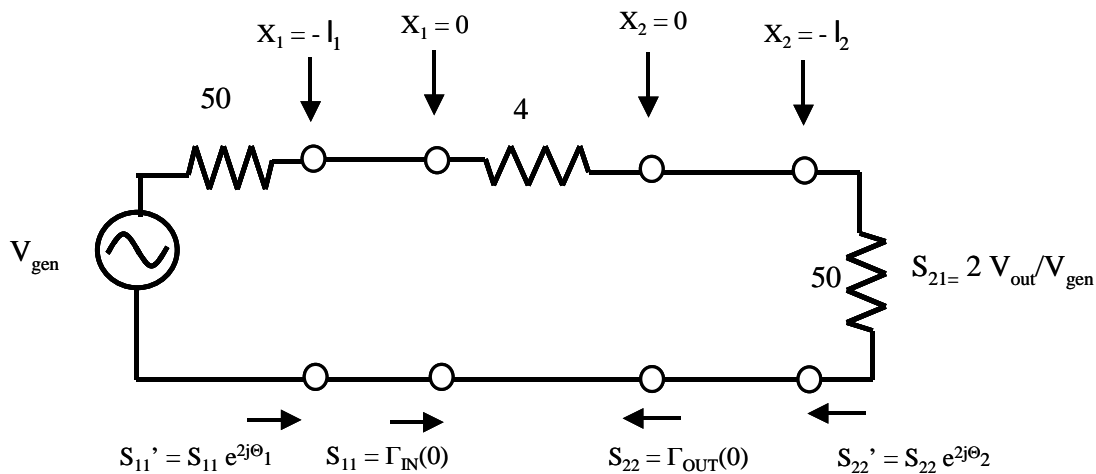

and

$$\theta_1 = -\beta l_1 = -\frac{2\pi}{\lambda} l_1 \quad \theta_2 = -\beta l_2 = -\frac{2\pi}{\lambda} l_2$$

$$S'_{21} = S_{21} e^{j(\theta_1 + \theta_2)} = S_{21} e^{-2\pi j(l_1 + l_2)/\lambda}$$

EXAMPLE: Find the 4 S parameters of the following circuit:

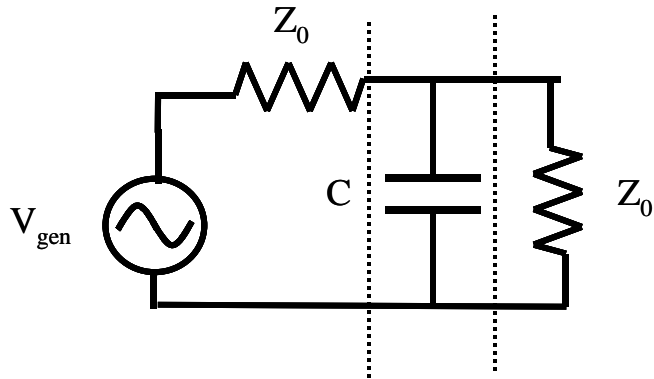

S_{11} : Find Z_{in} (with $Z_L = Z_0$), then calculate input reflection coefficient.

$$Z_{\text{IN}}|_{Z_L=Z_0} = 1 / (sC + 1/Z_0)$$

$$S_{11} = \frac{Z_{\text{IN}} - Z_0}{Z_{\text{IN}} + Z_0} = \frac{Z_{\text{IN}}/Z_0 - 1}{Z_{\text{IN}}/Z_0 + 1}$$

turning the crank,

$$S_{11} = \frac{-j\omega CZ_0 / 2}{1 + j\omega CZ_0 / 2}$$

S_{22} will be the same due to symmetry. Note that we calculated Z_{IN} with port 2 terminated in Z_0 . This is part of the definition of S_{11} so is essential.

Now find S_{21} : first use Thevenin – Norton transformation:

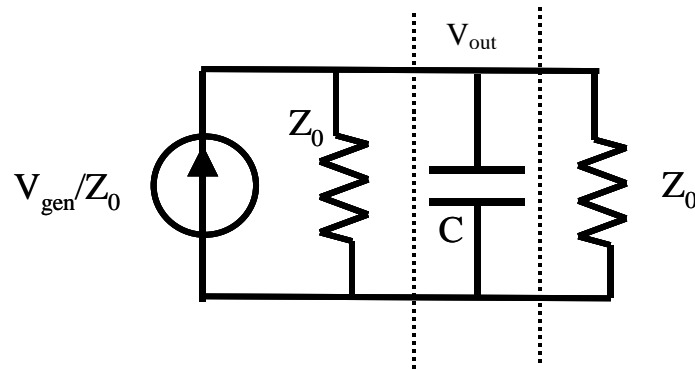

$$V_{out} = \frac{V_{gen}}{Z_0} \frac{1}{\frac{2}{Z_0} + sC} = I/Y$$

$$S_{21} = \frac{2V_{out}}{V_{gen}} = \frac{1}{1 + j\omega CZ_0/2} = S_{12}$$