

## Small Signal AC analysis of oscillator - open loop

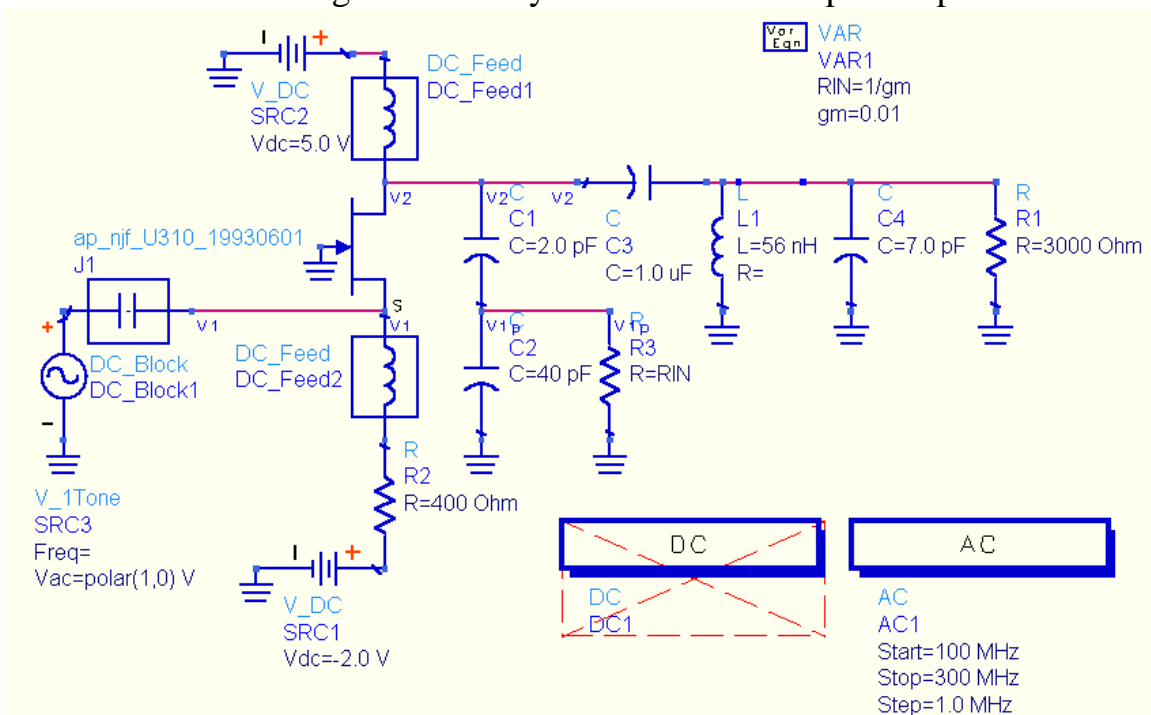

Here is an example using a JFET in a CG configuration. AC small signal analysis is used to evaluate the startup condition. The loop is broken between the source (V1), the input to the loop and the capacitor tap, V1p, the output of the loop. The output is loaded with a resistor that emulates the loading seen at the source of the JFET,  $1/g_m$ . Any additional load resistance could also be added here – for the input to a buffer stage, for example.  $R_1$  is derived from the unloaded  $Q$  of the inductor:

$$Q_u = \frac{B}{G} = \frac{1/\omega L}{1/R_1} = \frac{R_1}{\omega L}$$

For higher accuracy, the CGS of the JFET should be added in parallel with  $C_2$  for this simulation. This will reduce the resonant frequency slightly.

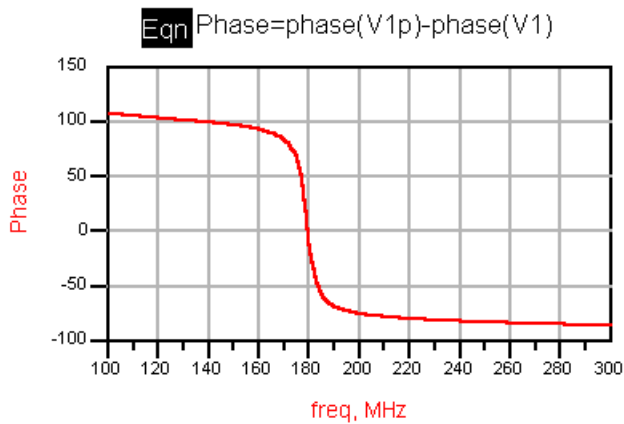
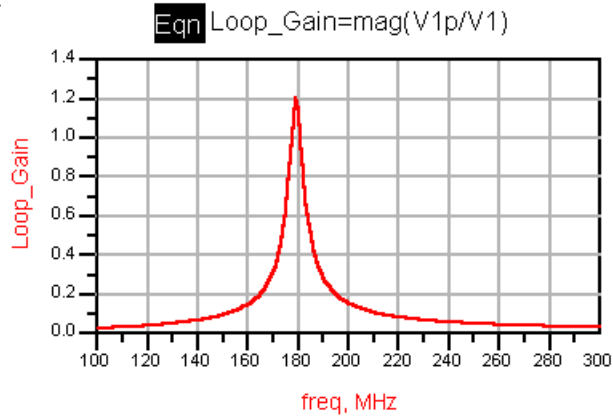

Here we see the result of the frequency sweep. The peak loop gain occurs at 179 MHz as does the 0 degree phase shift point. The oscillator should start up at this frequency. Note that the loop gain is rather low for reliable startup. The tapped capacitor impedance transformer should be revised for higher small signal loop gain.

## Transient Analysis of Oscillator

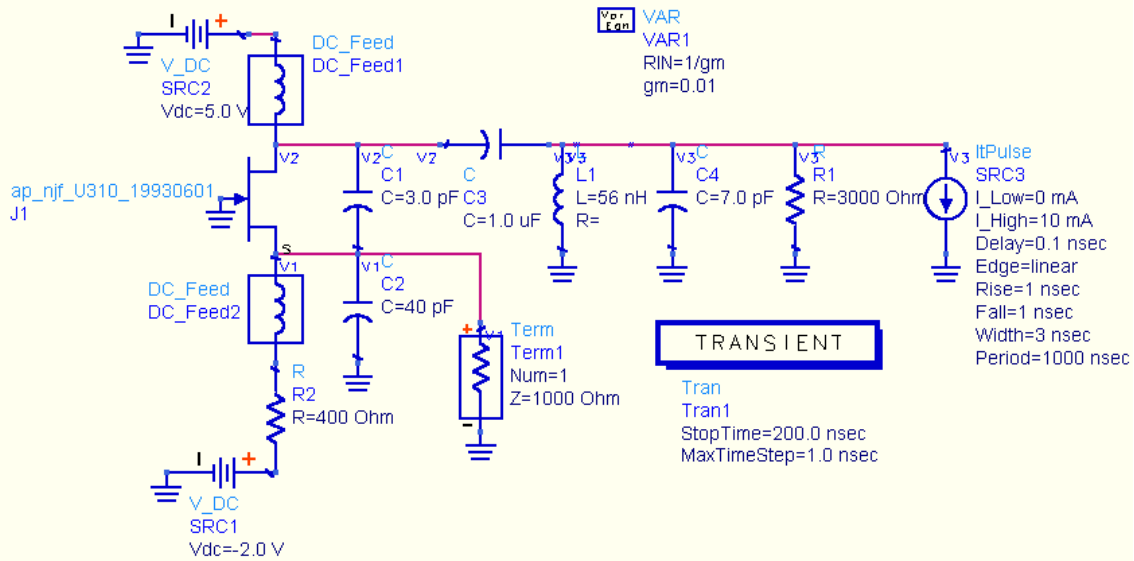

The same JFET Colpitts oscillator is now simulated in a closed loop condition using transient analysis. This uses a large signal device model and can predict compression and harmonic generation. Note the pulse current source. This is needed to start the oscillator because there will be no noise in the simulation that would jolt the circuit out of metastability. The current source is used here because it will give an infinite impedance after it delivers its current pulse and therefore will not load down the tank.

Transient analysis proceeds from an initial DC solution incrementally with small timesteps. A stop time is required to limit the length of the simulation. Sufficient time should be allowed for the simulation to reach a steady state condition. Large stop times generate large data files and require a lot of simulation time. V1 is shown below. Note that the oscillator is starting up and reaching what appears to be a steady state condition.

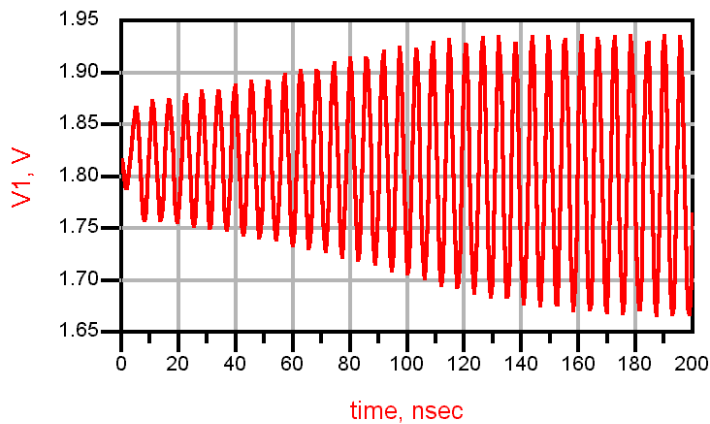

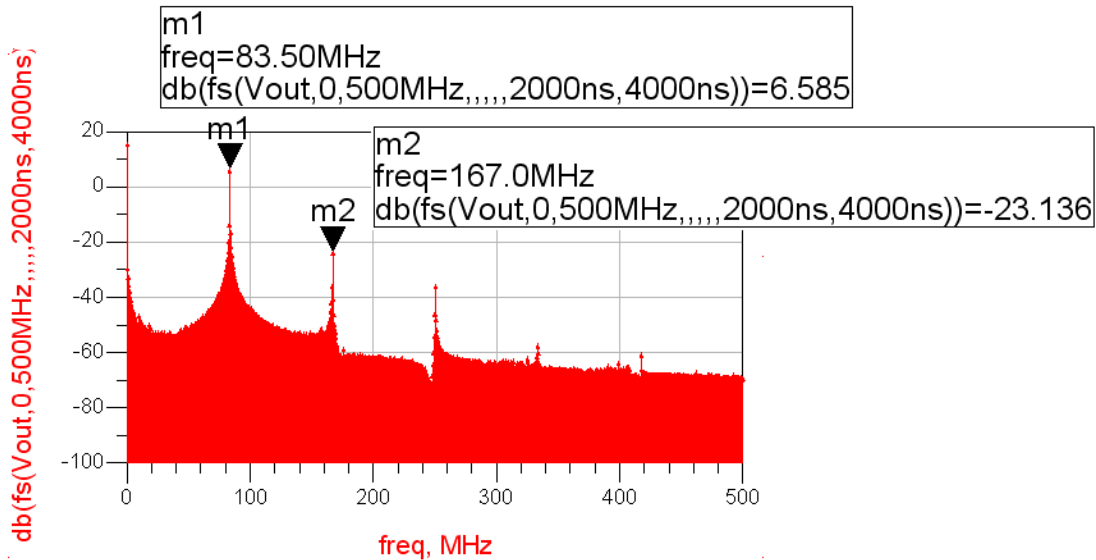

Output spectrum from a transient analysis simulation. The fft (fs function) is used to display frequency spectra. The format of the function is:

$$fs(Vout, \text{min. } f, \text{max } f, \text{,,,,,start time, stop time})$$

The start and stop times are intended to window out any initial startup transients so the spectral display will be more accurate. In this example, a 4 us simulation was run and the last 2 us were used to calculate the frequency spectrum. You need to add the 5 commas (count them) after max f to use this function.

The wide noise floor is an artifact of the fft conditions. The time domain waveform is resampled at equal time steps. The dynamic range of the simulation depends on the number of points used.

Below, the amplitude of V1 and V2 are compared. We can see that the average voltage at V2 is VDD, 5V. The peak voltage exceeds VDD. The device must be able to handle this peak voltage without breaking down.

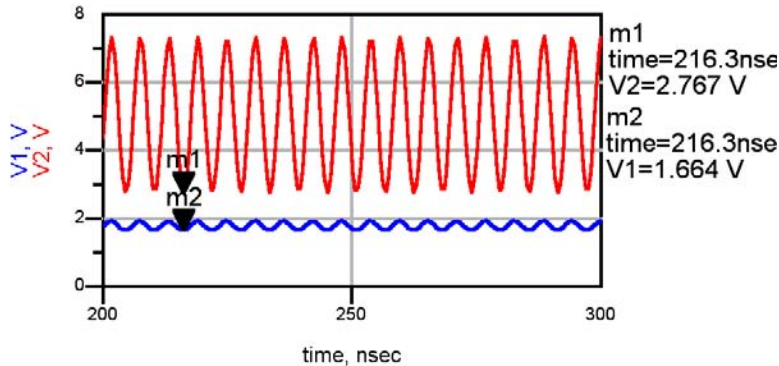

## Harmonic Balance Simulation

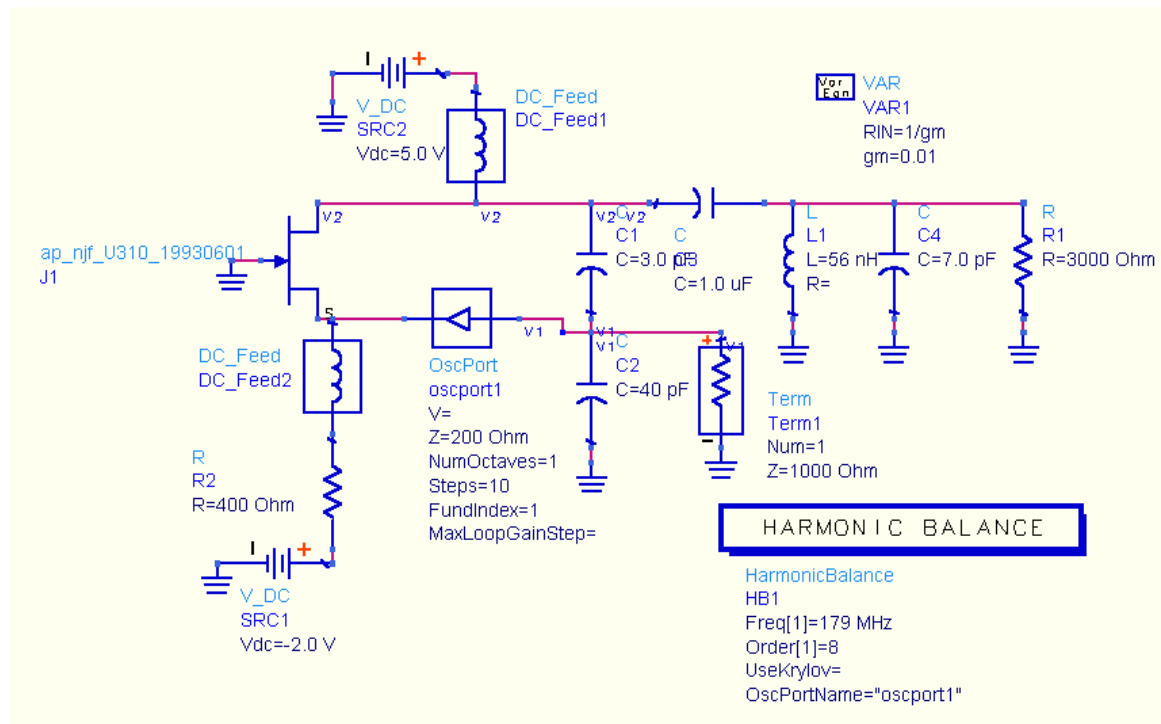

Harmonic balance simulation can also be used for closed-loop oscillator analysis. HB has the advantage that it calculates the steady-state solution directly and is relatively fast compared with transient analysis (when it converges). To simulate an oscillator, the ADS OscPort must be inserted into the signal path. The arrow must point in the right direction.

It is important to give HB a starting frequency that is close to what you expect to be the frequency of oscillation. Specify sufficient harmonics so that harmonic distortion can be calculated at the desired integer multiples of the fundamental frequency.

The harmonic balance controller must be activated for oscillator analysis in order to recognize the OscPort.

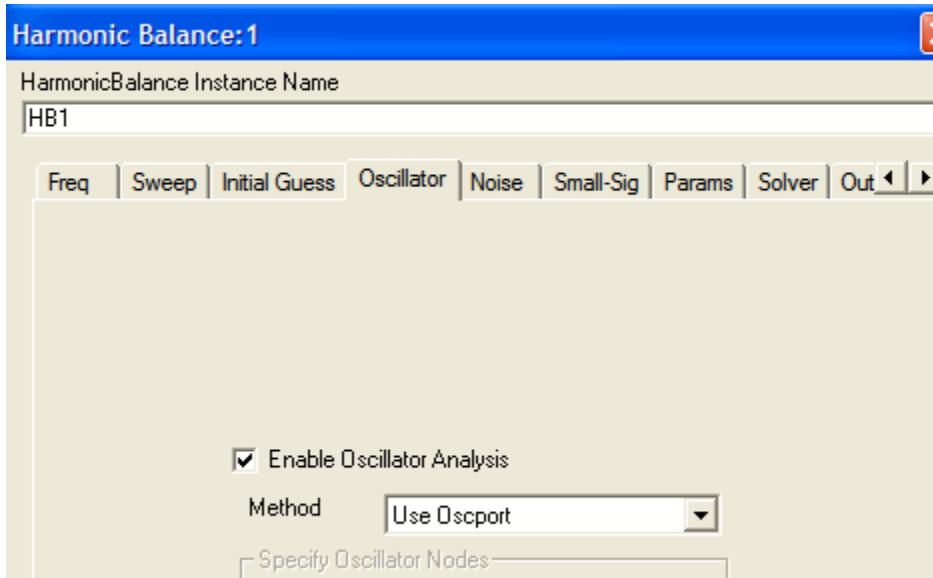

Information from the ADS help file on OscPort is included below, although its recommendations seldom help achieve convergence.

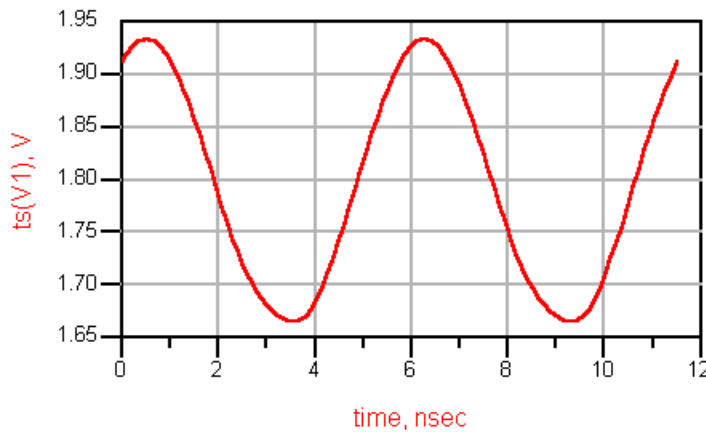
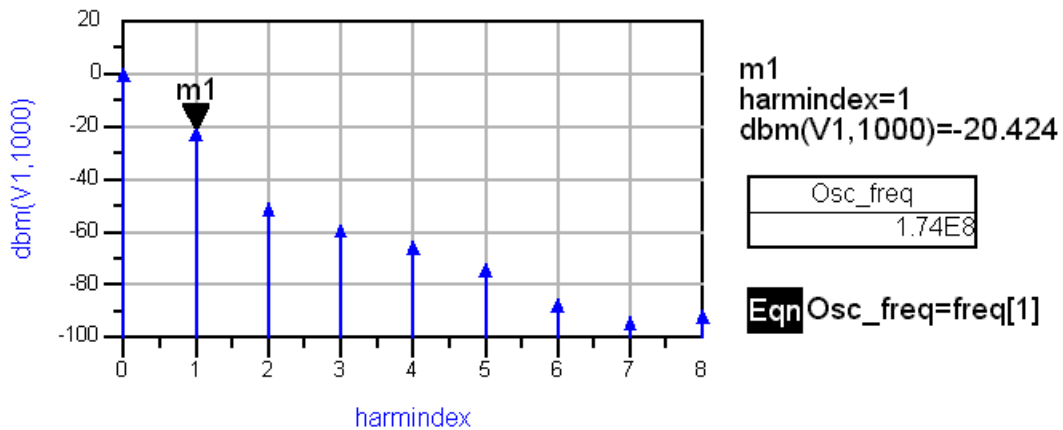

The output from a HB oscillator simulation can be either a frequency spectrum or a time domain representation of any voltage or current in the circuit. You can see that the

spectral representation is much cleaner than the FFT generated one from Transient simulation. This is because HB calculates only the harmonic frequencies.

The time domain is generated using the ts function. This is an inverse Fourier Transform or something similar that is used to convert the harmonic frequency amplitudes and phases into a time domain sequence.

## ***OscPort (Grounded Oscillator Port)***

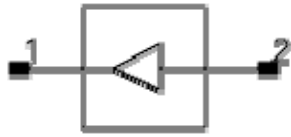

**Symbol**

**Available in**    **ADS and RFDE**

### **Parameters**

V = initial guess at fundamental voltage

Z = initial value for  $Z_0$ , in ohms (default: 1.1 ohms)

NumOctaves = number of octaves to search (default: 2)

Steps = number of steps per search octave (default: 10)

FundIndex = fundamental number for oscillator (default: 1)

Harm = harmonic or fundamental for oscillator (default: 1)

MaxLoopGainStep = maximum arc length continuation step size during loop-gain search

### **Notes/Equations**

1. This is a special device used for an oscillator analysis. Do not use more than one oscillator port in a circuit.
2. NumOctaves specifies the total number of octaves over which the oscillator search is done. Half of the octaves are below the initial frequency and half are above. For example, if NumOctaves is 2, then the frequency search goes from  $Freq/2$  to  $Freq \times 2$ . Steps sets the number of frequency points per octave that are used in the search. For a high-Q oscillator, a large number of steps might be required.
3. If fundamental voltage V is not specified, the simulator first performs a small-signal AC analysis to determine the actual frequency and oscillation voltage.

If V is specified, it represents an initial guess at the fundamental oscillator voltage at the point where the OscPort is inserted. The initial guess for V should be as close to the actual value as possible. An inaccurate value increases the simulation time and might prevent convergence. If it is not known, don't specify it.



4. Provided the circuit produces at least one complex conjugate pole pair in the right-half-plane over the frequency range tested, the analysis will determine the oscillation waveform and amplitude. Proper probe placement and impedance can reduce the analysis time significantly and help ensure accurate oscillator analysis results. To reduce the probability of a failed analysis, place the probe and set the initial impedance in a manner consistent with the following guidelines:

#### **Feedback Oscillators (such as Colpitts)**

- Insert probe at a point in the feedback loop where the signal is contained to a single path.
- Point the arrow of the probe in the direction of positive gain around the loop.
- Insert probe at a point in the feedback loop where source impedance is much smaller than load impedance (at least a factor of 10; a factor of 100 or more is preferable).
- Point the arrow of the probe at the high impedance (load) node.
- Set the initial probe impedance ( $Z_0$ ) to a value approximately half-way between the source and load impedances presented by the circuit at the point of insertion.

To minimize the analysis time, set the probe impedance to a factor of 10 below the load impedance, and a factor of 10 above the source impedance (provided the source and load impedances are sufficiently far apart). Doing this effectively reduces to zero the dependence of the small signal loop gain on  $Z_0$ .

#### **Negative Resistance Oscillators**

- Insert probe between a negative and positive impedance in the circuit. There should be no other signal paths between these two parts of the circuit. Typically, the probe is inserted between the resonator and the effective negative resistance.
- You can point the arrow of the probe at either the negative impedance node or the positive impedance node.
- Set the initial probe impedance to any reasonable value. To minimize the analysis time, it should be at least a factor of two higher or lower than the magnitude of the passive load impedance.

The frequency is specified on the harmonic balance analysis component. The value for  $Z$  is chosen based on impedance levels in the circuit and the degree of non-linearity in the circuit. Do not use either 1 or 0 for  $Z$  as this will cause convergence problems.

If the oscillator analysis fails, and this test indicates that the circuit should oscillate, the failure may be due to the fact that the circuit is too nonlinear. This problem can sometimes be solved by trying different impedance values of OscPort (determined by the  $Z$  attribute). Lower impedance values usually seem to work better. Also try reversing the OscPort direction.

Another approach is to try to get the oscillator to oscillate at some nicer parameter value and then to sweep the parameter value to the desired value. The parameter may be bias, self-bias impedance, some gain controlling value,

or another factor. In short, anything that will make the oscillator more linear, yet still let it oscillate.

FundIndex is used for selecting which fundamental tone is considered the unknown frequency during oscillator analysis.

The FundIndex default is 1, which means that Freq[1] on the Harmonic Balance controller is the unknown frequency. This should be changed only if a larger multi-tone system is simulated, such as an oscillator and mixer. In this case, the user may want Freq[1] to be a known driven source and Freq[2] to be the unknown frequency used by the oscillator; for this, set FundIndex=2. For the best harmonic balance solution, the frequency that causes the most nonlinearity should be Freq[1].

Harm is used to make a circuit oscillator on a harmonic of the fundamental frequency rather than directly on the fundamental. For example, the circuit may consist of a 2GHz oscillator followed by a divide-by-two circuit. In this case, the harmonic balance analysis would be set up with Freq[1]=1 GHz, and OscPort2 would have Harm=2. (Note that successful simulation of an oscillator and divider will most likely require that transient-assisted harmonic balance be used.)

Phase noise: Read T.Lee 18-1 to 18-3