



Intelli Sight

2019 Fall Quarter Design Review

IntelliSight Team

Vanessa Mejia

&

Xinyuan Zhang

Purpose

According to an October 2019 report by the World Health Organization (WHO), there are at least 2.2 billion people worldwide with vision impairment

Goal:

- By wearing IntelliSight sunglasses, visually impaired people can get the basic ability to identify their surrounding and no longer heavily rely on the help from others

Functionality - Modes

- Two modes
 - Single / double press button to switch mode
- Single press -> Camera Mode:
 - Capture a picture
- Double press -> Orientation Mode:
 - Double press button to activates / inactivate the mode
 - Nod twice to get the name of building they facing

Functionality - Orientation

- When user nodding, the IMU collect the data about the orientation
- MicroController receive data via I2C
- Application on the phone receives the data via bluetooth
- Analysis the building that user facing
- Sending results back to the headphone via bluetooth

Functionality - Camera

- single press button to take picture
- Microcontroller receive picture via SPI
- Application on the phone receives the data via bluetooth
- Recognizing objects in the image
- Sending results back to the headphone via bluetooth

Block Diagram

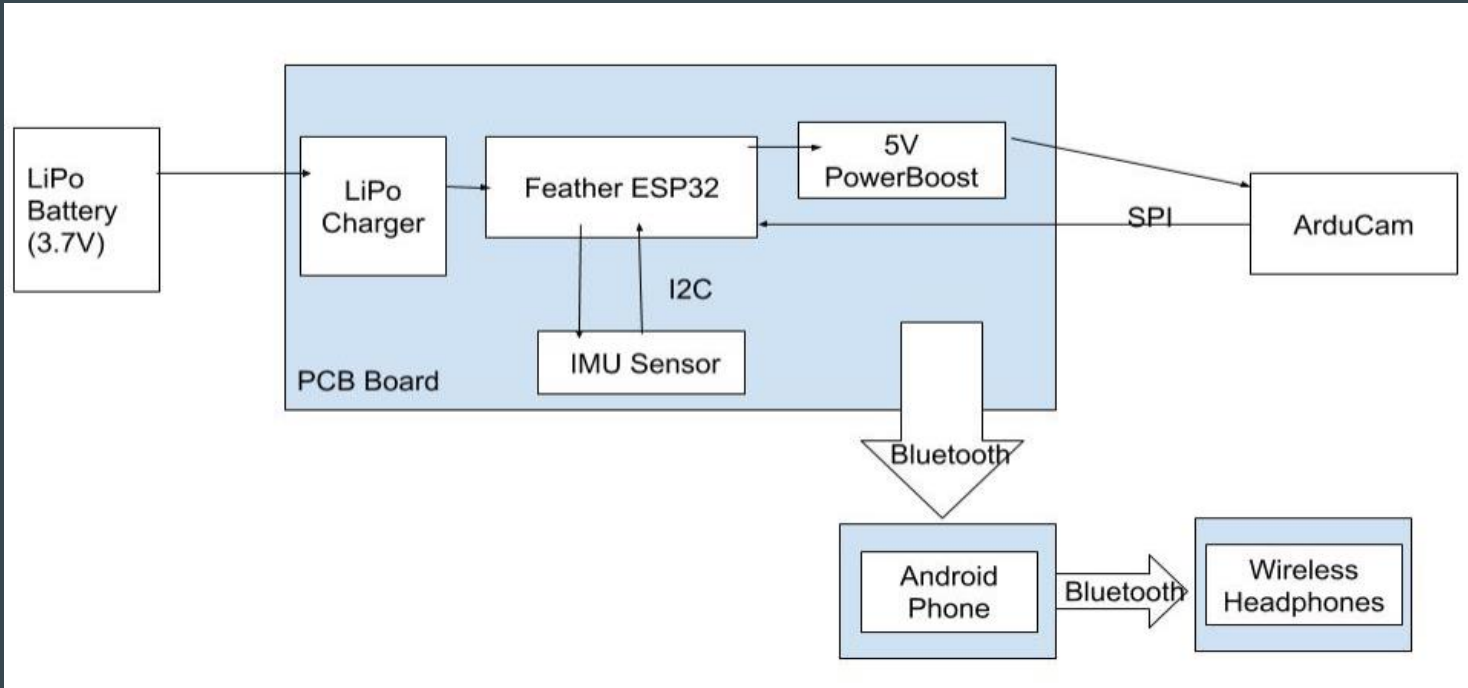

COMPONENTS

Power Support

Lithium-Ion Battery:

- Output Voltage: 3.7 V

USB LiPo Charger:

- Charge: 5 V
- Input : Mini-B usb, Barrel jack
- Output voltage: 3.7

PowerBoost: Adafruit MiniBoost

- Camera operates at 5V

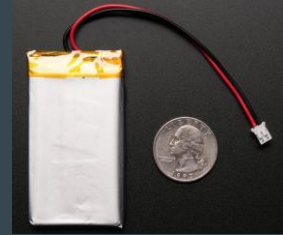

Microcontroller

ESP32 Feather Board:

- Operating voltage: 3.7 V
 - Powered by the LiPo battery
- Output voltage: 3.3 V with EN
- I2C → IMU
- SPI → Camera
- Bluetooth Module → Android phone



Data Collection

IMU: BNO055

- I2C
- Movement interrupt (INT)
- Operating Voltage: 3.3 V - 5V

ArduCam Mini 2MP Camera:

- SPI
- Active pixel size: 1600×1200
- Operating Voltage: 5 V, 70 mA



PCB Schematic

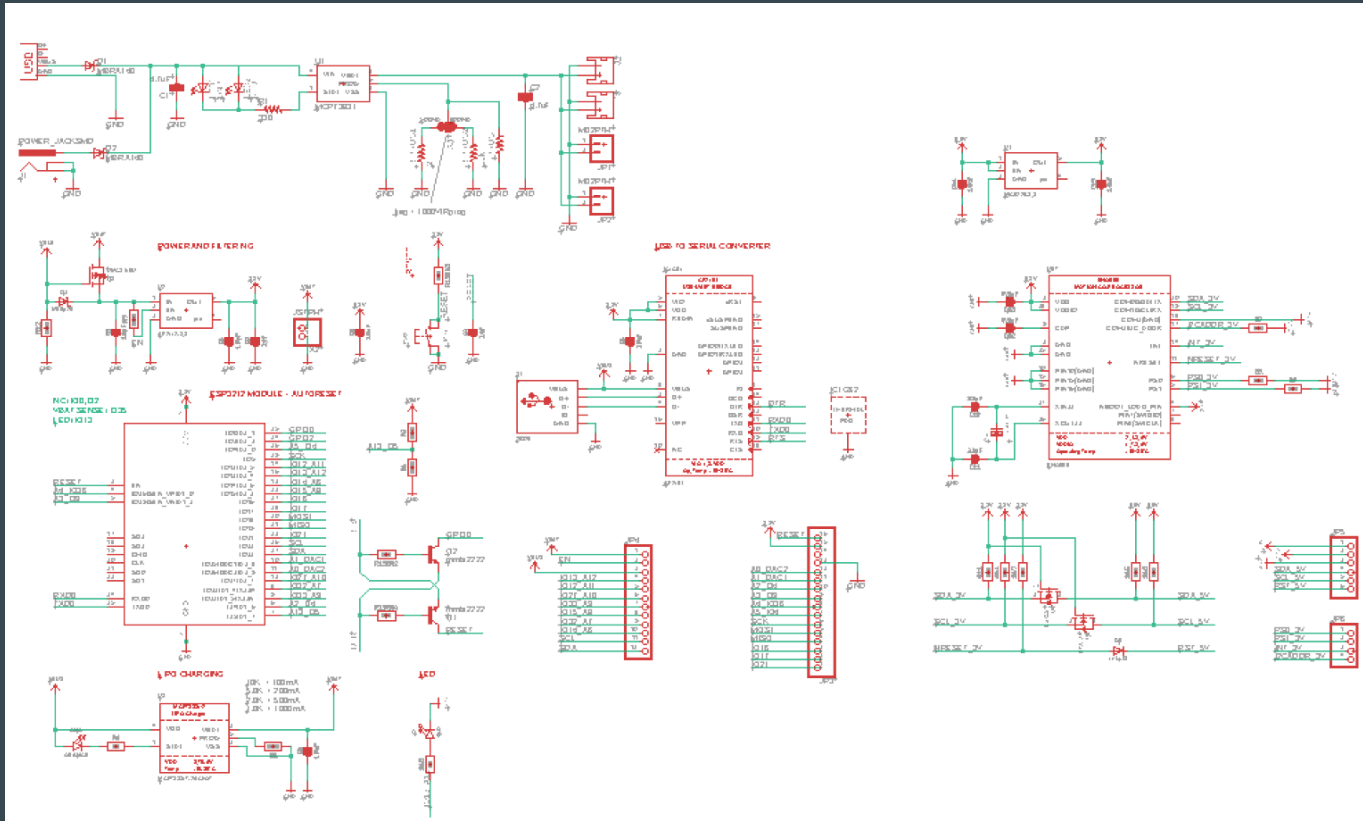

PCB Layout

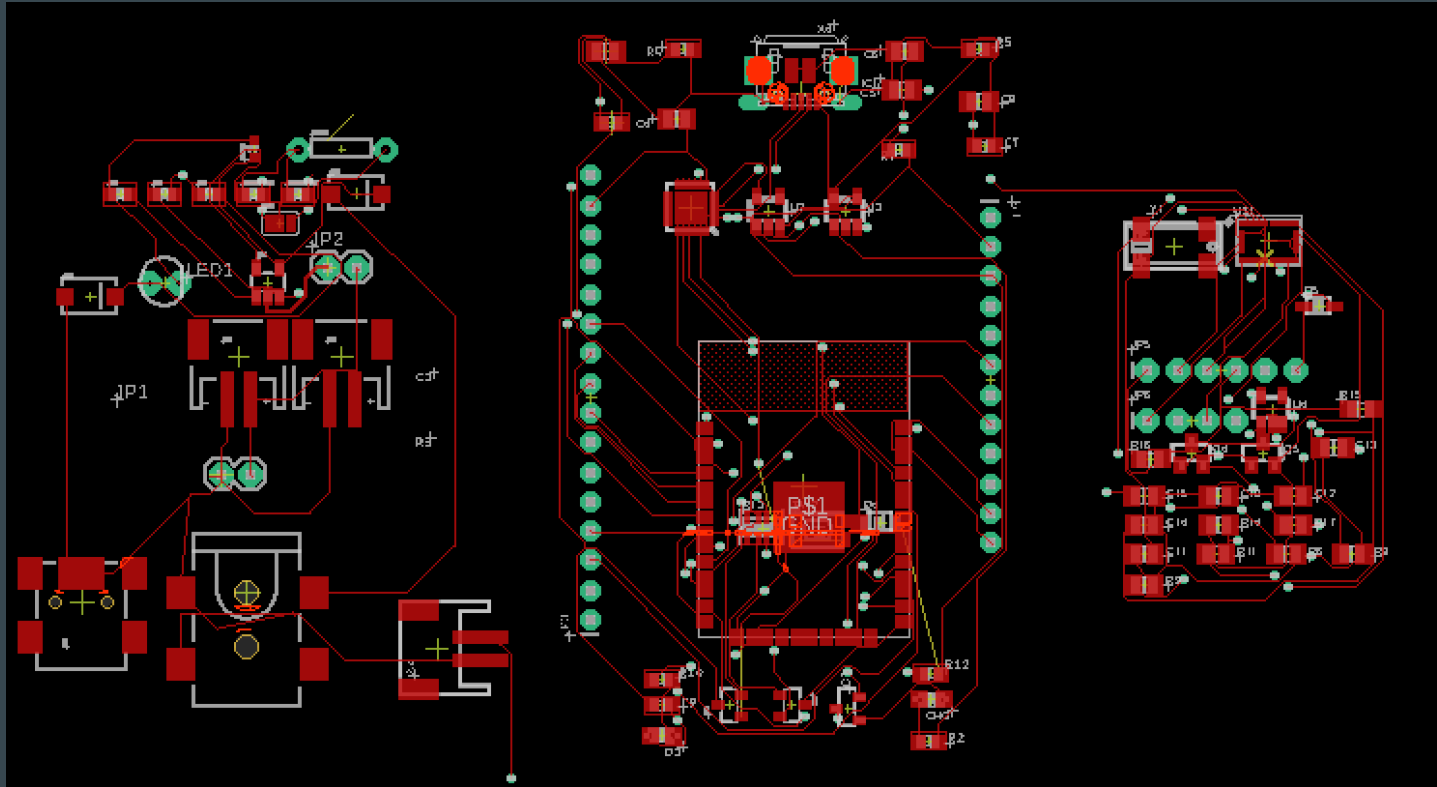

Software

Orientation mode:

- Receive data from IMU via bluetooth
 - Absolute orientation
 - Angular velocity vector
- Identify the building by using Geolocation API
- Send the name of the building to the wireless headphones

Capture mode:

- Receive captured picture via bluetooth
- Identify the objects in the picture using Cloud Vision API
- Send the information to the wireless headphones

Future Goals

End of Fall 2018:

- Have all the components working successfully with each other
- PCB Design - Work on removing the parts we are not directly using

Winter 2019 Goals:

- Develop android application on the phone
- PCB Board successfully working

A special thanks to:

Yogananda Isukapalli

Aditya Wadaskar

Kyle Douglas

Questions?